

IER TO	IE PRODUCT	USER SERVICE DEFINITION: OPERATIONAL CAPABILITY	TECHNICAL SERVICE LEVEL2	TECHNICAL SERVICE LEVEL 1
HN/ GO/ NGO/ IO	INFORMAL MESSAGE	INFORMAL MESSAGING	INFORMAL MESSAGING	CORE SERVICES
HN/ GO/ NGO/ IO	PORTAL SERVICES	PORTAL SERVICES	INFORMATION MANAGEMENT SERVICES	CORE ENTERPRISE SERVICES
HN/ GO/ NGO/ IO	VOICE (NON-SECURE)	VOICE	VOICE	CORE SERVICES
JHQ STATIC	FAX	FAX	FAX	CORE SERVICES
JHQ STATIC	FORMAL MESSAGE	FORMAL MESSAGING	FORMAL MESSAGING SERVICE	CORE ENTERPRISE SERVICES
JHQ STATIC	INFORMAL MESSAGE	INFORMAL MESSAGING	INFORMAL MESSAGING	CORE SERVICES
JHQ STATIC	VOICE (NON-SECURE)	VOICE	VOICE	CORE SERVICES
JHQ STATIC	VOICE (SECURE)	VOICE	VOICE	CORE SERVICES
JHQ STATIC	VTC	VTC	VTC	CORE SERVICES
JLSG	FAX	FAX	FAX	CORE SERVICES
JLSG	FORMAL MESSAGE	FORMAL MESSAGING	FORMAL MESSAGING SERVICE	CORE ENTERPRISE SERVICES
JLSG	INFORMAL MESSAGE	INFORMAL MESSAGING	INFORMAL MESSAGING	CORE SERVICES
JLSG	INSTANT MESSAGE	INSTANT MESSAGING	JOINT COI SERVICE	COI SERVICES
JLSG	MOVEMENTS AND TRANSPORTATION INFO	REPORTS	LOGISTICS COI SERVICE	COI SERVICES
JLSG	SUPPLIES AND MATERIAL	RESOURCE STATUS	LOGISTICS COI SERVICE	COI SERVICES
JLSG	VOICE (NON-SECURE)	VOICE	VOICE	CORE SERVICES
JLSG	VOICE (SECURE)	VOICE	VOICE	CORE SERVICES
JLSG	VTC	VTC	VTC	CORE SERVICES
JTF HQ	AOD	INTENT & GUIDANCE	AIR COI SERVICE	COI SERVICES
JTF HQ	TDL MESSAGES	SITUATIONAL AWARENESS	AIR COI SERVICE	COI SERVICES
JTF HQ	DIRECTORY SYNC	DIRECTORY SERVICES	DIRECTORY SERVICES	CORE SERVICES
JTF HQ	METEO INFO	METEO	ENVIRONMENTAL COI SERVICE	COI SERVICES
JTF HQ	FAX	FAX	FAX	CORE SERVICES
JTF HQ	FORMAL MESSAGE	FORMAL MESSAGING	FORMAL MESSAGING SERVICE	CORE ENTERPRISE SERVICES
JTF HQ	INFORMAL MESSAGE	INFORMAL MESSAGING	INFORMAL MESSAGING	CORE SERVICES
JTF HQ	PORTAL SERVICES	PORTAL SERVICES	INFORMATION MANAGEMENT SERVICES	CORE ENTERPRISE SERVICES
JTF HQ	IMAGERY	INTEL DATABASE SERVICES	JISR COI SERVICE	COI SERVICES
JTF HQ	MOTION IMAGERY	INTEL DATABASE SERVICES	JISR COI SERVICE	COI SERVICES
JTF HQ	BIOMETRIC INFO	REPORTS	JISR COI SERVICE	COI SERVICES
JTF HQ	EW INFO	REPORTS	JISR COI SERVICE	COI SERVICES
JTF HQ	HUMINT INFO	REPORTS	JISR COI SERVICE	COI SERVICES
JTF HQ	INTREPS	REPORTS	JISR COI SERVICE	COI SERVICES
JTF HQ	IR	REQUESTS AND RESPONSES	JISR COI SERVICE	COI SERVICES
JTF HQ	ISRR	REQUESTS AND RESPONSES	JISR COI SERVICE	COI SERVICES
JTF HQ	JISR COLLECTION INFO	REQUESTS AND RESPONSES	JISR COI SERVICE	COI SERVICES
JTF HQ	INSTANT MESSAGE	INSTANT MESSAGING	JOINT COI SERVICE	COI SERVICES
JTF HQ	JPITL	JOINT TARGETING	JOINT COI SERVICE	COI SERVICES
JTF HQ	JPTL	JOINT TARGETING	JOINT COI SERVICE	COI SERVICES
JTF HQ	NSL	JOINT TARGETING	JOINT COI SERVICE	COI SERVICES
JTF HQ	PTL	JOINT TARGETING	JOINT COI SERVICE	COI SERVICES
JTF HQ	TARGET FOLDER	JOINT TARGETING	JOINT COI SERVICE	COI SERVICES
JTF HQ	TNL	JOINT TARGETING	JOINT COI SERVICE	COI SERVICES
JTF HQ	OPLAN	PLANS	JOINT COI SERVICE	COI SERVICES
JTF HQ	INCREP	REPORTS	JOINT COI SERVICE	COI SERVICES
JTF HQ	FRAGO	TASKING & ORDERS	JOINT COI SERVICE	COI SERVICES
JTF HQ	JCO	TASKING & ORDERS	JOINT COI SERVICE	COI SERVICES
JTF HQ	TARGET INFORMATION (TST)	TIME SENSITIVE TARGETING	JOINT COI SERVICE	COI SERVICES
JTF HQ	TMD INFO	TMD INFO	MISSILE DEFENCE COI SERVICE	COI SERVICES
JTF HQ	OFFICE COLLABORATION (AUDIO)	COLLABORATION	UNIFIED COMM. & COLLAB SERVICES	CORE ENTERPRISE SERVICES
JTF HQ	OFFICE COLLABORATION (AV)	COLLABORATION	UNIFIED COMM. & COLLAB SERVICES	CORE ENTERPRISE SERVICES
JTF HQ	OFFICE COLLABORATION (CHAT)	COLLABORATION	UNIFIED COMM. & COLLAB SERVICES	CORE ENTERPRISE SERVICES
JTF HQ	OFFICE COLLABORATION (WHITEBOARD)	COLLABORATION	UNIFIED COMM. & COLLAB SERVICES	CORE ENTERPRISE SERVICES
JTF HQ	VOICE (NON-SECURE)	VOICE	VOICE	CORE SERVICES
JTF HQ	VOICE (SECURE)	VOICE	VOICE	CORE SERVICES
JTF HQ	VTC	VTC	VTC	CORE SERVICES
LCC	TDL MESSAGES	SITUATIONAL AWARENESS	AIR COI SERVICE	COI SERVICES
LCC	FAX	FAX	FAX	CORE SERVICES
LCC	FORMAL MESSAGE	FORMAL MESSAGING	FORMAL MESSAGING SERVICE	CORE ENTERPRISE SERVICES
LCC	INFORMAL MESSAGE	INFORMAL MESSAGING	INFORMAL MESSAGING	CORE SERVICES
LCC	PORTAL SERVICES	PORTAL SERVICES	INFORMATION MANAGEMENT SERVICES	CORE ENTERPRISE SERVICES

IER TO	IE PRODUCT	USER SERVICE DEFINITION: OPERATIONAL CAPABILITY	TECHNICAL SERVICE LEVEL2	TECHNICAL SERVICE LEVEL 1
LCC	FULL MOTION VIDEO	FULL MOTION VIDEO	JISR COI SERVICE	COI SERVICES
LCC	IMAGERY	INTEL DATABASE SERVICES	JISR COI SERVICE	COI SERVICES
LCC	MOTION IMAGERY	INTEL DATABASE SERVICES	JISR COI SERVICE	COI SERVICES
LCC	INSTANT MESSAGE	INSTANT MESSAGING	JOINT COI SERVICE	COI SERVICES
LCC	TARGET INFORMATION (TST)	TIME SENSITIVE TARGETING	JOINT COI SERVICE	COI SERVICES
LCC	OFFICE COLLABORATION (AUDIO)	COLLABORATION	UNIFIED COMM. & COLLAB SERVICES	CORE ENTERPRISE SERVICES
LCC	OFFICE COLLABORATION (AV)	COLLABORATION	UNIFIED COMM. & COLLAB SERVICES	CORE ENTERPRISE SERVICES
LCC	OFFICE COLLABORATION (CHAT)	COLLABORATION	UNIFIED COMM. & COLLAB SERVICES	CORE ENTERPRISE SERVICES
LCC	OFFICE COLLABORATION (WHITEBOARD)	COLLABORATION	UNIFIED COMM. & COLLAB SERVICES	CORE ENTERPRISE SERVICES
LCC	VOICE (NON-SECURE)	VOICE	VOICE	CORE SERVICES
LCC	VOICE (SECURE)	VOICE	VOICE	CORE SERVICES
LCC	VTC	VTC	VTC	CORE SERVICES
MCC	TDL MESSAGES	SITUATIONAL AWARENESS	AIR COI SERVICE	COI SERVICES
MCC	FAX	FAX	FAX	CORE SERVICES
MCC	FORMAL MESSAGE	FORMAL MESSAGING	FORMAL MESSAGING SERVICE	CORE ENTERPRISE SERVICES
MCC	INFORMAL MESSAGE	INFORMAL MESSAGING	INFORMAL MESSAGING	CORE SERVICES
MCC	PORTAL SERVICES	PORTAL SERVICES	INFORMATION MANAGEMENT SERVICES	CORE ENTERPRISE SERVICES
MCC	IMAGERY	INTEL DATABASE SERVICES	JISR COI SERVICE	COI SERVICES
MCC	MOTION IMAGERY	INTEL DATABASE SERVICES	JISR COI SERVICE	COI SERVICES
MCC	INSTANT MESSAGE	INSTANT MESSAGING	JOINT COI SERVICE	COI SERVICES
MCC	TARGET INFORMATION (TST)	TIME SENSITIVE TARGETING	JOINT COI SERVICE	COI SERVICES
MCC	OFFICE COLLABORATION (AUDIO)	COLLABORATION	UNIFIED COMM. & COLLAB SERVICES	CORE ENTERPRISE SERVICES
MCC	OFFICE COLLABORATION (AV)	COLLABORATION	UNIFIED COMM. & COLLAB SERVICES	CORE ENTERPRISE SERVICES
MCC	OFFICE COLLABORATION (CHAT)	COLLABORATION	UNIFIED COMM. & COLLAB SERVICES	CORE ENTERPRISE SERVICES
MCC	OFFICE COLLABORATION (WHITEBOARD)	COLLABORATION	UNIFIED COMM. & COLLAB SERVICES	CORE ENTERPRISE SERVICES
MCC	VOICE (NON-SECURE)	VOICE	VOICE	CORE SERVICES
MCC	VOICE (SECURE)	VOICE	VOICE	CORE SERVICES
MCC	VTC	VTC	VTC	CORE SERVICES
NAEW/DOB3	TDL MESSAGES	SITUATIONAL AWARENESS	AIR COI SERVICE	COI SERVICES
NAEW/DOB3	FAX	FAX	FAX	CORE SERVICES
NAEW/DOB3	FORMAL MESSAGE	FORMAL MESSAGING	FORMAL MESSAGING SERVICE	CORE ENTERPRISE SERVICES
NAEW/DOB3	INFORMAL MESSAGE	INFORMAL MESSAGING	INFORMAL MESSAGING	CORE SERVICES
NAEW/DOB3	PORTAL SERVICES	PORTAL SERVICES	INFORMATION MANAGEMENT SERVICES	CORE ENTERPRISE SERVICES
NAEW/DOB3	INSTANT MESSAGE	INSTANT MESSAGING	JOINT COI SERVICE	COI SERVICES
NAEW/DOB3	MOVEMENTS AND TRANSPORTATION INFO	REPORTS	LOGISTICS COI SERVICE	COI SERVICES
NAEW/DOB3	SUPPLIES AND MATERIAL	RESOURCE STATUS	LOGISTICS COI SERVICE	COI SERVICES
NAEW/DOB3	OFFICE COLLABORATION (AUDIO)	COLLABORATION	UNIFIED COMM. & COLLAB SERVICES	CORE ENTERPRISE SERVICES
NAEW/DOB3	OFFICE COLLABORATION (AV)	COLLABORATION	UNIFIED COMM. & COLLAB SERVICES	CORE ENTERPRISE SERVICES
NAEW/DOB3	OFFICE COLLABORATION (CHAT)	COLLABORATION	UNIFIED COMM. & COLLAB SERVICES	CORE ENTERPRISE SERVICES
NAEW/DOB3	OFFICE COLLABORATION (WHITEBOARD)	COLLABORATION	UNIFIED COMM. & COLLAB SERVICES	CORE ENTERPRISE SERVICES
NAEW/DOB3	VOICE (NON-SECURE)	VOICE	VOICE	CORE SERVICES
NAEW/DOB3	VOICE (SECURE)	VOICE	VOICE	CORE SERVICES
NAEW/DOB3	VTC	VTC	VTC	CORE SERVICES
PODS/DOBS	TDL MESSAGES	SITUATIONAL AWARENESS	AIR COI SERVICE	COI SERVICES
PODS/DOBS	FAX	FAX	FAX	CORE SERVICES
PODS/DOBS	INFORMAL MESSAGE	INFORMAL MESSAGING	INFORMAL MESSAGING	CORE SERVICES
PODS/DOBS	PORTAL SERVICES	PORTAL SERVICES	INFORMATION MANAGEMENT SERVICES	CORE ENTERPRISE SERVICES
PODS/DOBS	INSTANT MESSAGE	INSTANT MESSAGING	JOINT COI SERVICE	COI SERVICES
PODS/DOBS	VOICE (NON-SECURE)	VOICE	VOICE	CORE SERVICES
PODS/DOBS	VOICE (SECURE)	VOICE	VOICE	CORE SERVICES
SOCC	TDL MESSAGES	SITUATIONAL AWARENESS	AIR COI SERVICE	COI SERVICES
SOCC	FAX	FAX	FAX	CORE SERVICES
SOCC	FORMAL MESSAGE	FORMAL MESSAGING	FORMAL MESSAGING SERVICE	CORE ENTERPRISE SERVICES
SOCC	INFORMAL MESSAGE	INFORMAL MESSAGING	INFORMAL MESSAGING	CORE SERVICES
SOCC	PORTAL SERVICES	PORTAL SERVICES	INFORMATION MANAGEMENT SERVICES	CORE ENTERPRISE SERVICES
SOCC	FULL MOTION VIDEO	FULL MOTION VIDEO	JISR COI SERVICE	COI SERVICES
SOCC	IMAGERY	INTEL DATABASE SERVICES	JISR COI SERVICE	COI SERVICES
SOCC	MOTION IMAGERY	INTEL DATABASE SERVICES	JISR COI SERVICE	COI SERVICES
SOCC	INSTANT MESSAGE	INSTANT MESSAGING	JOINT COI SERVICE	COI SERVICES
SOCC	TARGET INFORMATION (TST)	TIME SENSITIVE TARGETING	JOINT COI SERVICE	COI SERVICES
SOCC	OFFICE COLLABORATION (AUDIO)	COLLABORATION	UNIFIED COMM. & COLLAB SERVICES	CORE ENTERPRISE SERVICES
SOCC	OFFICE COLLABORATION (AV)	COLLABORATION	UNIFIED COMM. & COLLAB SERVICES	CORE ENTERPRISE SERVICES
SOCC	OFFICE COLLABORATION (CHAT)	COLLABORATION	UNIFIED COMM. & COLLAB SERVICES	CORE ENTERPRISE SERVICES
SOCC	OFFICE COLLABORATION (WHITEBOARD)	COLLABORATION	UNIFIED COMM. & COLLAB SERVICES	CORE ENTERPRISE SERVICES
SOCC	VOICE (NON-SECURE)	VOICE	VOICE	CORE SERVICES
SOCC	VOICE (SECURE)	VOICE	VOICE	CORE SERVICES
SOCC	VTC	VTC	VTC	CORE SERVICES

Table D-II-4-2: JFAC/AOC Uni-directional Information Products Disseminated

IER TO	IE PRODUCT	USER SERVICE DEFINITION: OPERATIONAL CAPABILITY	TECHNICAL SERVICE LEVEL2	TECHNICAL SERVICE LEVEL 1
CBRN	RAP	SITUATIONAL AWARENESS	AIR COI SERVICE	COI SERVICES
CBRN	TMD INFO	TMD INFO	MISSILE DEFENCE COI SERVICE	COI SERVICES
DARS	AOD	INTENT & GUIDANCE	AIR COI SERVICE	COI SERVICES
DARS	ACP	PLANS	AIR COI SERVICE	COI SERVICES
DARS	ACO	TASKING & ORDERS	AIR COI SERVICE	COI SERVICES
DARS	ATO (ADATP3 F058)	TASKING & ORDERS	AIR COI SERVICE	COI SERVICES
DARS	ATO (ADATP3 F068)	TASKING & ORDERS	AIR COI SERVICE	COI SERVICES
DARS	OPTASKLINK	TASKING & ORDERS	AIR COI SERVICE	COI SERVICES
DARS	METEO INFO	METEO	ENVIRONMENTAL COI SERVICE	COI SERVICES
DARS	CONTAMINATION REPORTS	NBC	ENVIRONMENTAL COI SERVICE	COI SERVICES
DARS	REP	SITUATIONAL AWARENESS	ENVIRONMENTAL COI SERVICE	COI SERVICES
DARS	GEO INFORMATION	GEO SERVICES	GEOSPATIAL SERVICES	CORE ENTERPRISE SERVICES
DARS	INTSUM	REPORTS	JISR COI SERVICE	COI SERVICES
DARS	JPITL	JOINT TARGETING	JOINT COI SERVICE	COI SERVICES
DARS	JPTL	JOINT TARGETING	JOINT COI SERVICE	COI SERVICES
DARS	OPLAN	PLANS	JOINT COI SERVICE	COI SERVICES
DARS	TMD INFO	TMD INFO	MISSILE DEFENCE COI SERVICE	COI SERVICES
DOB1/APOD	AOD	INTENT & GUIDANCE	AIR COI SERVICE	COI SERVICES
DOB1/APOD	ACP	PLANS	AIR COI SERVICE	COI SERVICES
DOB1/APOD	RAP	SITUATIONAL AWARENESS	AIR COI SERVICE	COI SERVICES
DOB1/APOD	ACO	TASKING & ORDERS	AIR COI SERVICE	COI SERVICES
DOB1/APOD	ATO (ADATP3 F058)	TASKING & ORDERS	AIR COI SERVICE	COI SERVICES
DOB1/APOD	ATO (ADATP3 F068)	TASKING & ORDERS	AIR COI SERVICE	COI SERVICES
DOB1/APOD	OPTASKLINK	TASKING & ORDERS	AIR COI SERVICE	COI SERVICES
DOB1/APOD	METEO INFO	METEO	ENVIRONMENTAL COI SERVICE	COI SERVICES
DOB1/APOD	REP	SITUATIONAL AWARENESS	ENVIRONMENTAL COI SERVICE	COI SERVICES
DOB1/APOD	OPLAN	PLANS	JOINT COI SERVICE	COI SERVICES
DOB1/APOD	TMD INFO	TMD INFO	MISSILE DEFENCE COI SERVICE	COI SERVICES
HN/ GO/ NGO/ IO	ASM OVERLAY	SITUATIONAL AWARENESS	AIR COI SERVICE	COI SERVICES
HN/ GO/ NGO/ IO	FLIGHT PLANS	SITUATIONAL AWARENESS	CIMIC COI SERVICE	COI SERVICES
HN/ GO/ NGO/ IO	MILITARY FLIGHT SCHEDULE	SITUATIONAL AWARENESS	CIMIC COI SERVICE	COI SERVICES
JLSG	LOGASSESSREP	REPORTS	LOGISTICS COI SERVICE	COI SERVICES
JLSG	TMD INFO	TMD INFO	MISSILE DEFENCE COI SERVICE	COI SERVICES
JTF HQ	ACP	PLANS	AIR COI SERVICE	COI SERVICES
JTF HQ	SITREP	REPORTS	AIR COI SERVICE	COI SERVICES
JTF HQ	RAP	SITUATIONAL AWARENESS	AIR COI SERVICE	COI SERVICES
JTF HQ	ACO	TASKING & ORDERS	AIR COI SERVICE	COI SERVICES
JTF HQ	ATO (ADATP3 F058)	TASKING & ORDERS	AIR COI SERVICE	COI SERVICES
JTF HQ	ATO (ADATP3 F068)	TASKING & ORDERS	AIR COI SERVICE	COI SERVICES
JTF HQ	OPTASKLINK	TASKING & ORDERS	AIR COI SERVICE	COI SERVICES
JTF HQ	FULL MOTION VIDEO	FULL MOTION VIDEO	JISR COI SERVICE	COI SERVICES
JTF HQ	INCREP	REPORTS	JOINT COI SERVICE	COI SERVICES
JTF HQ	CIS SITREP	REPORTS	JOINT NOC SERVICES	SMC
JTF HQ	MEDSITREP	MEDICAL	LOGISTICS COI SERVICE	COI SERVICES

IER TO	IE PRODUCT	USER SERVICE DEFINITION: OPERATIONAL CAPABILITY	TECHNICAL SERVICE LEVEL2	TECHNICAL SERVICE LEVEL 1
LCC	AOD	INTENT & GUIDANCE	AIR COI SERVICE	COI SERVICES
LCC	ACP	PLANS	AIR COI SERVICE	COI SERVICES
LCC	RESPONSE	REQUESTS AND RESPONSES	AIR COI SERVICE	COI SERVICES
LCC	RAP	SITUATIONAL AWARENESS	AIR COI SERVICE	COI SERVICES
LCC	ACO	TASKING & ORDERS	AIR COI SERVICE	COI SERVICES
LCC	ATO (ADATP3 F058)	TASKING & ORDERS	AIR COI SERVICE	COI SERVICES
LCC	ATO (ADATP3 F068)	TASKING & ORDERS	AIR COI SERVICE	COI SERVICES
LCC	OPTASKLINK	TASKING & ORDERS	AIR COI SERVICE	COI SERVICES
LCC	TMD INFO	TMD INFO	MISSILE DEFENCE COI SERVICE	COI SERVICES
MCC	AOD	INTENT & GUIDANCE	AIR COI SERVICE	COI SERVICES
MCC	ACP	PLANS	AIR COI SERVICE	COI SERVICES
MCC	RESPONSE	REQUESTS AND RESPONSES	AIR COI SERVICE	COI SERVICES
MCC	RAP	SITUATIONAL AWARENESS	AIR COI SERVICE	COI SERVICES
MCC	ACO	TASKING & ORDERS	AIR COI SERVICE	COI SERVICES
MCC	ATO (ADATP3 F058)	TASKING & ORDERS	AIR COI SERVICE	COI SERVICES
MCC	ATO (ADATP3 F068)	TASKING & ORDERS	AIR COI SERVICE	COI SERVICES
MCC	OPTASKLINK	TASKING & ORDERS	AIR COI SERVICE	COI SERVICES
MCC	TMD INFO	TMD INFO	MISSILE DEFENCE COI SERVICE	COI SERVICES
NAEW/DOB3	AOD	INTENT & GUIDANCE	AIR COI SERVICE	COI SERVICES
NAEW/DOB3	ACP	PLANS	AIR COI SERVICE	COI SERVICES
NAEW/DOB3	RAP	SITUATIONAL AWARENESS	AIR COI SERVICE	COI SERVICES
NAEW/DOB3	ACO	TASKING & ORDERS	AIR COI SERVICE	COI SERVICES
NAEW/DOB3	ATO (ADATP3 F058)	TASKING & ORDERS	AIR COI SERVICE	COI SERVICES
NAEW/DOB3	ATO (ADATP3 F068)	TASKING & ORDERS	AIR COI SERVICE	COI SERVICES
NAEW/DOB3	OPTASKLINK	TASKING & ORDERS	AIR COI SERVICE	COI SERVICES
NAEW/DOB3	METEO INFO	METEO	ENVIRONMENTAL COI SERVICE	COI SERVICES
NAEW/DOB3	PORTAL SERVICES	PORTAL SERVICES	INFORMATION MANAGEMENT SERVICES	CORE ENTERPRISE SERVICES
PODS/DOBS	PORTAL SERVICES	PORTAL SERVICES	INFORMATION MANAGEMENT SERVICES	CORE ENTERPRISE SERVICES
PODS/DOBS	TMD INFO	TMD INFO	MISSILE DEFENCE COI SERVICE	COI SERVICES
SOCC	AOD	INTENT & GUIDANCE	AIR COI SERVICE	COI SERVICES
SOCC	RESPONSE	REQUESTS AND RESPONSES	AIR COI SERVICE	COI SERVICES
SOCC	RAP	SITUATIONAL AWARENESS	AIR COI SERVICE	COI SERVICES
SOCC	ACO	TASKING & ORDERS	AIR COI SERVICE	COI SERVICES
SOCC	ATO (ADATP3 F058)	TASKING & ORDERS	AIR COI SERVICE	COI SERVICES
SOCC	ATO (ADATP3 F068)	TASKING & ORDERS	AIR COI SERVICE	COI SERVICES
SOCC	OPTASKLINK	TASKING & ORDERS	AIR COI SERVICE	COI SERVICES
SOCC	TMD INFO	TMD INFO	MISSILE DEFENCE COI SERVICE	COI SERVICES

Table D-II-4-3: JFAC/AOC Uni-directional Information Products Consumed

IER FROM	IE PRODUCT	USER SERVICE DEFINITION: OPERATIONAL CAPABILITY	TECHNICAL SERVICE LEVEL2	TECHNICAL SERVICE LEVEL 1
DARS	RAP	SITUATIONAL AWARENESS	AIR COI SERVICE	COI SERVICES
DARS	CIS SITREP	REPORTS	JOINT NOC SERVICES	SMC
DARS	MEDSITREP	MEDICAL	LOGISTICS COI SERVICE	COI SERVICES
DARS	LOGASSESSREP	REPORTS	LOGISTICS COI SERVICE	COI SERVICES
JLSG	RLP	SITUATIONAL AWARENESS	LOGISTICS COI SERVICE	COI SERVICES
JTF HQ	GEO INFORMATION	GEO SERVICES	GEOSPATIAL SERVICES	CORE ENTERPRISE SERVICES
JTF HQ	DOCUMENT COLLABORATION & STORAGE	INFORMATION MGT	INFORMATION MANAGEMENT SERVICES	CORE ENTERPRISE SERVICES
JTF HQ	BICES INFO	BICES INFO	JISR COI SERVICE	COI SERVICES
JTF HQ	IMINT REP	REPORTS	JISR COI SERVICE	COI SERVICES
JTF HQ	INTSUM	REPORTS	JISR COI SERVICE	COI SERVICES
JTF HQ	JPDAL	PLANS	JOINT COI SERVICE	COI SERVICES
JTF HQ	COP	SITUATIONAL AWARENESS	JOINT COI SERVICE	COI SERVICES
JTF HQ	CIS PICTURE	SITUATIONAL AWARENESS	JOINT NOC SERVICES	SMC
JTF HQ	FFT INFO	FFT	SITUATIONAL AWARENESS SERVICE	COI SERVICES
LCC	ACMREQ	REQUESTS AND RESPONSES	AIR COI SERVICE	COI SERVICES
LCC	AIRSUPREQ	REQUESTS AND RESPONSES	AIR COI SERVICE	COI SERVICES
LCC	ORBAT	INTENT & GUIDANCE	JOINT COI SERVICE	COI SERVICES
LCC	ENSITREP	REPORTS	LAND COI SERVICE	COI SERVICES
LCC	OWNSITREP	REPORTS	LAND COI SERVICE	COI SERVICES
LCC	RGP	SITUATIONAL AWARENESS	LAND COI SERVICE	COI SERVICES
LCC	FFT INFO	FFT	SITUATIONAL AWARENESS SERVICE	COI SERVICES
MCC	ACMREQ	REQUESTS AND RESPONSES	AIR COI SERVICE	COI SERVICES
MCC	AIRSUPREQ	REQUESTS AND RESPONSES	AIR COI SERVICE	COI SERVICES
SOCC	ACMREQ	REQUESTS AND RESPONSES	AIR COI SERVICE	COI SERVICES
SOCC	AIRSUPREQ	REQUESTS AND RESPONSES	AIR COI SERVICE	COI SERVICES

D-II-5 Information Exchange Requirements SOCC.

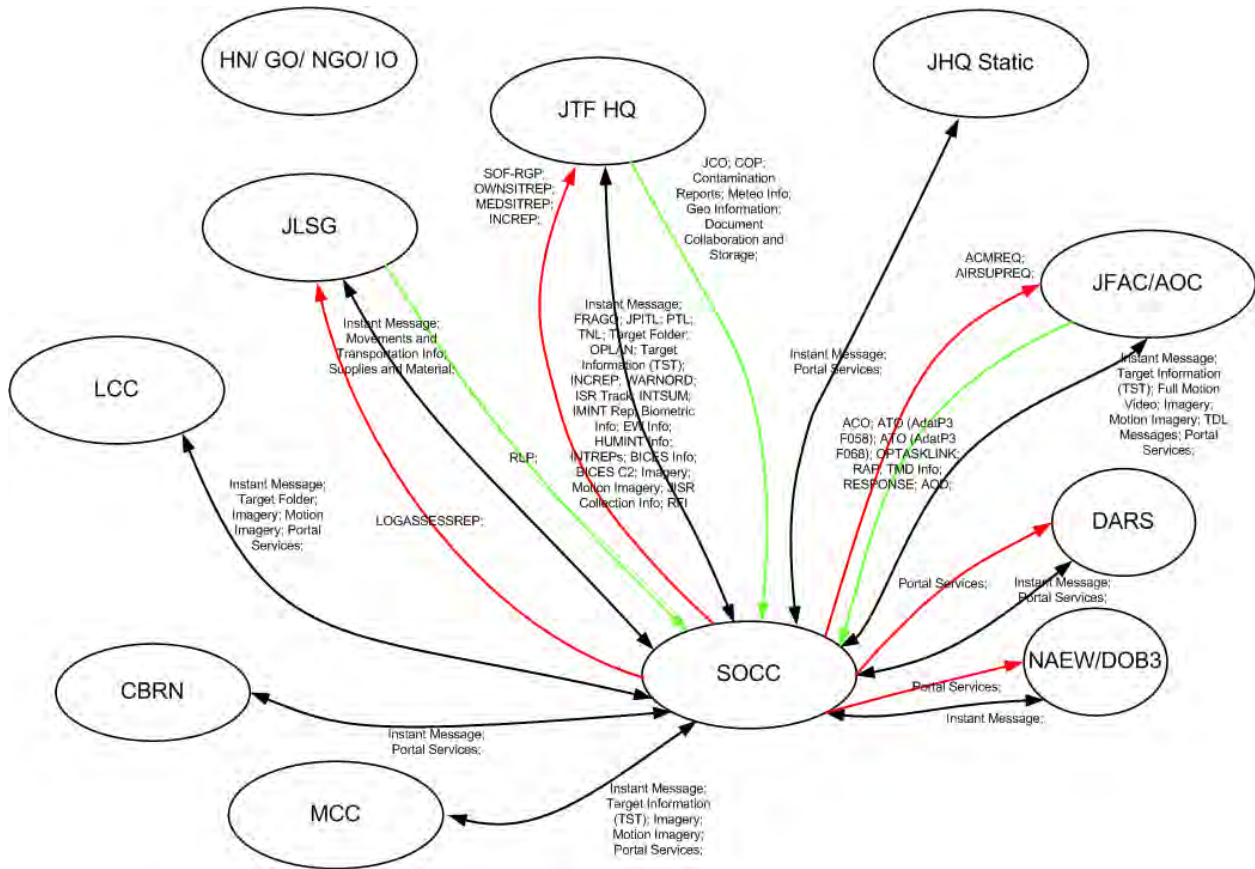

Figure D-II-5-1: C2 Information Product Exchange SOCC

Specific C2 information product exchange for the SOCC is depicted in Figure D-II-5-1. The bi-directional black arrow represents bi-directional exchange of information products, further detailed in Table D-II-5-1. The unidirectional red arrow shows information products sent from the SOCC to other C2 entities, further detailed in Table D-II-5-2. Finally, the green unidirectional arrows represent information products sent to and consumed by the SOCC. These product exchanges are further detailed in Table D-II-5-3.

The bi-directional Information Exchange Requirements between the SOCC and the other relevant C2 entities, as introduced in Figure D-1-1 and D-II-5-1 are depicted in Table D-II-5-1. The column “IERs To” lists the C2 entity the information products are exchanged with (in both directions), the second column lists the product that is exchanged. The operational capability the product supports is given in column 3, while columns 4 and 5 provide the technical services at Level 2 and Level 1.

The information products disseminated from the SOCC to the other relevant C2 entities, as introduced in Figure D-II-5-1, are depicted in Table D-II-5-2.

Finally, Table D-II-5-3 contains the unidirectional information products consumed by the SOCC, as introduced in Figure D-II-5-1.

Table D-II-5-1: SOCC Bi-directional IERs

IER TO	IE PRODUCT	USER SERVICE DEFINITION: OPERATIONAL CAPABILITY	TECHNICAL SERVICE LEVEL2	TECHNICAL SERVICE LEVEL 1
JFAC/AOC	TDL MESSAGES	SITUATIONAL AWARENESS	AIR COI SERVICE	COI SERVICES
JFAC/AOC	FAX	FAX	FAX	CORE SERVICES
JFAC/AOC	FORMAL MESSAGE	FORMAL MESSAGING	FORMAL MESSAGING SERVICE	CORE ENTERPRISE SERVICES
JFAC/AOC	INFORMAL MESSAGE	INFORMAL MESSAGING	INFORMAL MESSAGING	CORE SERVICES
JFAC/AOC	PORTAL SERVICES	PORTAL SERVICES	INFORMATION MANAGEMENT SERVICES	CORE ENTERPRISE SERVICES
JFAC/AOC	FULL MOTION VIDEO	FULL MOTION VIDEO	JISR COI SERVICE	COI SERVICES
JFAC/AOC	IMAGERY	INTEL DATABASE SERVICES	JISR COI SERVICE	COI SERVICES
JFAC/AOC	MOTION IMAGERY	INTEL DATABASE SERVICES	JISR COI SERVICE	COI SERVICES
JFAC/AOC	INSTANT MESSAGE	INSTANT MESSAGING	JOINT COI SERVICE	COI SERVICES
JFAC/AOC	TARGET INFORMATION (TST)	TIME SENSITIVE TARGETING	JOINT COI SERVICE	COI SERVICES
JFAC/AOC	OFFICE COLLABORATION (AUDIO)	COLLABORATION	UNIFIED COMM. & COLLAB SERVICES	CORE ENTERPRISE SERVICES
JFAC/AOC	OFFICE COLLABORATION (AV)	COLLABORATION	UNIFIED COMM. & COLLAB SERVICES	CORE ENTERPRISE SERVICES
JFAC/AOC	OFFICE COLLABORATION (CHAT)	COLLABORATION	UNIFIED COMM. & COLLAB SERVICES	CORE ENTERPRISE SERVICES
JFAC/AOC	OFFICE COLLABORATION (WHITEBOARD)	COLLABORATION	UNIFIED COMM. & COLLAB SERVICES	CORE ENTERPRISE SERVICES
JFAC/AOC	VOICE (NON-SECURE)	VOICE	VOICE	CORE SERVICES
JFAC/AOC	VOICE (SECURE)	VOICE	VOICE	CORE SERVICES
JFAC/AOC	VTC	VTC	VTC	CORE SERVICES
CBRN	FAX	FAX	FAX	CORE SERVICES
CBRN	FORMAL MESSAGE	FORMAL MESSAGING	FORMAL MESSAGING SERVICE	CORE ENTERPRISE SERVICES
CBRN	INFORMAL MESSAGE	INFORMAL MESSAGING	INFORMAL MESSAGING	CORE SERVICES
CBRN	PORTAL SERVICES	PORTAL SERVICES	INFORMATION MANAGEMENT SERVICES	CORE ENTERPRISE SERVICES
CBRN	INSTANT MESSAGE	INSTANT MESSAGING	JOINT COI SERVICE	COI SERVICES
CBRN	OFFICE COLLABORATION (AUDIO)	COLLABORATION	UNIFIED COMM. & COLLAB SERVICES	CORE ENTERPRISE SERVICES
CBRN	OFFICE COLLABORATION (AV)	COLLABORATION	UNIFIED COMM. & COLLAB SERVICES	CORE ENTERPRISE SERVICES
CBRN	OFFICE COLLABORATION (CHAT)	COLLABORATION	UNIFIED COMM. & COLLAB SERVICES	CORE ENTERPRISE SERVICES
CBRN	OFFICE COLLABORATION (WHITEBOARD)	COLLABORATION	UNIFIED COMM. & COLLAB SERVICES	CORE ENTERPRISE SERVICES
CBRN	VOICE (NON-SECURE)	VOICE	VOICE	CORE SERVICES
CBRN	VOICE (SECURE)	VOICE	VOICE	CORE SERVICES
CBRN	VTC	VTC	VTC	CORE SERVICES
DARS	FAX	FAX	FAX	CORE SERVICES
DARS	FORMAL MESSAGE	FORMAL MESSAGING	FORMAL MESSAGING SERVICE	CORE ENTERPRISE SERVICES
DARS	INFORMAL MESSAGE	INFORMAL MESSAGING	INFORMAL MESSAGING	CORE SERVICES
DARS	PORTAL SERVICES	PORTAL SERVICES	INFORMATION MANAGEMENT SERVICES	CORE ENTERPRISE SERVICES
DARS	INSTANT MESSAGE	INSTANT MESSAGING	JOINT COI SERVICE	COI SERVICES
DARS	VOICE (NON-SECURE)	VOICE	VOICE	CORE SERVICES
DARS	VOICE (SECURE)	VOICE	VOICE	CORE SERVICES
DARS	VTC	VTC	VTC	CORE SERVICES
DOB1/APOD	FAX	FAX	FAX	CORE SERVICES
DOB1/APOD	INFORMAL MESSAGE	INFORMAL MESSAGING	INFORMAL MESSAGING	CORE SERVICES
DOB1/APOD	VOICE (NON-SECURE)	VOICE	VOICE	CORE SERVICES
DOB1/APOD	VOICE (SECURE)	VOICE	VOICE	CORE SERVICES
HN/ GO/ NGO/ IO	FAX	FAX	FAX	CORE SERVICES
HN/ GO/ NGO/ IO	INFORMAL MESSAGE	INFORMAL MESSAGING	INFORMAL MESSAGING	CORE SERVICES
HN/ GO/ NGO/ IO	VOICE (NON-SECURE)	VOICE	VOICE	CORE SERVICES
JHQ STATIC	FAX	FAX	FAX	CORE SERVICES
JHQ STATIC	FORMAL MESSAGE	FORMAL MESSAGING	FORMAL MESSAGING SERVICE	CORE ENTERPRISE SERVICES
JHQ STATIC	INFORMAL MESSAGE	INFORMAL MESSAGING	INFORMAL MESSAGING	CORE SERVICES
JHQ STATIC	PORTAL SERVICES	PORTAL SERVICES	INFORMATION MANAGEMENT SERVICES	CORE ENTERPRISE SERVICES
JHQ STATIC	INSTANT MESSAGE	INSTANT MESSAGING	JOINT COI SERVICE	COI SERVICES
JHQ STATIC	VOICE (NON-SECURE)	VOICE	VOICE	CORE SERVICES
JHQ STATIC	VOICE (SECURE)	VOICE	VOICE	CORE SERVICES
JHQ STATIC	VTC	VTC	VTC	CORE SERVICES
JLSG	FAX	FAX	FAX	CORE SERVICES
JLSG	FORMAL MESSAGE	FORMAL MESSAGING	FORMAL MESSAGING SERVICE	CORE ENTERPRISE SERVICES
JLSG	INFORMAL MESSAGE	INFORMAL MESSAGING	INFORMAL MESSAGING	CORE SERVICES

IER TO	IE PRODUCT	USER SERVICE DEFINITION: OPERATIONAL CAPABILITY	TECHNICAL SERVICE LEVEL2	TECHNICAL SERVICE LEVEL 1
JLSG	INSTANT MESSAGE	INSTANT MESSAGING	JOINT COI SERVICE	COI SERVICES
JLSG	MOVEMENTS AND TRANSPORTATION INFO	REPORTS	LOGISTICS COI SERVICE	COI SERVICES
JLSG	SUPPLIES AND MATERIAL	RESOURCE STATUS	LOGISTICS COI SERVICE	COI SERVICES
JLSG	VOICE (NON-SECURE)	VOICE	VOICE	CORE SERVICES
JLSG	VOICE (SECURE)	VOICE	VOICE	CORE SERVICES
JLSG	VTC	VTC	VTC	CORE SERVICES
JTF HQ	DIRECTORY SYNC	DIRECTORY SERVICES	DIRECTORY SERVICES	CORE SERVICES
JTF HQ	FAX	FAX	FAX	CORE SERVICES
JTF HQ	FORMAL MESSAGE	FORMAL MESSAGING	FORMAL MESSAGING SERVICE	CORE ENTERPRISE SERVICES
JTF HQ	INFORMAL MESSAGE	INFORMAL MESSAGING	INFORMAL MESSAGING	CORE SERVICES
JTF HQ	PORTAL SERVICES	PORTAL SERVICES	INFORMATION MANAGEMENT SERVICES	CORE ENTERPRISE SERVICES
JTF HQ	BICES C2	BICES C2	JISR COI SERVICE	COI SERVICES
JTF HQ	BICES INFO	BICES INFO	JISR COI SERVICE	COI SERVICES
JTF HQ	IMAGERY	INTEL DATABASE SERVICES	JISR COI SERVICE	COI SERVICES
JTF HQ	MOTION IMAGERY	INTEL DATABASE SERVICES	JISR COI SERVICE	COI SERVICES
JTF HQ	BIOMETRIC INFO	REPORTS	JISR COI SERVICE	COI SERVICES
JTF HQ	EW INFO	REPORTS	JISR COI SERVICE	COI SERVICES
JTF HQ	HUMINT INFO	REPORTS	JISR COI SERVICE	COI SERVICES
JTF HQ	IMINT REP	REPORTS	JISR COI SERVICE	COI SERVICES
JTF HQ	INTREPS	REPORTS	JISR COI SERVICE	COI SERVICES
JTF HQ	INTSUM	REPORTS	JISR COI SERVICE	COI SERVICES
JTF HQ	JISR COLLECTION INFO	REQUESTS AND RESPONSES	JISR COI SERVICE	COI SERVICES
JTF HQ	RFI	REQUESTS AND RESPONSES	JISR COI SERVICE	COI SERVICES
JTF HQ	SIGINT CO-ORD	REQUESTS AND RESPONSES	JISR COI SERVICE	COI SERVICES
JTF HQ	ISR TRACK	SITUATIONAL AWARENESS	JISR COI SERVICE	COI SERVICES
JTF HQ	INSTANT MESSAGE	INSTANT MESSAGING	JOINT COI SERVICE	COI SERVICES
JTF HQ	JPITL	JOINT TARGETING	JOINT COI SERVICE	COI SERVICES
JTF HQ	PTL	JOINT TARGETING	JOINT COI SERVICE	COI SERVICES
JTF HQ	TARGET FOLDER	JOINT TARGETING	JOINT COI SERVICE	COI SERVICES
JTF HQ	TNL	JOINT TARGETING	JOINT COI SERVICE	COI SERVICES
JTF HQ	OPLAN	PLANS	JOINT COI SERVICE	COI SERVICES
JTF HQ	INCREP	REPORTS	JOINT COI SERVICE	COI SERVICES
JTF HQ	FRAGO	TASKING & ORDERS	JOINT COI SERVICE	COI SERVICES
JTF HQ	TARGET INFORMATION (TST)	TIME SENSITIVE TARGETING	JOINT COI SERVICE	COI SERVICES
JTF HQ	FFT INFO	FFT	SITUATIONAL AWARENESS SERVICE	COI SERVICES
JTF HQ	OFFICE COLLABORATION (AUDIO)	COLLABORATION	UNIFIED COMM. & COLLAB SERVICES	CORE ENTERPRISE SERVICES
JTF HQ	OFFICE COLLABORATION (AV)	COLLABORATION	UNIFIED COMM. & COLLAB SERVICES	CORE ENTERPRISE SERVICES
JTF HQ	OFFICE COLLABORATION (CHAT)	COLLABORATION	UNIFIED COMM. & COLLAB SERVICES	CORE ENTERPRISE SERVICES
JTF HQ	OFFICE COLLABORATION (WHITEBOARD)	COLLABORATION	UNIFIED COMM. & COLLAB SERVICES	CORE ENTERPRISE SERVICES
JTF HQ	VOICE (NON-SECURE)	VOICE	VOICE	CORE SERVICES
JTF HQ	VOICE (SECURE)	VOICE	VOICE	CORE SERVICES
JTF HQ	VTC	VTC	VTC	CORE SERVICES
LCC	FAX	FAX	FAX	CORE SERVICES
LCC	FORMAL MESSAGE	FORMAL MESSAGING	FORMAL MESSAGING SERVICE	CORE ENTERPRISE SERVICES
LCC	INFORMAL MESSAGE	INFORMAL MESSAGING	INFORMAL MESSAGING	CORE SERVICES
LCC	PORTAL SERVICES	PORTAL SERVICES	INFORMATION MANAGEMENT SERVICES	CORE ENTERPRISE SERVICES
LCC	IMAGERY	INTEL DATABASE SERVICES	JISR COI SERVICE	COI SERVICES
LCC	MOTION IMAGERY	INTEL DATABASE SERVICES	JISR COI SERVICE	COI SERVICES
LCC	INSTANT MESSAGE	INSTANT MESSAGING	JOINT COI SERVICE	COI SERVICES
LCC	TARGET FOLDER	JOINT TARGETING	JOINT COI SERVICE	COI SERVICES
LCC	OFFICE COLLABORATION (AUDIO)	COLLABORATION	UNIFIED COMM. & COLLAB SERVICES	CORE ENTERPRISE SERVICES
LCC	OFFICE COLLABORATION (AV)	COLLABORATION	UNIFIED COMM. & COLLAB SERVICES	CORE ENTERPRISE SERVICES
LCC	OFFICE COLLABORATION (CHAT)	COLLABORATION	UNIFIED COMM. & COLLAB SERVICES	CORE ENTERPRISE SERVICES
LCC	OFFICE COLLABORATION (WHITEBOARD)	COLLABORATION	UNIFIED COMM. & COLLAB SERVICES	CORE ENTERPRISE SERVICES
LCC	VOICE (NON-SECURE)	VOICE	VOICE	CORE SERVICES
LCC	VOICE (SECURE)	VOICE	VOICE	CORE SERVICES
LCC	VTC	VTC	VTC	CORE SERVICES
MCC	FAX	FAX	FAX	CORE SERVICES
MCC	FORMAL MESSAGE	FORMAL MESSAGING	FORMAL MESSAGING SERVICE	CORE ENTERPRISE SERVICES
MCC	INFORMAL MESSAGE	INFORMAL MESSAGING	INFORMAL MESSAGING	CORE SERVICES

IER TO	IE PRODUCT	USER SERVICE DEFINITION: OPERATIONAL CAPABILITY	TECHNICAL SERVICE LEVEL2	TECHNICAL SERVICE LEVEL 1
MCC	PORTAL SERVICES	PORTAL SERVICES	INFORMATION MANAGEMENT SERVICES	CORE ENTERPRISE SERVICES
MCC	IMAGERY	INTEL DATABASE SERVICES	JISR COI SERVICE	COI SERVICES
MCC	MOTION IMAGERY	INTEL DATABASE SERVICES	JISR COI SERVICE	COI SERVICES
MCC	INSTANT MESSAGE	INSTANT MESSAGING	JOINT COI SERVICE	COI SERVICES
MCC	TARGET INFORMATION (TST)	TIME SENSITIVE TARGETING	JOINT COI SERVICE	COI SERVICES
MCC	OFFICE COLLABORATION (AUDIO)	COLLABORATION	UNIFIED COMM. & COLLAB SERVICES	CORE ENTERPRISE SERVICES
MCC	OFFICE COLLABORATION (AV)	COLLABORATION	UNIFIED COMM. & COLLAB SERVICES	CORE ENTERPRISE SERVICES
MCC	OFFICE COLLABORATION (CHAT)	COLLABORATION	UNIFIED COMM. & COLLAB SERVICES	CORE ENTERPRISE SERVICES
MCC	OFFICE COLLABORATION (WHITEBOARD)	COLLABORATION	UNIFIED COMM. & COLLAB SERVICES	CORE ENTERPRISE SERVICES
MCC	VOICE (NON-SECURE)	VOICE	VOICE	CORE SERVICES
MCC	VOICE (SECURE)	VOICE	VOICE	CORE SERVICES
MCC	VTC	VTC	VTC	CORE SERVICES
NAEW/DOB3	FAX	FAX	FAX	CORE SERVICES
NAEW/DOB3	FORMAL MESSAGE	FORMAL MESSAGING	FORMAL MESSAGING SERVICE	CORE ENTERPRISE SERVICES
NAEW/DOB3	INFORMAL MESSAGE	INFORMAL MESSAGING	INFORMAL MESSAGING	CORE SERVICES
NAEW/DOB3	INSTANT MESSAGE	INSTANT MESSAGING	JOINT COI SERVICE	COI SERVICES
NAEW/DOB3	VOICE (NON-SECURE)	VOICE	VOICE	CORE SERVICES
NAEW/DOB3	VOICE (SECURE)	VOICE	VOICE	CORE SERVICES
PODS/DOBS	FAX	FAX	FAX	CORE SERVICES
PODS/DOBS	INFORMAL MESSAGE	INFORMAL MESSAGING	INFORMAL MESSAGING	CORE SERVICES
PODS/DOBS	VOICE (NON-SECURE)	VOICE	VOICE	CORE SERVICES
PODS/DOBS	VOICE (SECURE)	VOICE	VOICE	CORE SERVICES

Table D-II-5-2: SOCC Uni-directional Information Products Disseminated

IER TO	IE PRODUCT	USER SERVICE DEFINITION: OPERATIONAL CAPABILITY	TECHNICAL SERVICE LEVEL2	TECHNICAL SERVICE LEVEL 1
JFAC/AOC	ACMREQ	REQUESTS AND RESPONSES	AIR COI SERVICE	COI SERVICES
JFAC/AOC	AIRSUPREQ	REQUESTS AND RESPONSES	AIR COI SERVICE	COI SERVICES
DARS	PORTAL SERVICES	PORTAL SERVICES	INFORMATION MANAGEMENT SERVICES	CORE ENTERPRISE SERVICES
JLSG	LOGASSESSREP	REPORTS	LOGISTICS COI SERVICE	COI SERVICES
JTF HQ	INCREP	REPORTS	JOINT COI SERVICE	COI SERVICES
JTF HQ	CIS SITREP	REPORTS	JOINT NOC SERVICES	SMC
JTF HQ	OWNSITREP	REPORTS	LAND COI SERVICE	COI SERVICES
JTF HQ	MEDSITREP	MEDICAL	LOGISTICS COI SERVICE	COI SERVICES
JTF HQ	SOF-RGP	SITUATIONAL AWARENESS	SPECIAL OPERATIONS COI SERVICE	COI SERVICES
NAEW/DOB3	PORTAL SERVICES	PORTAL SERVICES	INFORMATION MANAGEMENT SERVICES	CORE ENTERPRISE SERVICES
PODS/DOBS	PORTAL SERVICES	PORTAL SERVICES	INFORMATION MANAGEMENT SERVICES	CORE ENTERPRISE SERVICES

Table D-II-5-3: SOCC Uni-directional Information Products Consumed

IER FROM	IE PRODUCT	USER SERVICE DEFINITION: OPERATIONAL CAPABILITY	TECHNICAL SERVICE LEVEL2	TECHNICAL SERVICE LEVEL 1
JFAC/AOC	AOD	INTENT & GUIDANCE	AIR COI SERVICE	COI SERVICES
JFAC/AOC	RESPONSE	REQUESTS AND RESPONSES	AIR COI SERVICE	COI SERVICES
JFAC/AOC	RAP	SITUATIONAL AWARENESS	AIR COI SERVICE	COI SERVICES
JFAC/AOC	ACO	TASKING & ORDERS	AIR COI SERVICE	COI SERVICES
JFAC/AOC	ATO (ADATP3 F058)	TASKING & ORDERS	AIR COI SERVICE	COI SERVICES
JFAC/AOC	ATO (ADATP3 F068)	TASKING & ORDERS	AIR COI SERVICE	COI SERVICES
JFAC/AOC	OPTASKLINK	TASKING & ORDERS	AIR COI SERVICE	COI SERVICES
JFAC/AOC	TMD INFO	TMD INFO	MISSILE DEFENCE COI SERVICE	COI SERVICES
JLSG	RLP	SITUATIONAL AWARENESS	LOGISTICS COI SERVICE	COI SERVICES
JTF HQ	METEO INFO	METEO	ENVIRONMENTAL COI SERVICE	COI SERVICES
JTF HQ	CONTAMINATION REPORTS	NBC	ENVIRONMENTAL COI SERVICE	COI SERVICES
JTF HQ	GEO INFORMATION	GEO SERVICES	GEOSPATIAL SERVICES	CORE ENTERPRISE SERVICES
JTF HQ	DOCUMENT COLLABORATION & STORAGE	INFORMATION MGT	INFORMATION MANAGEMENT SERVICES	CORE ENTERPRISE SERVICES
JTF HQ	COP	SITUATIONAL AWARENESS	JOINT COI SERVICE	COI SERVICES
JTF HQ	JCO	TASKING & ORDERS	JOINT COI SERVICE	COI SERVICES
JTF HQ	CIS PICTURE	SITUATIONAL AWARENESS	JOINT NOC SERVICES	SMC

D-II -6 Information Exchange Requirements JLSG.

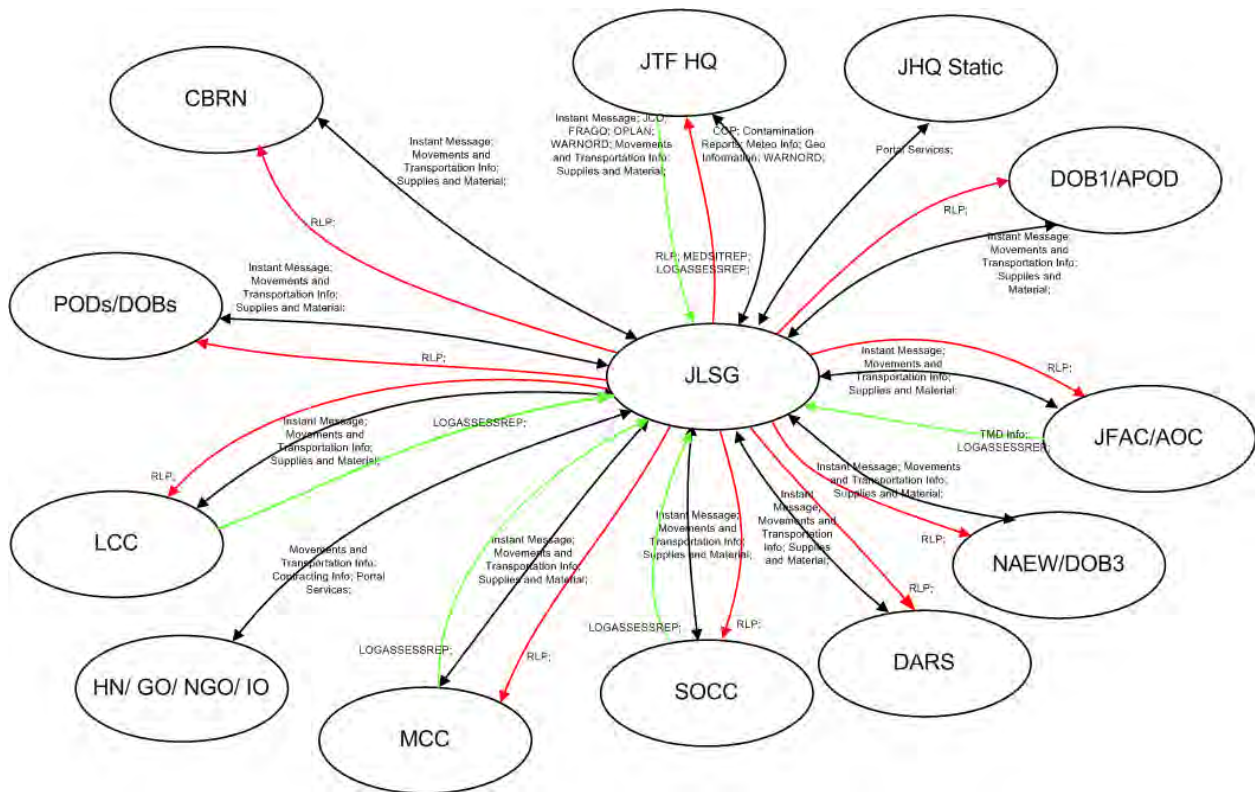

Figure D-II-6-1: C2 Information Product Exchange JLSG

Specific C2 information product exchange for the JLSG is depicted in Figure D-II-6-1. The bi-directional black arrow represents bi-directional exchange of information products, further detailed in Table D-II-6-1. The unidirectional red arrow shows information products sent from the JLSG to other C2 entities, further detailed in Table D-II-6-2. Finally, the green unidirectional arrows represent information products sent to and consumed by the JLSG. These product exchanges are further detailed in Table D-II-6-3.

The bi-directional Information Exchange Requirements between the JLSG and the other relevant C2 entities, as introduced in Figure D-1-1 and D-II-6-1 are depicted in Table D-II-6-1. The column “IERs To” lists the C2 entity the information products are exchanged with (in both directions), the second column lists the product that is exchanged. The operational capability the product supports is given in column 3, while columns 4 and 5 provide the technical services at Level 2 and Level 1.

The information products disseminated from the JLSG to the other relevant C2 entities, as introduced in Figure D-II-6-1, are depicted in Table D-II-6-2.

Finally, Table D-II-6-3 contains the unidirectional information products consumed by the JLSG, as introduced in Figure D-II-6-1.

Table D-II-6-1: JLSG Bi-directional IERs

IER TO	IE PRODUCT	USER SERVICE DEFINITION: OPERATIONAL CAPABILITY	TECHNICAL SERVICE LEVEL 2	TECHNICAL SERVICE LEVEL 1
JFAC/AOC	FAX	FAX	FAX	CORE SERVICES
JFAC/AOC	FORMAL MESSAGE	FORMAL MESSAGING	FORMAL MESSAGING SERVICE	CORE ENTERPRISE SERVICES
JFAC/AOC	INFORMAL MESSAGE	INFORMAL MESSAGING	INFORMAL MESSAGING	CORE SERVICES
JFAC/AOC	INSTANT MESSAGE	INSTANT MESSAGING	JOINT COI SERVICE	COI SERVICES
JFAC/AOC	MOVEMENTS AND TRANSPORTATION INFO	REPORTS	LOGISTICS COI SERVICE	COI SERVICES
JFAC/AOC	SUPPLIES AND MATERIAL	RESOURCE STATUS	LOGISTICS COI SERVICE	COI SERVICES
JFAC/AOC	VOICE (NON-SECURE)	VOICE	VOICE	CORE SERVICES
JFAC/AOC	VOICE (SECURE)	VOICE	VOICE	CORE SERVICES
JFAC/AOC	VTC	VTC	VTC	CORE SERVICES
BDE	FAX	FAX	FAX	CORE SERVICES
BDE	VOICE (NON-SECURE)	VOICE	VOICE	CORE SERVICES
BDE	VOICE (SECURE)	VOICE	VOICE	CORE SERVICES
CBRN	FAX	FAX	FAX	CORE SERVICES
CBRN	FORMAL MESSAGE	FORMAL MESSAGING	FORMAL MESSAGING SERVICE	CORE ENTERPRISE SERVICES
CBRN	INFORMAL MESSAGE	INFORMAL MESSAGING	INFORMAL MESSAGING	CORE SERVICES
CBRN	INSTANT MESSAGE	INSTANT MESSAGING	JOINT COI SERVICE	COI SERVICES
CBRN	MOVEMENTS AND TRANSPORTATION INFO	REPORTS	LOGISTICS COI SERVICE	COI SERVICES
CBRN	SUPPLIES AND MATERIAL	RESOURCE STATUS	LOGISTICS COI SERVICE	COI SERVICES
CBRN	VOICE (NON-SECURE)	VOICE	VOICE	CORE SERVICES
CBRN	VOICE (SECURE)	VOICE	VOICE	CORE SERVICES
CBRN	VTC	VTC	VTC	CORE SERVICES
DARS	FAX	FAX	FAX	CORE SERVICES
DARS	FORMAL MESSAGE	FORMAL MESSAGING	FORMAL MESSAGING SERVICE	CORE ENTERPRISE SERVICES
DARS	INFORMAL MESSAGE	INFORMAL MESSAGING	INFORMAL MESSAGING	CORE SERVICES
DARS	INSTANT MESSAGE	INSTANT MESSAGING	JOINT COI SERVICE	COI SERVICES
DARS	MOVEMENTS AND TRANSPORTATION INFO	REPORTS	LOGISTICS COI SERVICE	COI SERVICES
DARS	SUPPLIES AND MATERIAL	RESOURCE STATUS	LOGISTICS COI SERVICE	COI SERVICES
DARS	VOICE (NON-SECURE)	VOICE	VOICE	CORE SERVICES
DARS	VOICE (SECURE)	VOICE	VOICE	CORE SERVICES
DARS	VTC	VTC	VTC	CORE SERVICES
DOB1/APOD	FAX	FAX	FAX	CORE SERVICES
DOB1/APOD	FORMAL MESSAGE	FORMAL MESSAGING	FORMAL MESSAGING SERVICE	CORE ENTERPRISE SERVICES
DOB1/APOD	INFORMAL MESSAGE	INFORMAL MESSAGING	INFORMAL MESSAGING	CORE SERVICES
DOB1/APOD	INSTANT MESSAGE	INSTANT MESSAGING	JOINT COI SERVICE	COI SERVICES
DOB1/APOD	MOVEMENTS AND TRANSPORTATION INFO	REPORTS	LOGISTICS COI SERVICE	COI SERVICES
DOB1/APOD	SUPPLIES AND MATERIAL	RESOURCE STATUS	LOGISTICS COI SERVICE	COI SERVICES
DOB1/APOD	VOICE (NON-SECURE)	VOICE	VOICE	CORE SERVICES
DOB1/APOD	VOICE (SECURE)	VOICE	VOICE	CORE SERVICES
DOB1/APOD	VTC	VTC	VTC	CORE SERVICES
HN/ GO/ NGO/ IO	CONTRACTING INFO	FINANCIAL SERVICES	BUSINESS SUPPORT SERVICE	COI SERVICES
HN/ GO/ NGO/ IO	FAX	FAX	FAX	CORE SERVICES
HN/ GO/ NGO/ IO	PORTAL SERVICES	PORTAL SERVICES	INFORMATION MANAGEMENT SERVICES	CORE ENTERPRISE SERVICES
HN/ GO/ NGO/ IO	MOVEMENTS AND TRANSPORTATION INFO	REPORTS	LOGISTICS COI SERVICE	COI SERVICES
HN/ GO/ NGO/ IO	VOICE (NON-SECURE)	VOICE	VOICE	CORE SERVICES
JHQ STATIC	FAX	FAX	FAX	CORE SERVICES
JHQ STATIC	FORMAL MESSAGE	FORMAL MESSAGING	FORMAL MESSAGING SERVICE	CORE ENTERPRISE SERVICES
JHQ STATIC	INFORMAL MESSAGE	INFORMAL MESSAGING	INFORMAL MESSAGING	CORE SERVICES
JHQ STATIC	VOICE (NON-SECURE)	VOICE	VOICE	CORE SERVICES
JHQ STATIC	VOICE (SECURE)	VOICE	VOICE	CORE SERVICES
JHQ STATIC	VTC	VTC	VTC	CORE SERVICES
JTF HQ	DIRECTORY SYNC	DIRECTORY SERVICES	DIRECTORY SERVICES	CORE SERVICES
JTF HQ	FAX	FAX	FAX	CORE SERVICES
JTF HQ	FORMAL MESSAGE	FORMAL MESSAGING	FORMAL MESSAGING SERVICE	CORE ENTERPRISE SERVICES
JTF HQ	INFORMAL MESSAGE	INFORMAL MESSAGING	INFORMAL MESSAGING	CORE SERVICES

IER TO	IE PRODUCT	USER SERVICE DEFINITION: OPERATIONAL CAPABILITY	TECHNICAL SERVICE LEVEL2	TECHNICAL SERVICE LEVEL 1
JTF HQ	INSTANT MESSAGE	INSTANT MESSAGING	JOINT COI SERVICE	COI SERVICES
JTF HQ	OPLAN	PLANS	JOINT COI SERVICE	COI SERVICES
JTF HQ	FRAGO	TASKING & ORDERS	JOINT COI SERVICE	COI SERVICES
JTF HQ	JCO	TASKING & ORDERS	JOINT COI SERVICE	COI SERVICES
JTF HQ	MOVEMENTS AND TRANSPORTATION INFO	REPORTS	LOGISTICS COI SERVICE	COI SERVICES
JTF HQ	SUPPLIES AND MATERIAL	RESOURCE STATUS	LOGISTICS COI SERVICE	COI SERVICES
JTF HQ	OFFICE COLLABORATION (AUDIO)	COLLABORATION	UNIFIED COMM. & COLLAB SERVICES	CORE ENTERPRISE SERVICES
JTF HQ	OFFICE COLLABORATION (AV)	COLLABORATION	UNIFIED COMM. & COLLAB SERVICES	CORE ENTERPRISE SERVICES
JTF HQ	OFFICE COLLABORATION (CHAT)	COLLABORATION	UNIFIED COMM. & COLLAB SERVICES	CORE ENTERPRISE SERVICES
JTF HQ	OFFICE COLLABORATION (WHITEBOARD)	COLLABORATION	UNIFIED COMM. & COLLAB SERVICES	CORE ENTERPRISE SERVICES
JTF HQ	VOICE (NON-SECURE)	VOICE	VOICE	CORE SERVICES
JTF HQ	VOICE (SECURE)	VOICE	VOICE	CORE SERVICES
JTF HQ	VTC	VTC	VTC	CORE SERVICES
LCC	FAX	FAX	FAX	CORE SERVICES
LCC	FORMAL MESSAGE	FORMAL MESSAGING	FORMAL MESSAGING SERVICE	CORE ENTERPRISE SERVICES
LCC	INFORMAL MESSAGE	INFORMAL MESSAGING	INFORMAL MESSAGING	CORE SERVICES
LCC	INSTANT MESSAGE	INSTANT MESSAGING	JOINT COI SERVICE	COI SERVICES
LCC	MOVEMENTS AND TRANSPORTATION INFO	REPORTS	LOGISTICS COI SERVICE	COI SERVICES
LCC	SUPPLIES AND MATERIAL	RESOURCE STATUS	LOGISTICS COI SERVICE	COI SERVICES
LCC	VOICE (NON-SECURE)	VOICE	VOICE	CORE SERVICES
LCC	VOICE (SECURE)	VOICE	VOICE	CORE SERVICES
LCC	VTC	VTC	VTC	CORE SERVICES
MCC	FAX	FAX	FAX	CORE SERVICES
MCC	FORMAL MESSAGE	FORMAL MESSAGING	FORMAL MESSAGING SERVICE	CORE ENTERPRISE SERVICES
MCC	INFORMAL MESSAGE	INFORMAL MESSAGING	INFORMAL MESSAGING	CORE SERVICES
MCC	INSTANT MESSAGE	INSTANT MESSAGING	JOINT COI SERVICE	COI SERVICES
MCC	MOVEMENTS AND TRANSPORTATION INFO	REPORTS	LOGISTICS COI SERVICE	COI SERVICES
MCC	SUPPLIES AND MATERIAL	RESOURCE STATUS	LOGISTICS COI SERVICE	COI SERVICES
MCC	VOICE (NON-SECURE)	VOICE	VOICE	CORE SERVICES
MCC	VOICE (SECURE)	VOICE	VOICE	CORE SERVICES
MCC	VTC	VTC	VTC	CORE SERVICES
NAEW/DOB3	FAX	FAX	FAX	CORE SERVICES
NAEW/DOB3	FORMAL MESSAGE	FORMAL MESSAGING	FORMAL MESSAGING SERVICE	CORE ENTERPRISE SERVICES
NAEW/DOB3	INFORMAL MESSAGE	INFORMAL MESSAGING	INFORMAL MESSAGING	CORE SERVICES
NAEW/DOB3	INSTANT MESSAGE	INSTANT MESSAGING	JOINT COI SERVICE	COI SERVICES
NAEW/DOB3	MOVEMENTS AND TRANSPORTATION INFO	REPORTS	LOGISTICS COI SERVICE	COI SERVICES
NAEW/DOB3	SUPPLIES AND MATERIAL	RESOURCE STATUS	LOGISTICS COI SERVICE	COI SERVICES
NAEW/DOB3	VOICE (NON-SECURE)	VOICE	VOICE	CORE SERVICES
NAEW/DOB3	VOICE (SECURE)	VOICE	VOICE	CORE SERVICES
NAEW/DOB3	VTC	VTC	VTC	CORE SERVICES
PODS/DOBS	FAX	FAX	FAX	CORE SERVICES
PODS/DOBS	FORMAL MESSAGE	FORMAL MESSAGING	FORMAL MESSAGING SERVICE	CORE ENTERPRISE SERVICES
PODS/DOBS	INFORMAL MESSAGE	INFORMAL MESSAGING	INFORMAL MESSAGING	CORE SERVICES
PODS/DOBS	INSTANT MESSAGE	INSTANT MESSAGING	JOINT COI SERVICE	COI SERVICES
PODS/DOBS	MOVEMENTS AND TRANSPORTATION INFO	REPORTS	LOGISTICS COI SERVICE	COI SERVICES
PODS/DOBS	SUPPLIES AND MATERIAL	RESOURCE STATUS	LOGISTICS COI SERVICE	COI SERVICES
PODS/DOBS	VOICE (NON-SECURE)	VOICE	VOICE	CORE SERVICES
PODS/DOBS	VOICE (SECURE)	VOICE	VOICE	CORE SERVICES
PODS/DOBS	VTC	VTC	VTC	CORE SERVICES
SOCC	FAX	FAX	FAX	CORE SERVICES
SOCC	FORMAL MESSAGE	FORMAL MESSAGING	FORMAL MESSAGING SERVICE	CORE ENTERPRISE SERVICES
SOCC	INFORMAL MESSAGE	INFORMAL MESSAGING	INFORMAL MESSAGING	CORE SERVICES
SOCC	INSTANT MESSAGE	INSTANT MESSAGING	JOINT COI SERVICE	COI SERVICES
SOCC	MOVEMENTS AND TRANSPORTATION INFO	REPORTS	LOGISTICS COI SERVICE	COI SERVICES
SOCC	SUPPLIES AND MATERIAL	RESOURCE STATUS	LOGISTICS COI SERVICE	COI SERVICES
SOCC	VOICE (NON-SECURE)	VOICE	VOICE	CORE SERVICES
SOCC	VOICE (SECURE)	VOICE	VOICE	CORE SERVICES
SOCC	VTC	VTC	VTC	CORE SERVICES

Table D-II-6-2: JLSG Uni-directional Information Products Disseminated

IER TO	IE PRODUCT	USER SERVICE DEFINITION: OPERATIONAL CAPABILITY	TECHNICAL SERVICE LEVEL2	TECHNICAL SERVICE LEVEL 1
JFAC/AOC	RLP	SITUATIONAL AWARENESS	LOGISTICS COI SERVICE	COI SERVICES
CBRN	RLP	SITUATIONAL AWARENESS	LOGISTICS COI SERVICE	COI SERVICES
DARS	RLP	SITUATIONAL AWARENESS	LOGISTICS COI SERVICE	COI SERVICES
DOB1/APOD	RLP	SITUATIONAL AWARENESS	LOGISTICS COI SERVICE	COI SERVICES
JTF HQ	CIS SITREP	REPORTS	JOINT NOC SERVICES	SMC
JTF HQ	MEDSITREP	MEDICAL	LOGISTICS COI SERVICE	COI SERVICES
JTF HQ	LOGASSESSREP	REPORTS	LOGISTICS COI SERVICE	COI SERVICES
JTF HQ	RLP	SITUATIONAL AWARENESS	LOGISTICS COI SERVICE	COI SERVICES
LCC	RLP	SITUATIONAL AWARENESS	LOGISTICS COI SERVICE	COI SERVICES
MCC	RLP	SITUATIONAL AWARENESS	LOGISTICS COI SERVICE	COI SERVICES
NAEW/DOB3	RLP	SITUATIONAL AWARENESS	LOGISTICS COI SERVICE	COI SERVICES
PODS/DOBS	RLP	SITUATIONAL AWARENESS	LOGISTICS COI SERVICE	COI SERVICES
SOCC	RLP	SITUATIONAL AWARENESS	LOGISTICS COI SERVICE	COI SERVICES

Table D-II-6-3: JLSG Uni-directional Information Products Consumed

IER FROM	IE PRODUCT	USER SERVICE DEFINITION: OPERATIONAL CAPABILITY	TECHNICAL SERVICE LEVEL2	TECHNICAL SERVICE LEVEL 1
JFAC/AOC	LOGASSESSREP	REPORTS	LOGISTICS COI SERVICE	COI SERVICES
JFAC/AOC	TMD INFO	TMD INFO	MISSILE DEFENCE COI SERVICE	COI SERVICES
CBRN	LOGASSESSREP	REPORTS	LOGISTICS COI SERVICE	COI SERVICES
JTF HQ	METEO INFO	METEO	ENVIRONMENTAL COI SERVICE	COI SERVICES
JTF HQ	CONTAMINATION REPORTS	NBC	ENVIRONMENTAL COI SERVICE	COI SERVICES
JTF HQ	GEO INFORMATION	GEO SERVICES	GEOSPATIAL SERVICES	CORE ENTERPRISE SERVICES
JTF HQ	WARNORD	INTENT & GUIDANCE	JOINT COI SERVICE	COI SERVICES
JTF HQ	COP	SITUATIONAL AWARENESS	JOINT COI SERVICE	COI SERVICES
JTF HQ	CIS PICTURE	SITUATIONAL AWARENESS	JOINT NOC SERVICES	SMC
LCC	LOGASSESSREP	REPORTS	LOGISTICS COI SERVICE	COI SERVICES
MCC	LOGASSESSREP	REPORTS	LOGISTICS COI SERVICE	COI SERVICES
SOCC	LOGASSESSREP	REPORTS	LOGISTICS COI SERVICE	COI SERVICES

D-II-7 Information Exchange Requirements OLRT.

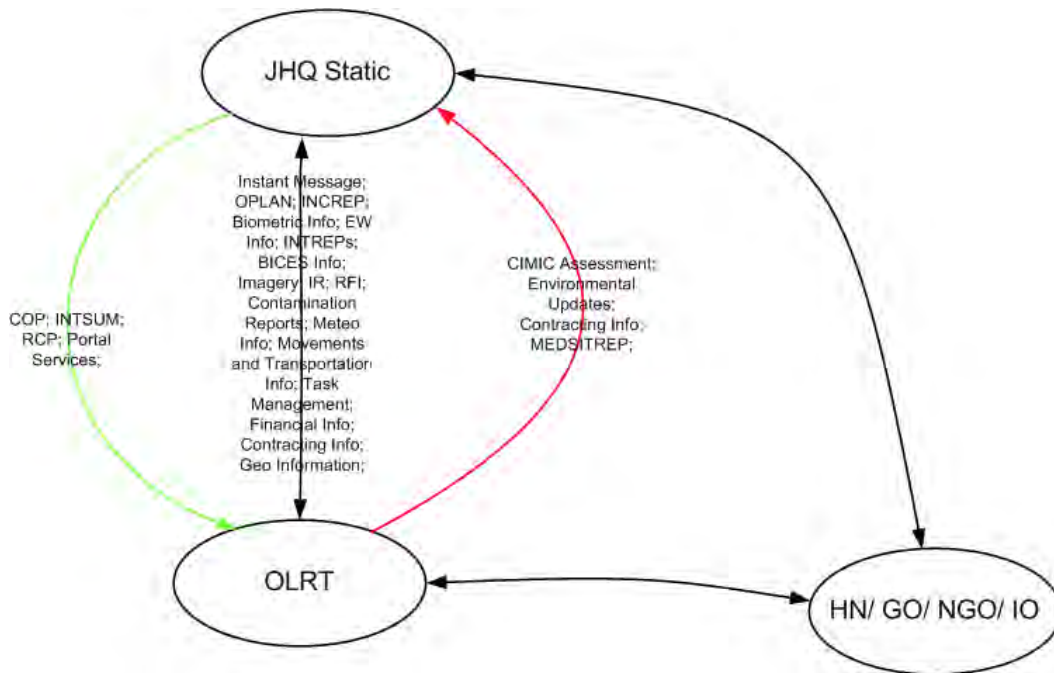

Figure D-II-7-1: C2 Information Product Exchange OLRT

Specific C2 information product exchange for the OLRT is depicted in Figure D-II-7-1. The bi-directional black arrow represents bi-directional exchange of information products, further detailed in Table D-II-7-1. The unidirectional red arrow shows information products sent from the OLRT to other C2 entities, further detailed in Table D-II-7-2. Finally, the green unidirectional arrows represent information products sent to and consumed by the OLRT. These product exchanges are further detailed in Table D-II-7-3.

The bi-directional Information Exchange Requirements between the OLRT and the other relevant C2 entities, as introduced in Figure D-1-1 and D-II-7-1 are depicted in Table D-II-7-1. The column “IERs To” lists the C2 entity the information products are exchanged with (in both directions), the second column lists the product that is exchanged. The operational capability the product supports is given in column 3, while columns 4 and 5 provide the technical services at Level 2 and Level 1.

The information products disseminated from the OLRT to the other relevant C2 entities, as introduced in Figure D-II-7-1, are depicted in Table D-II-7-2.

Finally, Table D-II-7-3 contains the unidirectional information products consumed by the OLRT, as introduced in Figure D-II-7-1.

Table D-II-7-1: OLRT Bi-directional IERs

IER TO	IE PRODUCT	USER SERVICE DEFINITION: OPERATIONAL CAPABILITY	TECHNICAL SERVICE LEVEL2	TECHNICAL SERVICE LEVEL 1
HN/ GO/ NGO/ IO	FAX	FAX	FAX	CORE SERVICES
HN/ GO/ NGO/ IO	INFORMAL MESSAGE	INFORMAL MESSAGING	INFORMAL MESSAGING	CORE SERVICES
HN/ GO/ NGO/ IO	VOICE (NON-SECURE)	VOICE	VOICE	CORE SERVICES
JHQ STATIC	CONTRACTING INFO	FINANCIAL SERVICES	BUSINESS SUPPORT SERVICE	COI SERVICES
JHQ STATIC	FINANCIAL INFO	FINANCIAL SERVICES	BUSINESS SUPPORT SERVICE	COI SERVICES
JHQ STATIC	METEO INFO	METEO	ENVIRONMENTAL COI SERVICE	COI SERVICES
JHQ STATIC	CONTAMINATION REPORTS	NBC	ENVIRONMENTAL COI SERVICE	COI SERVICES
JHQ STATIC	FAX	FAX	FAX	CORE SERVICES
JHQ STATIC	FORMAL MESSAGE	FORMAL MESSAGING	FORMAL MESSAGING SERVICE	CORE ENTERPRISE SERVICES
JHQ STATIC	GEO INFORMATION	GEO SERVICES	GEOSPATIAL SERVICES	CORE ENTERPRISE SERVICES
JHQ STATIC	INFORMAL MESSAGE	INFORMAL MESSAGING	INFORMAL MESSAGING	CORE SERVICES
JHQ STATIC	BICES INFO	BICES INFO	JISR COI SERVICE	COI SERVICES
JHQ STATIC	IMAGERY	INTEL DATABASE SERVICES	JISR COI SERVICE	COI SERVICES
JHQ STATIC	BIOMETRIC INFO	REPORTS	JISR COI SERVICE	COI SERVICES
JHQ STATIC	EW INFO	REPORTS	JISR COI SERVICE	COI SERVICES
JHQ STATIC	INTREPS	REPORTS	JISR COI SERVICE	COI SERVICES
JHQ STATIC	IR	REQUESTS AND RESPONSES	JISR COI SERVICE	COI SERVICES
JHQ STATIC	RFI	REQUESTS AND RESPONSES	JISR COI SERVICE	COI SERVICES
JHQ STATIC	INSTANT MESSAGE	INSTANT MESSAGING	JOINT COI SERVICE	COI SERVICES
JHQ STATIC	OPLAN	PLANS	JOINT COI SERVICE	COI SERVICES
JHQ STATIC	INCREP	REPORTS	JOINT COI SERVICE	COI SERVICES
JHQ STATIC	MOVEMENTS AND TRANSPORTATION INFO	REPORTS	LOGISTICS COI SERVICE	COI SERVICES
JHQ STATIC	TASK MANAGEMENT	TASK MGT	TASKING AND ORDER SERVICES	COI SERVICES
JHQ STATIC	OFFICE COLLABORATION (AUDIO)	COLLABORATION	UNIFIED COMM. & COLLAB. SERVICES	CORE ENTERPRISE SERVICES
JHQ STATIC	OFFICE COLLABORATION (AV)	COLLABORATION	UNIFIED COMM. & COLLAB. SERVICES	CORE ENTERPRISE SERVICES
JHQ STATIC	OFFICE COLLABORATION (CHAT)	COLLABORATION	UNIFIED COMM. & COLLAB. SERVICES	CORE ENTERPRISE SERVICES
JHQ STATIC	OFFICE COLLABORATION (WHITEBOARD)	COLLABORATION	UNIFIED COMM. & COLLAB. SERVICES	CORE ENTERPRISE SERVICES
JHQ STATIC	VOICE (NON-SECURE)	VOICE	VOICE	CORE SERVICES
JHQ STATIC	VOICE (SECURE)	VOICE	VOICE	CORE SERVICES

Table D-II-7-2: OLRT Uni-directional Information Products Disseminated

IER TO	IE PRODUCT	USER SERVICE DEFINITION: OPERATIONAL CAPABILITY	TECHNICAL SERVICE LEVEL2	TECHNICAL SERVICE LEVEL 1
JHQ STATIC	CONTRACTING INFO	FINANCIAL SERVICES	BUSINESS SUPPORT SERVICE	COI SERVICES
JHQ STATIC	CIMIC ASSESSMENT	SITUATIONAL AWARENESS	CIMIC COI SERVICE	COI SERVICES
JHQ STATIC	ENVIRONMENTAL UPDATES	SITUATIONAL AWARENESS	ENVIRONMENTAL COI SERVICE	COI SERVICES
JHQ STATIC	CIS SITREP	REPORTS	JOINT NOC SERVICES	SMC
JHQ STATIC	MEDSITREP	MEDICAL	LOGISTICS COI SERVICE	COI SERVICES

Table D-II-7-3: OLRT Uni-directional Information Products Consumed

IER FROM	IE PRODUCT	USER SERVICE DEFINITION: OPERATIONAL CAPABILITY	TECHNICAL SERVICE LEVEL2	TECHNICAL SERVICE LEVEL 1
HN/ GO/ NGO/ IO	PORTAL SERVICES	PORTAL SERVICES	INFORMATION MANAGEMENT SERVICES	CORE ENTERPRISE SERVICES
JHQ STATIC	RCP	SITUATIONAL AWARENESS	CIMIC COI SERVICE	COI SERVICES
JHQ STATIC	PORTAL SERVICES	PORTAL SERVICES	INFORMATION MANAGEMENT SERVICES	CORE ENTERPRISE SERVICES
JHQ STATIC	INTSUM	REPORTS	JISR COI SERVICE	COI SERVICES
JHQ STATIC	COP	SITUATIONAL AWARENESS	JOINT COI SERVICE	COI SERVICES
JHQ STATIC	CIS PICTURE	SITUATIONAL AWARENESS	JOINT NOC SERVICES	SMC

D-II-8 Information Exchange Requirements POD /DOB.

For further study.

D-II-9 Information Exchange Requirements TLT.

For further study.

D-II-10 Information Exchange Requirements POCC.

For further study.

D-II-11 Information Exchange Requirements CBRN.

For further study.

D-II-12 Information Exchange Requirements Theatre Reserve.

For further study.

D-II-13 Information Exchange Requirements FLSB.

For further study.

D-II-14 Information Exchange Requirements NAEW.

For further study.

D-II-15 Information Exchange Requirements Theatre DARS.

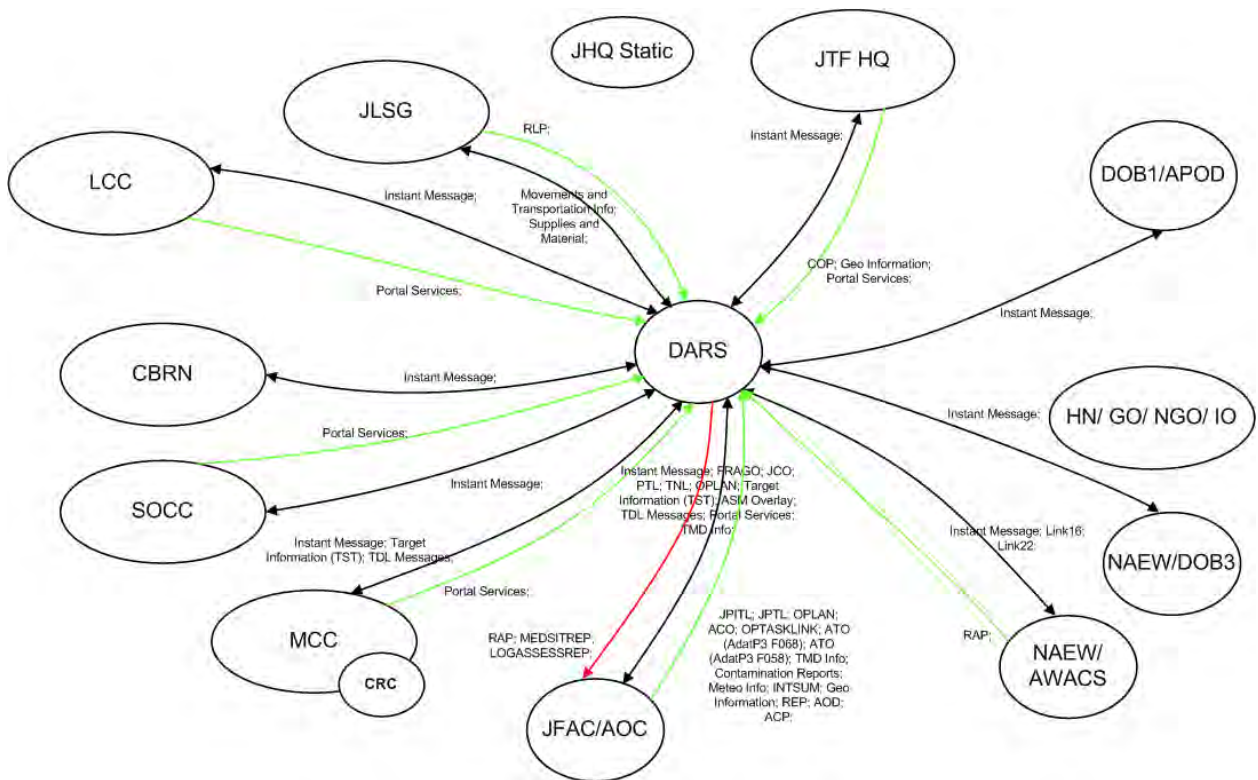

Figure D-II-15-1: C2 Information Product Exchange DARS

Specific C2 information product exchange for the DARS is depicted in Figure D-II-15-1. The bi-directional black arrow represents bi-directional exchange of information products, further detailed in Table D-II-15-1. The unidirectional red arrow shows information products sent from the DARS to other C2 entities, further detailed in Table D-II-15-2. Finally, the green unidirectional arrows represent information products sent to and consumed by the DARS. These product exchanges are further detailed in Table D-II-15-3.

The bi-directional Information Exchange Requirements between the DARS and the other relevant C2 entities, as introduced in Figure D-1-1 and D-II-15-1 are depicted in Table D-II-15-1. The column “IERs To” lists the C2 entity the information products are exchanged with (in both directions), the second column lists the product that is exchanged. The operational capability the product supports is given in column 3, while columns 4 and 5 provide the technical services at Level 2 and Level 1.

The information products disseminated from the DARS to the other relevant C2 entities, as introduced in Figure D-II-15-1, are depicted in Table D-II-15-2.

Finally, Table D-II-15-3 contains the unidirectional information products consumed by the DARS, as introduced in Figure D-II-15-1.

Table D-II-15-1: DARS Bi-directional IERs

IER TO	IE PRODUCT	USER SERVICE DEFINITION: OPERATIONAL CAPABILITY	TECHNICAL SERVICE LEVEL2	TECHNICAL SERVICE LEVEL 1
JFAC/AOC	TDL MESSAGES	SITUATIONAL AWARENESS	AIR COI SERVICE	COI SERVICES
JFAC/AOC	DIRECTORY SYNC	DIRECTORY SERVICES	DIRECTORY SERVICES	CORE SERVICES
JFAC/AOC	FAX	FAX	FAX	CORE SERVICES
JFAC/AOC	FORMAL MESSAGE	FORMAL MESSAGING	FORMAL MESSAGING SERVICE	CORE ENTERPRISE SERVICES
JFAC/AOC	INFORMAL MESSAGE	INFORMAL MESSAGING	INFORMAL MESSAGING	CORE SERVICES
JFAC/AOC	PORTAL SERVICES	PORTAL SERVICES	INFORMATION MANAGEMENT SERVICES	CORE ENTERPRISE SERVICES
JFAC/AOC	INSTANT MESSAGE	INSTANT MESSAGING	JOINT COI SERVICE	COI SERVICES
JFAC/AOC	PTL	JOINT TARGETING	JOINT COI SERVICE	COI SERVICES
JFAC/AOC	TNL	JOINT TARGETING	JOINT COI SERVICE	COI SERVICES
JFAC/AOC	OPLAN	PLANS	JOINT COI SERVICE	COI SERVICES
JFAC/AOC	FRAGO	TASKING & ORDERS	JOINT COI SERVICE	COI SERVICES
JFAC/AOC	JCO	TASKING & ORDERS	JOINT COI SERVICE	COI SERVICES
JFAC/AOC	TARGET INFORMATION (TST)	TIME SENSITIVE TARGETING	JOINT COI SERVICE	COI SERVICES
JFAC/AOC	TMD INFO	TMD INFO	MISSILE DEFENCE COI SERVICE	COI SERVICES
JFAC/AOC	OFFICE COLLABORATION (AUDIO)	COLLABORATION	UNIFIED COMM. & COLLAB SERVICES	CORE ENTERPRISE SERVICES
JFAC/AOC	OFFICE COLLABORATION (AV)	COLLABORATION	UNIFIED COMM. & COLLAB SERVICES	CORE ENTERPRISE SERVICES
JFAC/AOC	OFFICE COLLABORATION (CHAT)	COLLABORATION	UNIFIED COMM. & COLLAB SERVICES	CORE ENTERPRISE SERVICES
JFAC/AOC	OFFICE COLLABORATION (WHITEBOARD)	COLLABORATION	UNIFIED COMM. & COLLAB SERVICES	CORE ENTERPRISE SERVICES
JFAC/AOC	VOICE (NON-SECURE)	VOICE	VOICE	CORE SERVICES
JFAC/AOC	VOICE (SECURE)	VOICE	VOICE	CORE SERVICES
JFAC/AOC	VTC	VTC	VTC	CORE SERVICES
AWACS	LINK16	SITUATIONAL AWARENESS	AIR COI SERVICE	COI SERVICES
AWACS	LINK22	SITUATIONAL AWARENESS	AIR COI SERVICE	COI SERVICES
AWACS	INSTANT MESSAGE	INSTANT MESSAGING	JOINT COI SERVICE	COI SERVICES
AWACS	VOICE (NON-SECURE)	VOICE	VOICE	CORE SERVICES
AWACS	VOICE (SECURE)	VOICE	VOICE	CORE SERVICES
BDE	FAX	FAX	FAX	CORE SERVICES
BDE	INSTANT MESSAGE	INSTANT MESSAGING	JOINT COI SERVICE	COI SERVICES
BDE	VOICE (NON-SECURE)	VOICE	VOICE	CORE SERVICES
BDE	VOICE (SECURE)	VOICE	VOICE	CORE SERVICES
CBRN	FAX	FAX	FAX	CORE SERVICES
CBRN	INSTANT MESSAGE	INSTANT MESSAGING	JOINT COI SERVICE	COI SERVICES
CBRN	VOICE (NON-SECURE)	VOICE	VOICE	CORE SERVICES
CBRN	VOICE (SECURE)	VOICE	VOICE	CORE SERVICES
DOB1/APOD	FAX	FAX	FAX	CORE SERVICES
DOB1/APOD	INSTANT MESSAGE	INSTANT MESSAGING	JOINT COI SERVICE	COI SERVICES
DOB1/APOD	VOICE (NON-SECURE)	VOICE	VOICE	CORE SERVICES
DOB1/APOD	VOICE (SECURE)	VOICE	VOICE	CORE SERVICES
HN/ GO/ NGO/ IO	FAX	FAX	FAX	CORE SERVICES
HN/ GO/ NGO/ IO	INSTANT MESSAGE	INSTANT MESSAGING	JOINT COI SERVICE	COI SERVICES
HN/ GO/ NGO/ IO	VOICE (NON-SECURE)	VOICE	VOICE	CORE SERVICES
JHQ STATIC	FAX	FAX	FAX	CORE SERVICES
JHQ STATIC	INSTANT MESSAGE	INSTANT MESSAGING	JOINT COI SERVICE	COI SERVICES
JHQ STATIC	VOICE (NON-SECURE)	VOICE	VOICE	CORE SERVICES
JHQ STATIC	VOICE (SECURE)	VOICE	VOICE	CORE SERVICES
JLSG	FAX	FAX	FAX	CORE SERVICES
JLSG	INFORMAL MESSAGE	INFORMAL MESSAGING	INFORMAL MESSAGING	CORE SERVICES
JLSG	MOVEMENTS AND TRANSPORTATION INFO	REPORTS	LOGISTICS COI SERVICE	COI SERVICES
JLSG	SUPPLIES AND MATERIAL	RESOURCE STATUS	LOGISTICS COI SERVICE	COI SERVICES
JLSG	VOICE (NON-SECURE)	VOICE	VOICE	CORE SERVICES
JLSG	VOICE (SECURE)	VOICE	VOICE	CORE SERVICES
JTF HQ	FAX	FAX	FAX	CORE SERVICES
JTF HQ	INFORMAL MESSAGE	INFORMAL MESSAGING	INFORMAL MESSAGING	CORE SERVICES
JTF HQ	INSTANT MESSAGE	INSTANT MESSAGING	JOINT COI SERVICE	COI SERVICES
JTF HQ	VOICE (NON-SECURE)	VOICE	VOICE	CORE SERVICES
JTF HQ	VOICE (SECURE)	VOICE	VOICE	CORE SERVICES

IER TO	IE PRODUCT	USER SERVICE DEFINITION: OPERATIONAL CAPABILITY	TECHNICAL SERVICE LEVEL2	TECHNICAL SERVICE LEVEL 1
LCC	FAX	FAX	FAX	CORE SERVICES
LCC	INSTANT MESSAGE	INSTANT MESSAGING	JOINT COI SERVICE	COI SERVICES
LCC	VOICE (NON-SECURE)	VOICE	VOICE	CORE SERVICES
LCC	VOICE (SECURE)	VOICE	VOICE	CORE SERVICES
MCC	TDL MESSAGES	SITUATIONAL AWARENESS	AIR COI SERVICE	COI SERVICES
MCC	FAX	FAX	FAX	CORE SERVICES
MCC	FORMAL MESSAGE	FORMAL MESSAGING	FORMAL MESSAGING SERVICE	CORE ENTERPRISE SERVICES
MCC	INFORMAL MESSAGE	INFORMAL MESSAGING	INFORMAL MESSAGING	CORE SERVICES
MCC	INSTANT MESSAGE	INSTANT MESSAGING	JOINT COI SERVICE	COI SERVICES
MCC	TARGET INFORMATION (TST)	TIME SENSITIVE TARGETING	JOINT COI SERVICE	COI SERVICES
MCC	VOICE (NON-SECURE)	VOICE	VOICE	CORE SERVICES
MCC	VOICE (SECURE)	VOICE	VOICE	CORE SERVICES
MCC	VTC	VTC	VTC	CORE SERVICES
NAEW/DOB3	FAX	FAX	FAX	CORE SERVICES
NAEW/DOB3	INSTANT MESSAGE	INSTANT MESSAGING	JOINT COI SERVICE	COI SERVICES
NAEW/DOB3	VOICE (NON-SECURE)	VOICE	VOICE	CORE SERVICES
NAEW/DOB3	VOICE (SECURE)	VOICE	VOICE	CORE SERVICES
PODS/DOBS	FAX	FAX	FAX	CORE SERVICES
PODS/DOBS	INSTANT MESSAGE	INSTANT MESSAGING	JOINT COI SERVICE	COI SERVICES
PODS/DOBS	VOICE (NON-SECURE)	VOICE	VOICE	CORE SERVICES
PODS/DOBS	VOICE (SECURE)	VOICE	VOICE	CORE SERVICES
SOCC	FAX	FAX	FAX	CORE SERVICES
SOCC	FORMAL MESSAGE	FORMAL MESSAGING	FORMAL MESSAGING SERVICE	CORE ENTERPRISE SERVICES
SOCC	INFORMAL MESSAGE	INFORMAL MESSAGING	INFORMAL MESSAGING	CORE SERVICES
SOCC	INSTANT MESSAGE	INSTANT MESSAGING	JOINT COI SERVICE	COI SERVICES
SOCC	VOICE (NON-SECURE)	VOICE	VOICE	CORE SERVICES
SOCC	VOICE (SECURE)	VOICE	VOICE	CORE SERVICES
SOCC	VTC	VTC	VTC	CORE SERVICES

Table D-II-15-2: DARS Uni-directional Information Products Disseminated

IER TO	IE PRODUCT	USER SERVICE DEFINITION: OPERATIONAL CAPABILITY	TECHNICAL SERVICE LEVEL2	TECHNICAL SERVICE LEVEL 1
JFAC/AOC	RAP	SITUATIONAL AWARENESS	AIR COI SERVICE	COI SERVICES
JFAC/AOC	CIS SITREP	REPORTS	JOINT NOC SERVICES	SMC
JFAC/AOC	MEDSITREP	MEDICAL	LOGISTICS COI SERVICE	COI SERVICES
JFAC/AOC	LOGASSESSREP	REPORTS	LOGISTICS COI SERVICE	COI SERVICES
JTF HQ	CIS SITREP	REPORTS	JOINT NOC SERVICES	SMC

Table D-II-15-3: DARS Uni-directional Information Products Consumed

IER FROM	IE PRODUCT	USER SERVICE DEFINITION: OPERATIONAL CAPABILITY	TECHNICAL SERVICE LEVEL2	TECHNICAL SERVICE LEVEL 1
JFAC/AOC	AOD	INTENT & GUIDANCE	AIR COI SERVICE	COI SERVICES
JFAC/AOC	ACP	PLANS	AIR COI SERVICE	COI SERVICES
JFAC/AOC	ACO	TASKING & ORDERS	AIR COI SERVICE	COI SERVICES
JFAC/AOC	ATO (ADATP3 F058)	TASKING & ORDERS	AIR COI SERVICE	COI SERVICES
JFAC/AOC	ATO (ADATP3 F068)	TASKING & ORDERS	AIR COI SERVICE	COI SERVICES
JFAC/AOC	OPTASKLINK	TASKING & ORDERS	AIR COI SERVICE	COI SERVICES
JFAC/AOC	METEO INFO	METEO	ENVIRONMENTAL COI SERVICE	COI SERVICES
JFAC/AOC	CONTAMINATION REPORTS	NBC	ENVIRONMENTAL COI SERVICE	COI SERVICES
JFAC/AOC	REP	SITUATIONAL AWARENESS	ENVIRONMENTAL COI SERVICE	COI SERVICES
JFAC/AOC	GEO INFORMATION	GEO SERVICES	GEOSPATIAL SERVICES	CORE ENTERPRISE SERVICES
JFAC/AOC	INTSUM	REPORTS	JISR COI SERVICE	COI SERVICES
JFAC/AOC	JPITL	JOINT TARGETING	JOINT COI SERVICE	COI SERVICES
JFAC/AOC	JPTL	JOINT TARGETING	JOINT COI SERVICE	COI SERVICES
JFAC/AOC	OPLAN	PLANS	JOINT COI SERVICE	COI SERVICES
JFAC/AOC	TMD INFO	TMD INFO	MISSILE DEFENCE COI SERVICE	COI SERVICES
AWACS	RAP	SITUATIONAL AWARENESS	AIR COI SERVICE	COI SERVICES
JHQ STATIC	PORTAL SERVICES	PORTAL SERVICES	INFORMATION MANAGEMENT SERVICES	CORE ENTERPRISE SERVICES
JLSG	RLP	SITUATIONAL AWARENESS	LOGISTICS COI SERVICE	COI SERVICES
JTF HQ	GEO INFORMATION	GEO SERVICES	GEOSPATIAL SERVICES	CORE ENTERPRISE SERVICES
JTF HQ	PORTAL SERVICES	PORTAL SERVICES	INFORMATION MANAGEMENT SERVICES	CORE ENTERPRISE SERVICES
JTF HQ	COP	SITUATIONAL AWARENESS	JOINT COI SERVICE	COI SERVICES
MCC	PORTAL SERVICES	PORTAL SERVICES	INFORMATION MANAGEMENT SERVICES	CORE ENTERPRISE SERVICES
SOCC	PORTAL SERVICES	PORTAL SERVICES	INFORMATION MANAGEMENT SERVICES	CORE ENTERPRISE SERVICES

CIS INTEROPERABILITY REQUIREMENT TABLES FOR IOP2A

This Annex defines the CIS interoperability requirements between the C2 entities of a NATO led operations. Its scope is currently limited to interconnection level 2a as introduced with Figure 3-5 and Figure 3-6. The basic network transport services required to support the information exchange are introduced, and each user service is mapped to one or more network transport services that it can use to traverse the INM into the NATO provided core network.

General. The conduct of operations requires a wide range of information exchange capabilities based on platform types and designated command functions. The following tables are developed to define CIS Interoperability requirements for each C2 entity to meet NATO's MMRs and are derived from the recommendations of the DCIS Target Architecture and DCIS CONOPS. Tables have been constructed to reflect the required standards for interfaces, protocols, waveforms and FS versions and platforms to achieve interoperability within a NATO led land-based deployed operation.

For Interoperability Point 2a, the Network transport services requirements and the COI to Network service mappings are depicted in Table E-1 and E-2. Details on the various layer protocols including a mapping to NSIP profiles will be presented in a technical document supporting the implementation of MC 0593.

It is understood that Annexes E and G shall provide IERs and interoperability standards only. However, due to the fact interoperability standards are not fully developed and agreed, today a major portion of the requirements are expressed by asking for a common tool to be used. Over time, and as protocol standards to be used are agreed, it will be up to the each participant/nation to decide whether to use the NATO provided CES/COI, or to develop her own solution compliant with the IERs and mandatory protocol standards. Future updates of the technical Annexes will honour those developments.

At the moment, on NU and internet level mainly voice, VTC, mail, fax and portal services are mandatory. Only limited COI services like financial services (CNAFS), Meteorological (NAMIS/VISME), and supply and spare management tools (NDSS) are operating on NU. With the expected roll-out of the Protected Business Network on NR more COI service element might move towards an NR/NU environment, and therefore also be required in support of NATO led operations. Future issues of the annexes will track those migration steps.

Table E-1: IOP2a Network Transport Service to Interface Mappings

Transport Service	Description	Underlying Transport Service	Link Layer	Physical connector
Data Packet Service	Transport service for packet based data		1000BASE-SX	4ch HMA m
			1000BASE-T	RJ45
Secure NATO Data packet Service	TCE based secure transport service for packet based data		1000BASE-SX	4ch HMA m
			Data Packet Service	
Data QoS Packet Service	Transport service for packet based data with QoS support		1000BASE-SX	4ch HMA m
			1000BASE-T	RJ45
Secure NATO Data QOS packet Service	TCE based secure transport service for packet based data with QoS support	Data QOS Packet Service		
			1000BASE-SX	4ch HMA m
Circuit Switched Transport Service	Circuit Switched Transport Service		PRI	RJ48C
			PRI	BNC 75Ω
			BRI	RJ45
TACOMS Packet Service	Transport service for packet based data using the TACOMS Connection Less (CL) Transport Handling Class (THC)		1000BASE-SX	STRATOS 900
TACOMS CO THC Transport Service	TACOMS Connection Oriented Services (voice telephony and VTC)	TACOMS Packet Service	1000BASE-SX	STRATOS 900

Table E-2: IOP2a COI to Network Transport Service mapping

Product/Application	COI Service	(user) activity	Transport Service	
ICC	Air C2 / TBMD	reporting/tasking	Secure NATO Data Packet Service	
PLATO (ICC@ACC)		situational awareness	Secure NATO Data Packet Service	
LYNC		TMD	Secure NATO Data Packet Service	
OCS	Core FS	Collaboration	Secure NATO Data QoS Packet Service	
AIMS		formal messaging	Secure NATO Data Packet Service	
Core GIS (reduced)		geo services	Secure NATO Data Packet Service	
DHS		Information mgt	Secure NATO Data Packet Service	
WISE		portal services	Secure NATO Data Packet Service	
Tasker Tracker		task mgt	Data Packet Service	
Directory		Directory Services	Secure NATO Data Packet Service	
fax service	Core Service	Fax	Data Packet Service	
E-mail		informal messaging	Circuit Switched Transport Service	
Voice	Core Service	voice	Secure NATO Data Packet Service	
			Secure NATO Data QoS Packet Service	
			Data QoS Packet Service	
			Circuit Switched Transport Service	
VTC		VTC	TACOMS Packet Service	
Spectrum XXI	Environment	frequency management	Secure NATO Data QoS Packet Service	
VISME/HMETOC		meteo	Data Packet Service	
NBCA/HPAC		NBC	Secure NATO Data Packet Service	
ANB	ISR	analysis services	Secure NATO Data Packet Service	
BICES WS		BICES info	Secure NATO Data Packet Service	
FMV DSAR		full motion video	Secure NATO Data Packet Service	
CSD		intel database services	Secure NATO Data Packet Service	
ICMT		intel database services	Secure NATO Data Packet Service	
NITB			Secure NATO Data Packet Service	
JOIIS		reporting	Secure NATO Data Packet Service	
SIGINT/COINS(CTS)			Secure NATO Data Packet Service	
AGS		situational awareness	Secure NATO Data Packet Service	
JTS		joint targeting	Secure NATO Data Packet Service	
TOPFAS	Joint C2	planning and analysis services	Secure NATO Data Packet Service	
JCHAT		reporting/tasking	Secure NATO Data Packet Service	
JOCWATCH			Secure NATO Data Packet Service	
iGeoSit		situational awareness	Secure NATO Data Packet Service	
JCOP			Secure NATO Data Packet Service	
FAST		time sensitive targeting	Secure NATO Data Packet Service	
LC2IS		reporting	Secure NATO Data Packet Service	
LC2IS		situational awareness	Secure NATO Data Packet Service	
CNAFS		Logistics	reporting, requesting, tasking	Secure NATO Data Packet Service
LOGFAS-ADAMS				Secure NATO Data Packet Service
LOGFAS-CORSOM	Secure NATO Data Packet Service			
LOGFAS-EVE	Secure NATO Data Packet Service			
LOGFAS-LogBase	Secure NATO Data Packet Service			
LOGFAS-LOGREP	Secure NATO Data Packet Service			
NDSS	Secure NATO Data Packet Service			
LOGFAS-GEO	Secure NATO Data Packet Service			
LOGFAS-LDM	situational awareness			Secure NATO Data Packet Service
MCCIS	Maritime C2			reporting
LTIS/FFT		situational awareness	Secure NATO Data Packet Service	
NIRIS	TDL	FFT	Secure NATO Data Packet Service	
		live tracks	Secure NATO Data Packet Service	

NATO UNCLASSIFIED

ANNEX E TO
MC 0593

INTENTIONALLY LEFT BLANK

MANDATORY SERVICE BASELINE FOR SHORT TERM REQUIREMENTS

Annex F defines the mandatory service baseline for upcoming NRF preparation and standby period. Selection criteria for each FS was that the version would be mature and supported (training available for NCS, and accessible to NFS) in second quarter of the NRF preparation year, so that NRF certification exercises for in that year can already use the version of that service.

Table F-1 contains the mandatory C2 services required for NRF 2015, assessing their availability in 2Q2014. It lists which C2 service is required in each entity, the security domain it is to be operated, and if the service requires:

- S: both local server installation and work stations,
- C: only a local client installation, reaching into a service provided by a collocated C2 entity (e.g. POCC using server installations in the collocated LCC),
- W: only a web client installation, reaching into a server/service provided elsewhere in the network,
- A: a standalone appliance running on a standard workstation.

Table F-2 contains the mandatory C2 services foreseen for NRF 2016, assessing their availability in 2Q2015. It lists which C2 service is required in each entity, the security domain it is to be operated, and the support the service requires.

Table F-2: Mandatory Deployment of C2 Services and Applications per Deployable C2 Entity for NRF 2016.

Services for NRF 2016 preparation		30/09/2014 08:30		Collocated entities						Collocated entities						Collocated entities						Collocated entities						version										
User Service	Application	JTF HQ		JLSG		JFACC		DACCC		DOB1		LCC		POCC		CBRN		MCC		SOCC		DOB3		NAEW		POD2		FLSB		POD1		DOB2		OLRT				
		NS	MS	NU	NS	MS	NU	NS	MS	NU	NS	MS	NU	NS	MS	NU	NS	MS	NU	NS	MS	NU	NS	MS	NU	NS	MS	NU	NS	MS	NU	NS	MS	NU	NS		MS	NU
Joint C2	JOCWATCH	S		S		S				W		S				C		S		S		W		W		W		W		W		W		V3.0				
	NCOP	S		S		S		W		W		S		W		W		S		S		W		W		W		W		W		W		W		Inc1		
Air / TBMD	JTS	(S)				(S)		(C)				(S)						(S)		(S)															V4.0			
	FAST	(C)		C		(C)		(C)		(C)		(C)						(C)		(C)				(C)		C									V4.0			
	JCHAT server (TCS)	(S)		S		S		S		S		S		S		S		S		S		S		S		S		S		S		S		S		1.1		
	JCHAT client	(C)		C		C		C		C		C		C		C		C		C		C		C		C		C		C		C		C		1.4		
	TOPFAS	(S)		(S)		(S)		(S)		(S)		(S)		(S)		(S)		(S)		(S)		(S)		(S)		(S)		(S)		(S)		(S)		(S)		(S)		5/1.1
	ICC	S		S		S		S		S		S		S		S		S		S		S		S		S		S		S		S		S		V3.0		
Special Ops	AirC2IS	S		S		(S)		(S)		(S)		(S)		(S)		(S)		(S)		(S)		(S)		(S)		(S)		(S)		(S)		(S)		(S)		not avail.		
	PLATO (ICC@ACC)	(S)		(S)		(S)		(S)		(S)		(S)		(S)		(S)		(S)		(S)		(S)		(S)		(S)		(S)		(S)		(S)		(S)		3.2		
Land	SOF C2	(S)																		(S)																not avail.		
	LC2IS	S										S		C		C				S																1.1		
TDL	LTIS/FFT	S										S								S																not avail.		
	NIRIS	(S)		S		S		S		S		S		S		S		S		S		S		S		S		S		S		S		S		3.7		
maritime	MCCIS	(S)		S														(S)		S																6.1		
	LOGFAS-LogBase	(S)		(S)		S		S		S		S		S		S		S		S		S		S		S		S		S		S		S		6.2		
	LOGFAS-ADAMS	(C)		(C)		(C)		(C)		(C)		(C)		(C)		(C)		(C)		(C)		(C)		(C)		(C)		(C)		(C)		(C)		(C)		6.2		
	LOGFAS-CORSOM	(C)		(C)		(C)		(C)		(C)		(C)		(C)		(C)		(C)		(C)		(C)		(C)		(C)		(C)		(C)		(C)		(C)		6.2		
	LOGFAS-EVE	(C)		(C)		(C)		(C)		(C)		(C)		(C)		(C)		(C)		(C)		(C)		(C)		(C)		(C)		(C)		(C)		(C)		6.2		
	LOGFAS-SPM	(C)		(C)		(C)		(C)		(C)		(C)		(C)		(C)		(C)		(C)		(C)		(C)		(C)		(C)		(C)		(C)		(C)		6.2		
	LOGFAS-SDM	(C)		(C)		(C)		(C)		(C)		(C)		(C)		(C)		(C)		(C)		(C)		(C)		(C)		(C)		(C)		(C)		(C)		6.2		
	LOGFAS-GEO	(C)		(C)		(C)		(C)		(C)		(C)		(C)		(C)		(C)		(C)		(C)		(C)		(C)		(C)		(C)		(C)		(C)		6.2		
	LOGFAS-LDM	(C)		(C)		(C)		(C)		(C)		(C)		(C)		(C)		(C)		(C)		(C)		(C)		(C)		(C)		(C)		(C)		(C)		6.2		
	LOGFAS-LOGREP	(C)		(C)		(C)		(C)		(C)		(C)		(C)		(C)		(C)		(C)		(C)		(C)		(C)		(C)		(C)		(C)		(C)		6.2		
Resources	NDSS			X		A		C				C		A		C		A		C		A		C		A		C		A		C		C		23/4.1.1		
	Spectrum XXI		A			A		A		A		A		A		A		A		A		A		A		A		A		A		A		A		4.25		
Functional Services	CNAFS			W		W		W		W		W		W		W		W		W		W		W		W		W		W		W		W		3		
	NBCA																																				11.2	
	CBRN analysis																																				12.1	
	HPAC																																				4.04	
	NAMIS	S		S		W		W		W		W		W		W		W		W		W		W		W		W		W		W		W		W		VISME
	BICES (WS access)	C				C						C						C		C																	3.4	
	NITB	S				W		S		W		W		W		W		W		W		W		W		W		W		W		W		W		8.3.5		
	IOIS	S				W		W		W		W		W		W		W		W		W		W		W		W		W		W		W		8.3.5		
	Analyst Notebook	X		X		X		X		X		X		X		X		X		X		X		X		X		X		X		X		X		X		V8.5
	SIGINT/COINS(CTS)	X		X		X		X		X		X		X		X		X		X		X		X		X		X		X		X		X		X		access only
	INTEL FS																																					not avail.
	Full Motion Video	X				X		X		X		X		X		X		X		X		X		X		X		X		X		X		X		X		not avail.
	ICMT	S				S		S		S		S		S		S		S		S		S		S		S		S		S		S		S		S		not avail.
	CSD					S		S		S		S		S		S		S		S		S		S		S		S		S		S		S		S		not avail.
AGS					S		S		S		S		S		S		S		S		S		S		S		S		S		S		S		S		not avail.	
Core Functional Services	Collaboration	(S)		S		S		S		S		S		S		S		S		S		S		S		S		S		S		S		S		S		
	formal messaging	(C)		C		C		C		C		C		C		C		C		C		C		C		C		C		C		C		C		C		
	information mgt	(S)		S		S		S		S		S		S		S		S		S		S		S		S		S		S		S		S		S		
	task mgt	(S)		S		S		S		S		S		S		S		S		S		S		S		S		S		S		S		S		S		
	REP Services	(S)		S		S		(S)		S		S		S		S		S		S		S		S		S		S		S		S		S		S		1.0.12
Core Services	portal services	(S)		S		S		S		S		S		S		S		S		S		S		S		S		S		S		S		S		S		Incr 2
	voice	(X)		X		(X)		X		(X)		X		(X)		X		(X)		X		(X)		X		(X)		X		(X)		X		(X)		X		
	VTC	(X)		X		(X)		X		(X)		X		(X)		X		(X)		X		(X)		X		(X)		X		(X)		X		(X)		X		
	informal messaging	(X)		X		(X)		X		(X)		X		(X)		X		(X)		X		(X)		X		(X)		X		(X)		X		(X)		X		
	directory services	(X)		X		(X)		X		(X)		X		(X)		X		(X)		X		(X)		X		(X)		X		(X)		X		(X)		X		
	fax	(X)		X		(X)		X		(X)		X		(X)		X		(X)		X		(X)		X		(X)		X		(X)		X		(X)		X		
	fax service	(X)		X		(X)		X		(X)		X		(X)		X		(X)		X		(X)		X		(X)		X		(X)		X		(X)		X		
	File	(X)		X		(X)		X		(X)		X		(X)		X		(X)		X		(X)		X		(X)		X		(X)		X		(X)		X		
Print/Scan	(X)		X		(X)		X		(X)		X		(X)		X		(X)		X		(X)		X		(X)		X		(X)		X		(X)		X			

locally installed capability: S: server & clients C: Client only W: web client X: locally installed core service () Ad hoc provision on a case by case basis A: WS Application only, does not require a server

INTENTIONALLY LEFT BLANK

NATO UNCLASSIFIED

ANNEX G TO
MC 0593

**REQUIREMENTS FOR FEDERATING SERVICE MANAGEMENT & CONTROL IN
NATO LED OPERATIONS**

For further study.

G-1

NATO UNCLASSIFIED

INTENTIONALLY LEFT BLANK

INFORMATION EXCHANGE REQUIREMENTS VERSUS MISSION THREADS

In AJP-6 (Reference K) Information Exchange Requirements (IER) as defined as follows: *Those categories of information that must be exchanged between operational facilities to provide commanders with essential information for decision-making.*

AJP-6 assesses IERs to be pivotal inputs to the CIS planning process to ensure that all relevant C2 services required in support of the mission are identified, and adequate planning and provision of C2 services can be achieved. IERs in form of orders, reports etc. also reflect the exchange of information products in support of the chain of command. Over the last couple of years, a comprehensive list of information exchange requirements in support of NATO led operations have been developed, and have been used as inputs to this document.

For AMN implementation, mission threads have been used to describe requirements for the various mission capabilities required in operations. A mission thread is a descriptive process that entails what actions systems must perform in a specified area of operation and includes the people, hardware, and software that are involved in performing these missions. So rather than looking at an individual information product to be exchanged, it looks at the complete chain of events, activities and related information exchange required to fulfil a certain type of mission in an operation. So a mission thread analysis begins with e.g. an opportunity to detect a threat or element that ought to be attacked and ends with a commander's assessment of damage after an attack.

There is, however, not yet a generic set of mission threads to be supported NATO led joint operations. It was therefore concluded to use and apply the well-defined and comprehensive NRF IER approach as the starting point for the identification and definition of interoperability requirements in MC 0593. It is acknowledged that in addition to fulfilling the IER requested by the C2 relationships adequate processes and procedures must be in place to share the generated information products with a wider community. The organisational element in charge of information and knowledge management shall develop, publish and enforce the necessary processes that enable such information sharing.

INTENTIONALLY LEFT BLANK

c. Option C - Hosted User. A Hosted User is a Mission Network participant that is not able to provide infrastructure and services for self-provisioning. This participant will typically be embedded in an MNE or an MNX per appropriate bi-lateral agreements.

d. Option Z - Other Entities. Participants other than the ones described above enable the exchange of selected information products. These participants are not an integral part of the network, nor are they subject to FMN Framework requirements. Interconnection and information exchanges with these participants will be determined by Option A and Option B participants on a case-by-case basis. An Option Z interconnection typically involves the use of information exchange gateways.

Mission essential services will be defined under authority of FMN Governance in the framework spiral specifications. For Mission Network instances the essential services are selected by the lead operational commander in accordance with mission requirements, considering a basic set of interoperable services.

Mission Network participants with appropriate security mechanisms in place have the possibility to interconnect with their national networks and other trusted networks as well as external information exchange entities. This is possible for Mission Network Elements (Option A) and Mission Network Extensions (Option B). For all participants the external connections are on a mission-to-mission basis and dependent on particular mission constraints.

2. MC 0593 and FMN Considerations

MC 0593 is a concept for C2 on NATO led operations, aligned to currently existing and endorsed NATO policies, and addresses all mission relevant C2 Services and requirements on the operational command level.

MC 0593 covers the technical capability required to meet the C4ISR requirements of a NATO led operation. This ranges from the underlying bearer networks to all Community of Interest services and User applications at multiple security and releasability domains (typically NATO Unclassified, Mission Secret (releasable to Partners), and NATO Secret).

Note: Non-NATO member nations involved in a NATO-led operation may not have access to MC 0593. NATO-led coalition operations that involve NATO and non-NATO Nations may as a matter of course involve collective coordination of mission partner policies to form mission specific policies and C4ISR requirements.

Derived from annual NRF preparation experience, MC 0593:

- a. Provides guidance for the initial phase (deployment +12month) of a NATO-led mission and the NATO minimum C2 and CIS requirements,
- b. Establishes (in addition to Comms and CES) a C2 Service interoperability baseline tailored to the NRF mission spectrum;
 - 1) Allowing NATO and nations to train C2 on a regular basis,

- 2) In accordance with NATO agreed standards, guiding national development/ procurement processes,
- 3) Aiming at C2 interoperability improvement as a continuous guided process, rather than waiting for a specific mission to raise, with the consequence that many decisions have to be done in a rush improved,
- 4) Provides Guidance to National Units involved in NRF.

The NRF technical profile, derived from MC 0593 and NRF experience, will address mostly C2/FS layers of the NATO Interoperability Standards and Profiles, while the FMN technical profile focuses, in its first spiral, on the networking and Core Enterprise Services necessary to establish a trusted and secure federated network relationship/connectivity, as well as compatibility of six core human to human collaboration services, between mission partners for a specific exercise or operation.

The interconnection between national and NATO networks typically requires boundary protection which impedes seamless information sharing as long as all of the individual information elements are not labelled. The lessons learned in Afghanistan is that the current boundary protection devices and the limited implementation of labelling within NATO and national CIS systems impedes seamless information sharing that is critical for the C2 of operations. Whilst FMN aims to implement the security principle of need-to-share at the information level at Milestone 3, it also respects the important of relevance of community of interest separation. It recognises that several steps and a revised security strategy are required to gradually implement this objective.

Implementation of labelling within NATO and national CIS systems utilized within a mission network will further improve the ability to generate, disseminate, exchange and archive information and data critical for command and control of operations among network contributing mission partners within a coalition force.

MC 0593 assumes that national mission networks could in general represent different security and releasability domains. In accordance with current NATO policies the need for boundary protection is maintained when this situation is encountered. This use case is equivalent to FMN's Option Z (external information exchange entity), which also requires appropriate boundary protection.

Employment of the Coalition Interoperability Assurance and Validation (CIAV) capability³⁸ will reduce operational risks and enhance coalition force coherence. As such, CIAV will therefore provide an opportunity to significantly reduce risk for NRF interoperability verification and validation between NATO member and non-NATO member coalition participants.

Figure I-2 shows the mapping of MC 0593 CIS provision principles (see Chapter 3.5 / Figure 3-6) to the FMN capability introduced in Figure I-1. The NATO provided CIS (NATO MNE) establishes:

a multi-node network to deliver the C2 services for the operational command level as per Figure 2-1,

³⁸ It is recognised that NATO, Nations and other organizations are contributing to CIAV.

- a. the capability to connect other Mission Network Elements (2a) and Mission Network Extensions (2b),
- b. the capability to Host Users (HU, to-provision).

It is expected that the framework nations in a NATO led operation will deploy their MNEs and connect them to the NATO MNE via the Interoperability Point 2a. Alternatively, the MNX principle can be applied to connect single/individual nodes.

Note: MC 0593 Chapter 3.5 Figure 3-6 includes national headquarters as interconnection points whereas Figures I-1 and I-2 in this annex refer only to relationships between networks. A NATO HQ or a National HQ may utilize more than one network to support NATO-led coalition operations while respectively supporting simultaneous NATO or national only business as applicable.

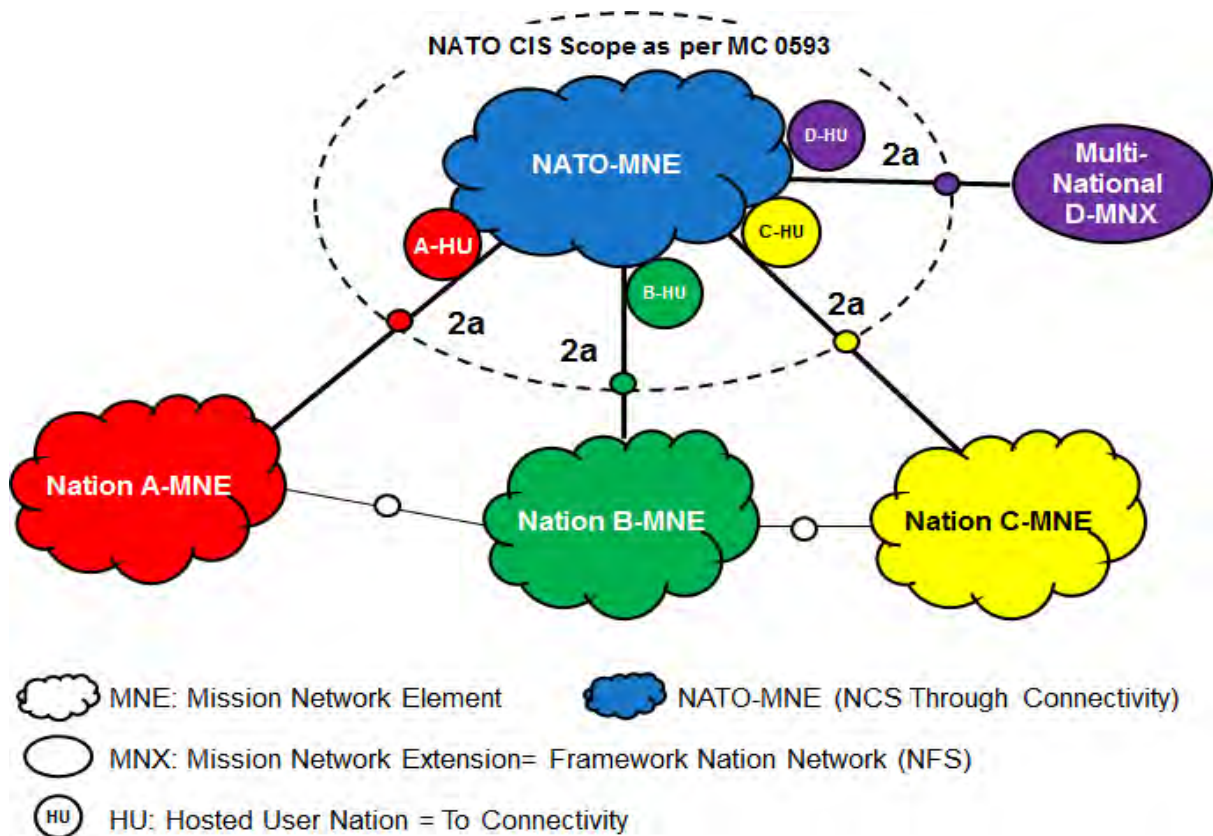

Figure I-2 Mapping of MC 0593 CIS Provision Principles in FMN

REFERENCES

- A. AC/322-N(2013)0107, Way Ahead for MC 0593 'Minimum Level Of Command And Control (C2) Services Capabilities In Support Of Joint NATO Operations In A Land Based Environment', 1 Jul 13
- B. C-M(2011)0022, Political Guidance, 14 Mar 11
- C. MCM-0043-2013, Bi-SC Conceptual Framework for the Alliance Operations, 26 Jul 13
- D. 1500/SHCPPCAM/FCR/281528 and 5000 TSC FRX 0030/TT-7804/Ser:NC 0006 "NATO's Minimum Capability Requirements", 20 Dec 11
- E. AC/322-N(2012)0092-AS1, C3 Classification Taxonomy, 19 Jun 12
- F. Enclosure 1 to AC/322(SC/1-WG/3)N(2008)0008 (INV), Technical Requirements for NATO-to-Nations Service Interoperability in Expeditionary Operations - NC3A Technical Note 1174, 10 Jul 08
- G. SH/CCDJ6/SMFCIS/76/13-302121, 5000 TSC MXX0010/TT-9051/Ser: NR 0039: Implementation of NATO Command and Control Assets, 30 Jun 13
- H. AC/322-WP(2012)0004-Rev1, NATO C3 Interoperability Testing Policy, 22 Jun 12
- I. 5000 TSC FCX 0010/Ser:NU0169, IEG Scenario C requirements, ACT, 5 Apr 12
- J. AC/322-D/0030-REV5, INFOSEC Technical and Implementation Directive for the Interconnection of Communications and Information Systems (CIS), 23 Feb 11
- K. AJP-6 – Allied Joint Doctrine for Communication and Information Systems, 6 Apr 11
- L. APP-15 - NATO Information Exchange Requirement Specification Process (Edition A Version 1), Jun 13
- M. AC/35-D/2004-REV3, Primary Directive on CIS Security, 15 Nov 2013
- N. C-M(2002)49-COR11, Security Within The North Atlantic Treaty Organisation, 28 May 14
- O. MC 0195/9, NATO Minimum Interoperability Fitting Standards for Communications and Information Systems (CIS) Equipment on-board Maritime Platforms (Draft 9), 10 Jun 11
- P. SHPPP/2100/8/04 – 100507 SACEUR's Guidance on the Mission, Role and Organisation of the Operational Liaison and Reconnaissance Team, 26 Apr 04
- Q. MCM-0106-2014(REV1), NATO Federated Mission Networking Implementation Plan, 26 Nov 14

INTENTIONALLY LEFT BLANK



INTERNATIONAL MILITARY STAFF
ETAT-MAJOR MILITAIRE INTERNATIONAL



COMMENT PROCEDURE
EXPIRES AT 1400 HRS,
THU 12 JUL 18

11 June 2018

MSWM-0233-2018

ALL MILITARY REPRESENTATIVES

**MINIMUM LEVEL OF COMMUNICATION AND INFORMATION SYSTEMS
CAPABILITIES AT LAND TACTICAL LEVEL**

References:

- A. IMSM-0302-2015, MC Document Addressing the Minimum Level of Communication and Information Systems Capabilities at Land Tactical Level, 25 Jun 15.
- B. SH/CCDJ6/CISOP PLA/107/18-000324, MC 0640 - "Minimum Level of Communication and Information Systems (CIS) Capabilities at Land Tactical Level" - ACO's Final Draft, 29 May 18.
- C. AC/322(CP/1)WP(2018)0003, Minimum Level of Communication and Information Systems (CIS) Capabilities at Land Tactical Level, 20 Apr 18.

1. At Reference A, ACO was requested to draft MC 0640, "Minimum Level of Communication and Information Systems (CIS) Capabilities at Land Tactical Level", the replacement of NATO Standardization Agreement (STANAG) 5048.
2. ACO submitted draft MC 0640 with Reference B, which was developed in close coordination with the NATO Headquarters Consultation, Command and Control Staff, Joint Force Commands, Allied Land Command, and the NCI Agency.
3. MC 0640 defines the minimum level of CIS connectivity and services required to ensure the effective Command, Control, Communications, Computers, Intelligence, Surveillance and Reconnaissance of tactical level NATO Land Forces. It presents the CIS concept of operations and further explains relationships to the current NATO guidance and standards including Federated Mission Networking (FMN).
4. The development of Draft MC 0640 that has been underway since Sep 15 was finalized after multiple rounds of comments and three workshops with the contribution of custodians, including Graduated Readiness Force Land Components. Meanwhile, ACO regularly updated the MC Working Group (CIS) on the progress and content of the document.



5. The FMN principles defined in the draft were presented to the Consultation, Command and Control Board (C3B) Network and Security Capability Team and FMN Communications Syndicate meeting (15-19 Jan 18). Additionally, a detailed presentation on the same subject was introduced in Think Thank for Information, Decision and Execution Sprint (9-13 Apr 18) under the Mobile Communication and Battle Management Applications track.

6. Furthermore, draft MC 0640 was circulated to the C3B CIS Capability Panel (CaP1) with Reference C. CaP1, as delegated tasking authority of STANAG 5048, provided comments from a technical point of view which were considered during the last workshop (07-09 May 18) and incorporated into the document as necessary.

7. Nations are requested to provide their written comments to the Enclosure, using the MCIS, by 1400 hrs, Thu 12 Jul 18.



Jan Broeks
Lieutenant General, Royal Netherlands Army
Director General
International Military Staff

Enclosure:

1. Draft MC 0640, Minimum Level of Communication and Information Systems (CIS) Capabilities at Land Tactical Level, xx Jun 18.

Copy to: IMS SDL T (LESS MILREPS), IMS/RECORDS.

Action Officer: LtCol Ersoy, NHQC3S (5552) (TTE 181117)

NATO UNCLASSIFIED
DRAFT

ENCLOSURE 1 TO
IMSWM-0233-2018

Draft MC 0640

MINIMUM LEVEL OF COMMUNICATION AND INFORMATION

SYSTEMS (CIS) CAPABILITIES AT LAND TACTICAL LEVEL

NATO UNCLASSIFIED
DRAFT

NATO UNCLASSIFIED
DRAFT

INTENTIONALLY LEFT BLANK

2
DRAFT
NATO UNCLASSIFIED

TABLE OF CONTENTS

<u>CHAPTER ONE - INTRODUCTION</u>	7
Background	7
Aim	8
Scope	8
Applicability	8
Timelines	8
<u>CHAPTER TWO - COMMAND AND CONTROL ENVIRONMENT</u>	11
Political Guidance	11
Implementation Guidance	11
Concepts	12
<u>CHAPTER THREE - GUIDING PRINCIPLES</u>	14
Overview	14
Environment	14
Interoperability Points	15
Federated Mission Networking	16
CIS Security Including Cyber Defence	20
Service Management	23
<u>CHAPTER FOUR – DEVELOPMENT OF INFORMATION EXCHANGE REQUIREMENTS</u>	24
<u>CHAPTER FIVE - C2 SERVICES IMPLEMENTATION</u>	28
Introduction	28
Functional Services/Community of Interest Services Considerations	30
Transmission Services	30
Operational CIS	32
Tactical CIS	32
Services Implementation	34

NATO UNCLASSIFIED
DRAFT

<u>CHAPTER SIX – RESULTING SERVICE REQUIREMENTS PER TYPE OF C2 ENTITY</u>	42
VJTF(L) BDE C2	42
Intelligence	45
Fire Support	46
Logistics	49
Air Support	50
Medical	52
<u>CHAPTER SEVEN - ENABLING SERVICES</u>	55
Spectrum Management	55

ANNEXES

A.	Abbreviations	A-1
B.	Definitions	B-1
C.	Information Exchange Requirement (IER) Specifications	C-1
D.	Connectivity Diagrams for C2 Services Implementation	D-1
E.	Services Requirements per Type of C2 Entity Development	E-1
F.	Federated Mission Networking (FMN)	F-1
G.	Potential Solutions for Interoperability Points (IOP)	G-1
H.	References	H-1

NATO UNCLASSIFIED
DRAFT

INTENTIONALLY LEFT BLANK

6
DRAFT
NATO UNCLASSIFIED

CHAPTER ONE: INTRODUCTION

BACKGROUND

1. The NATO Strategic Concept lays out NATO's vision for the next decade: "An Alliance able to defend its members against the full range of threats, capable of managing the most challenging crises and better able to work with other organisations and Nations to promote international stability. NATO will be more agile, capable and efficient, and will continue to serve as an essential instrument of peace".
2. The provision of effective Communication and Information Systems (CIS) that is robust, flexible and interoperable within and between the NATO Command Structure (NCS) and the NATO Force Structure (NFS), Non-NATO Nations (NNN) and other International Organisations (IOs) directly contributes in ensuring that NATO's Level of Ambition (LoA) and vision is achievable.
3. The current threats, both conventional and hybrid, faced by those Nations which deploy in support of a NATO mission are both symmetric and asymmetric. They cover multi dimensions and fronts, requiring forces to be ready to act, using spearhead forces that are required to deploy rapidly over a large geographical area providing deterrence, assurance, defence and when required offensive action in order to eliminate the threat.
4. The provision of CIS throughout the Command and Control (C2) structure is required to support and not hinder the commander in achieving the mission. The deployed networks of today are complex, requiring multiple functional services and domains, provided by NATO Nations to be interoperable and interact with each other to provide the commander the intelligence he/she requires in order to make relevant decisions.
5. Inside the Federation Mission Networking (FMN) Framework and Spiral implementation process, the FMN Spiral Specifications Vision and rolling FMN Spiral Specifications Roadmap (up to 10 years out) (Reference A) describes collective level of ambition envisaged in a realistic evolution of land tactical networking in the next 3-10 years.
6. MC 0593/1 is a framework document for Joint C2 in NATO led operations at strategic and operational level (Reference B). MC 0640 as service specific Military Committee (MC) document will cover the Land tactical level replacing the former STANAG 5048.

DRAFT

AIM

7. To define the minimum level of CIS connectivity and services required to ensure effective Command and Control, Communications, Computers, Intelligence, Surveillance and Reconnaissance (C4ISR) of tactical NATO Land Forces.

SCOPE. This publication:

8. Provides the minimum scale of CIS at Land tactical level, spanning from Headquarters Land Command and below, but with particular focus on Corps and below. In order to provide supporting information and reference, this document, where necessary, will provide direct extracts from extant NATO documentation. The principle of MC 0640 should be applied when NATO Land forces are deployed on any NATO led type of mission to include when a Graduated Readiness Force Land Component (GRF(L)) assumes the role of Joint Headquarters (JHQ) A/B and is conducting a Land orientated mission as part of the Joint operation. Those missions are articulated according to the NATO Defence Planning Process (NDPP).

9. Includes, as examples, NATO CIS standards and tables containing Information Exchange Requirements (IERs), connectivity diagrams for C2 services implementation and services requirements per type of C2 entity for NATO-led Land based operations, detailing both the deployment of Very High Readiness Joint Task Force (VJTF) Brigade (BDE) within a VJTF (Land (L)) and the deployment of Land Component Command (LCC). This publication complements the work conducted in MC 0593/1 defining the required networks, systems and services in the Land domain down to Company (COY) level and derived from NRF orientated exercises. It is written to assist Nations in assessing their CIS capabilities to:

- a. Fulfil mission aims by exercising C2 over assigned NATO Land forces,
- b. Achieve the maximum degree of interoperability,
- c. Describe available and future solutions for multinational Land forces interoperability to support seamless information exchange.

APPLICABILITY

10. The targeted audience are J6/G6/S6 staff who are responsible for CIS planning in the land domain for NATO-led operations, NATO Response Force (NRF), VJTF(L), GRF(L)s etc. This document also offers a baseline for CIS capability.

TIMELINES

11. Near Term. For the next 6 years, the document :

- a. Explains the operational context and includes the expected operational dynamics (e.g. whether assets are expected to operate on the move or at the halt, and over what sort of geographic areas),

DRAFT

- b. Provides a definitive list of the minimum required CIS services to support C4ISR at the tactical level, and the required coverage of these services with respect to the expected Order of Battle (ORBAT) and C2 structures. The list would need to reflect what is pragmatically achievable by Nations and NATO, and could draw on current exercise experiences and the capabilities provided in NRF and VJTF rotations. The list should include at least the human-to-human (H2H) services (noting possible bandwidth constraints) plus essential core and functional services,
- c. Specifies the minimum level of connectivity,
- d. Specifies the security operating levels (e.g. mission secret and/ or restricted),
- e. Specifies responsibilities (higher to lower, left to right etc.).

12. Long term. For the next 10 years (in accordance with the FMN roadmap) the document:

a. Sets out any known changes to the operational context and operational capabilities. However, the default assumption would be that this will remain as it is now.

b. The following four phases describe the realistic evolution of land tactical networking:

(1) Interconnection of tactical networks and Mission Network Elements (MNEs) of different participants in a standardised way. For this purpose the MNE providers will have to provide standardised IP-over-Radio Gateways and respective communications equipment. Tactical units can then connect to these gateways/base stations. This interconnection may require some manual technical reconfiguration and/or exchange the system assets (e.g. loading of a wave-form, exchange of crypto equipment). Participants that provide both MNEs and their own tactical networks may have proprietary interconnections for which it is also planned to have Information Exchange Gateway (IEGs) (between Operational and Tactical Networks) if they are operating on different security levels (dependency on content/message labelling),

(2) As a second step, the interconnection of tactical networks and MNEs of different participants will take place in a standardised way without the need to exchange system assets, but might still require some manual reconfiguration. More services will be enabled for x-domain exchange,

(3) As a third step, the interconnection of tactical networks and MNEs of different participants will happen automatically based on pre-

DRAFT

determined configuration details. In parallel, tactical units will be able to federate their tactical networks with each other,

(4) In the fourth phase, the interconnection of tactical networks and MNEs of different participants will be achieved automatically so that tactical units can “roam” between base stations of different MNE providers.

CHAPTER TWO: C2 ENVIRONMENT

POLITICAL GUIDANCE

13. Political Guidance (PG) 2015 (Reference C) provides the overall aims and objectives to be met by the Allies within the framework of Alliance defence planning. To that extent, the LoA established in the PG is represented as the forces and capabilities, including non-military capabilities required to cope with several Major Joint Operation (MJOs) and multiple Small Joint Operation (SJOs) concurrently or Major Joint Operation Plus (MJO+).

14. Inside this LoA, GRF(L) HQs and packaging of combat forces, Combat Support (CS) and Combat Service Support (CSS) will be established in common with the support of Nations to participate in NATO led operations requiring diverse functional military capabilities.

15. As immediate response capability, Land forces will be part of NATO's collective rapid-response capability participating in NRF at appropriate readiness. When they deploy as part of the Follow on Force (FoF) structure, Land forces will deliver the capability to operate in scale from small through to larger than MJO and be sustained by means of force rotations.

16. This MC takes into account that very few, if any, missions will be conducted using purely land forces; therefore, consideration needs to be given to interoperability and CIS provision responsibilities within the Joint Domain.

IMPLEMENTATION GUIDANCE:

17. This document applies the tactical projection of principles defined for strategic and operational levels. It contemplates the information derived from the NDPP cycle. Furthermore, by following the MC 0593/1 guidance, the introduced Minimum Capability Requirements (MCR) (Reference D) are also considered with an intention of those requirements be embodied within the next versions of this document.

18. Following the baseline of MC 0593/1, the key factors that derive the size and the character of the C2 Services for the Land forces in a NATO led operation are outlined as follows:

- a. Military structure and C2 templates,
- b. Technology integration and evolution towards federation,
- c. The Consultation, Command and Control (C3) Taxonomy (Reference E),

- d. Information Assurance considerations (IA).

CONCEPTS

19. Concepts covered in this document are:

- a. C3 Taxonomy of Services,
- b. Operational CIS (OPCIS) domain as the network deployed from Corps down to BDE,
- c. Tactical CIS (TACCIS) domain as the network from BDE down to the lowest deployed level of land C2,
- d. Mission Networking (MN) as mechanism for that the Commander is able to command, but applying the FMN principles when technical capabilities will allow,
- e. Interoperability Point (IOP),
- f. Information Exchange Gateway (IEG),
- g. CIS Security/Cyber Defense as essential to Land CIS.

20. This MC 0640 document reflects the structures and relationship between IOPs and introduces solutions to interoperability issues emerged from different types of radio equipment and crypto but retaining the general principles of coalition connectivity Higher to Lower, Supported to Supporting, Left to Right.

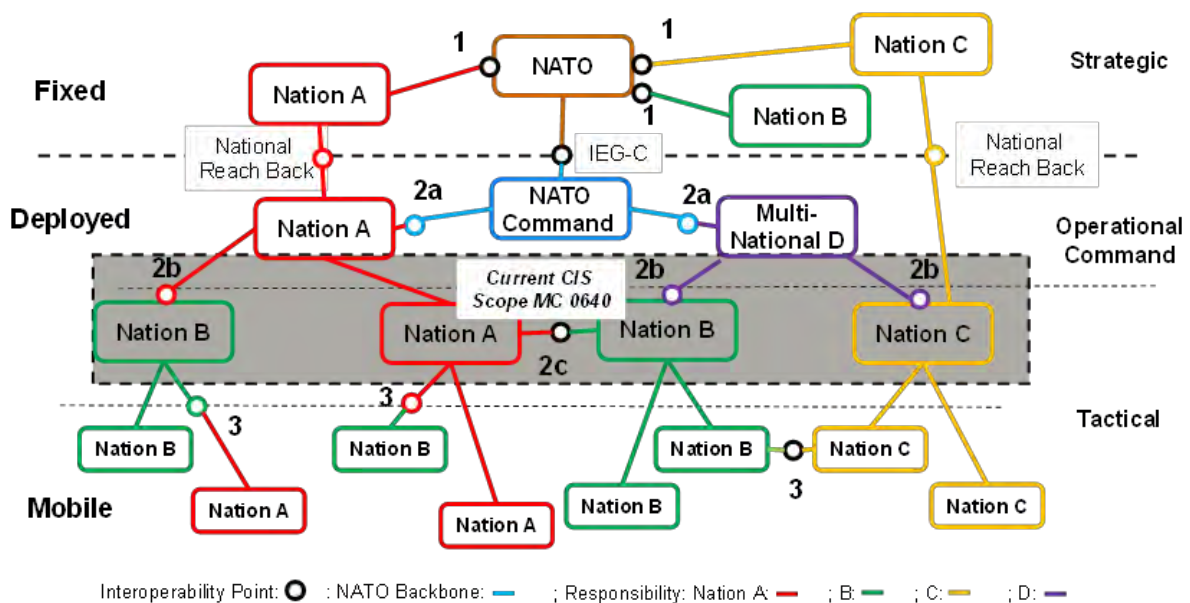

Figure 2-1: Scope of This Edition of MC 0640

DRAFT

21. MC 0593/1 introduces the interoperability layers as depicted in Figure 2-1; 1 (for strategic), 2 (for the operational command level and non-mobile tactical level) and 3 for the tactical mobile environment, and details the interoperability requirements for layer 2a. This first edition of MC 0640 will address the layers 2b and 2c, in the scope of this document also referred to as OPCIS. Furthermore, first high level principles for the adjacent tactical mobile element at layer 3 are provided. The term TACCIS is introduced to describe that mobile tactical layer. Figure 2-1 depicts the scope of the interoperability requirements developed under MC 0640, using the layer diagram introduced in MC 0593/1.

22. Interoperability Point 2b is on the higher tactical level between two elements on different C2 hierarchy levels, while IOP 2c is between C2 entities at the same hierarchical C2 level. MC 0593/1 does not further classify the tactical mobile layer 3, but defers the discussion of this topic to MC 0640.

CHAPTER THREE: GUIDING PRINCIPLES**OVERVIEW**

23. CIS networks, systems and services that are deployed by Land forces shall be systematically interoperable with lateral and immediate subordinate formations.

24. At all levels of the Land domain, networks, systems and services should conform to the relevant extant standards as defined in the NATO Interoperability Standards and Profiles (NISP)¹ Allied Data Processing Publication 34 (ADatP-34) to enhance interoperability and support seamless information exchange. If the current fielded systems do not conform to the applicable standards then once the equipment is replaced or upgraded the Nations should ensure that the new CIS equipment conforms to the standards applicable at time of fielding the new capability.

ENVIRONMENT

25. At the tactical level, network-enabled capabilities enhance forward command (AJP-3-2, Reference F). Through all phases of a NATO deployment, users need to access the necessary services and the information product in relation to their specific function or area of expertise. This includes the production of plans during the Crisis Response Planning (CRP) phase, to the issuing of orders or control measures during the execution. Once the plan has been formulated then the requirement exists for land C2 entities to have the necessary networks configured in order to disseminate plans and orders down to the lowest level of (multi-) national Land C2 entity.

26. The services used, at the static peacetime location, during the CRP phase, should have the same functionality as those services used when deployed into the Joint Operational Area (JOA). The ability to share, disseminate and consume information with different entities located in different geographical locations and different security domains, is a requirement. This includes those C2 entities that remain static in their peacetime location for the duration of a deployment. The Mission Anchor Function (MAF) provides this capability, particularly during the initial transitional phase of a deployment, transitioning from planning and preparation to deployment.

27. NATO FMN principles shall be applied and followed for the implementation and operation of Land tactical CIS services. Annex F introduces the FMN principles including the FMN framework, the role of the Service Management Authority (SMA) and the related concept of mission instantiation. For the Land tactical domain the MC 0640 defines the initial FMN reach and service coverage. It is expected that future versions of MC 0640, aligned with the increasing technical and operational scope of FMN, will increase the proliferation of FMN principles to lower tactical

¹ The NISP also contains the FMN Spiral 2 Profiles.

DRAFT

echelons, and continuously increase the amount and maturity of implemented FMN services.

28. The provision of CIS must conform to NATO Security Policy (Reference G) and National Security Regulations.

29. Federation of services as defined by the FMN framework shall be applied to Land tactical CIS to the maximum extent possible. MC 0640 mandates the application of FMN principles, and implementation of FMN compliant services down to and at BDE level. Federation down to and at BG level is encouraged. If the mission requires certain services that are not yet covered by the FMN Spiral Specification valid at the time of deployment, the Mission Service Management authority shall define the implementation details for those services.

30. Until FMN Spiral Specifications defined IOP3² is fully implemented by NATO, traditional CIS provision principles shall apply for force echelons at BDE level and below.

INTEROPERABILITY POINTS

31. Interoperability Points. Seamless information sharing into the mission network and across domains is required in order to influence the commander's decision making process. The IER analysis has determined that in many instances information flows cross various network and security domain boundaries. The achievement of interoperability can be categorised into two main areas:

- a. Standards based interoperability,
- b. Asset based interoperability.

32. Standards Based Interoperability. Standards based interoperability describes the concept of achieving interoperability by implementing the same technical and procedural standards on different systems, and thereby achieving interoperability that is based on the standards selected to implement services. The federation principles set forth in FMN are encouraging/enforcing standards based interoperability. At interoperability points 2a, 2b and 2c standards based interoperability shall be applied, at a minimum in step with the incrementally increasing interoperability scope defined in the FMN spiral specification.

33. Asset Based Interoperability. Where services are not yet standardised, asset based interoperability can be applied to the Land tactical environment. For the OPCIS layer, this could be the sharing of the same application or appliance, and that the mobile layer (until FMN Spiral Specifications provide full interoperability IOP3) it might even be required to exchange radios or network nodes to achieve interoperability.

² IOP 3 is connecting mobile tactical endpoints via a radio, through a radio interface, that requires a common waveform and is supported by both radios to achieve interoperability.

The assets that are shared can range e.g. from a single interoperable radio that is provided to a tactical unit, to the provision of assets and support staff providing a range of services.

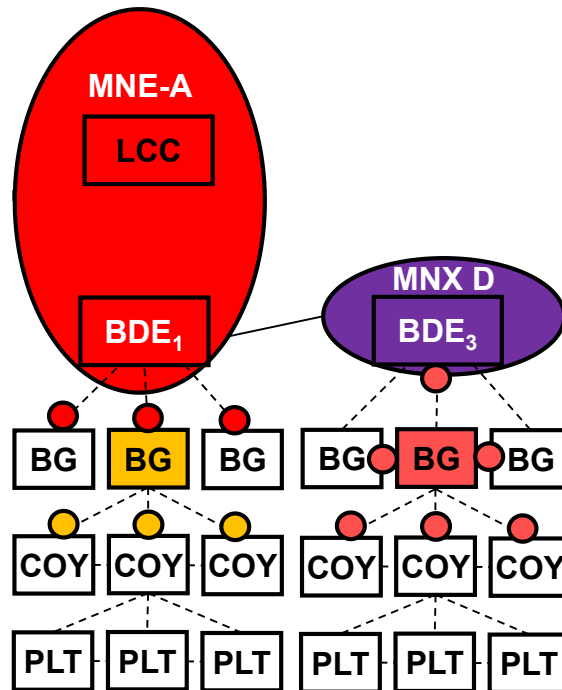

Figure 3-3: Examples for Asset Based Interoperability below BDE Level

On the left hand side of Figure 3-3, asset based interoperability examples are shown where the higher C2 element provides assets to the lower elements (BDE down to Battlegroup (BG), and BG down to Company (COY)). The right hand side depicts asset based interoperability through a voluntary contribution on BG level, reach up, down, left and right.

FEDERATION MISSION NETWORKING

34. FMN Operational Requirements.

a. The FMN Concept sets the following objectives to drive the operational requirements for a Mission Network:

- (1) Seamless H2H Communication across the force,
- (2) A single view of the battlespace across the Mission Network,
- (3) Timely provision of a Mission Network,
- (4) Provision of consistent, accurate and reliable mission data,
- (5) Community of Interest (COI) capabilities that align with the mission requirements,

DRAFT

(6) Well trained staff that can support an effective decision cycle and take full advantage of the systems provided.

b. FMN will use Mission Threads to define and organise operational processes and technical support services required for a coalition mission. “A Mission Thread is an operationally driven, technically supported description of the end-to-end set of activities required to execute a mission or mission task”. While the concept of Mission Threads is already used by Nations and in operations, the Mission Thread Implementation Process in NATO has not been finalised yet, so current MC 0640 work will be solely IER based. The NATO Mission Thread Capstone Concept (Reference H) was approved and the progress on the Action Plan for NATO Mission Thread implementation will inform future issues of MC 0640 on which NATO Reference Mission Threads to consider in the land tactical environment.

35. FMN Considerations for MC 0640.

a. NATO has committed to apply the federation principle to NRF and future NATO led operations, therefore all command and force elements shall adhere to FMN principles and provide the required services in a FMN compliant manner. This section therefore derives the high-level requirements for Land Tactical CIS interoperability that are induced by FMN.

b. As introduced above, the FMN ambition is for a seamless end-to-end services implementation across all command hierarchies and tactical echelons, so federation should be applied down to the lowest tactical level. However, technical capabilities available today put a limitation towards the achievable level of federation at the tactical level, as FMN services assume native IP networking services that require a networking infrastructure with an acceptable throughput.

c. Independent from a federated or traditional CIS service provision approach, the FMN operational requirements objectives 1 and 2 (introduced above) address the complete force and the mission battlespace, and are therefore applicable to MC 0640.

d. This edition of MC 0640 adheres to the following FMN compliance:

(1) Seamless H2H communication is required across all tactical and mission network elements,

(2) Tactical networks need to be able to seamlessly consume the single view of the battlespace produced in the MN,

(3) Tactical networks need to be able to seamlessly contribute/update elements of the battlespace view,

(4) Today, proliferation of federation principles to the tactical level is constraint by technical limitations. For recent STEADFAST COBALT

(STCO) exercise series, NRF BDEs participated as FMN MNEs and planning for current STCO indicates similar ambition from the upcoming NRF BDEs. MC 0640 therefore assumes that FMN principles can be applied to achieve interoperability down to and at BDE level. For the time being, interoperability below BG level can follow legacy land tactical CIS provision principles,

(5) Mission Threads will not be considered for this MC 0640 edition.

36. FMN Service Provision Principles.

a. MC 0593/1 introduces the use of the federation principle to provide mission critical C2 services to the operational command level. Experiences gained from previous NRF preparation cycles proves that such federation principle can be successfully applied to the operational command level of the NRF.

b. MC 0640 therefore assumes that in a Land tactical environment federation of services can be applied down to and including the BDE level, and that traditional CIS provision following the high-to-low and left-to-right principle will only be applied below BDE level. Figure 3-1 depicts the proposed approach.

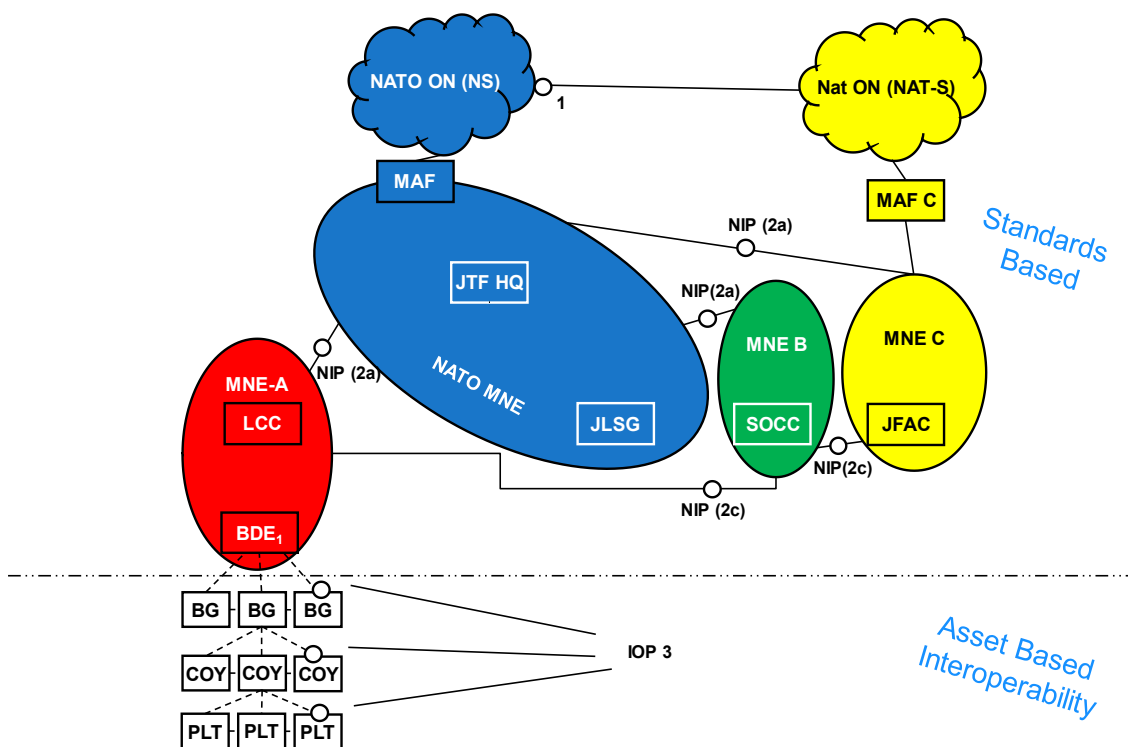

Figure 3-1: CIS Provision Principles-1 for NRF

c. The scenario depicted in Figure 3-1 assumes that Joint Task Force (JTF) HQ and Joint Logistics Support Group (JLSG) are drawn from the NCS, and therefore part of the NATO provided MNE. The NATO provided MNE is

connected via the MAF to the NATO Operational NATO Secret (NS) network (referred to as Operational Network as per Interface Termination Module (ITM)). The other Component Command (CC) framework Nations are providing National MNE as part of their LCC, Special Operations Component Command (SOCC) and Joint Force Air Component Command (JFAC) contribution. Network Interconnection Points (NIPs) form the interconnection points between MNEs. Note that in addition to NATO, Nation C has also decided to create her National MAF, and nationally provided reachback into Nation C static network. Federation principles apply above the dotted line, while below traditional High-to-Low and Left-to-Right provision principles may be applied.

d. Following the same provision principle, figure 3-2 depicts the evolution of the NRF scenario from figure 3-1 into a (Division size) NRF scenario after deployment of two additional BDEs from the Initial Follow-on Forces Group (IFFG) pool.

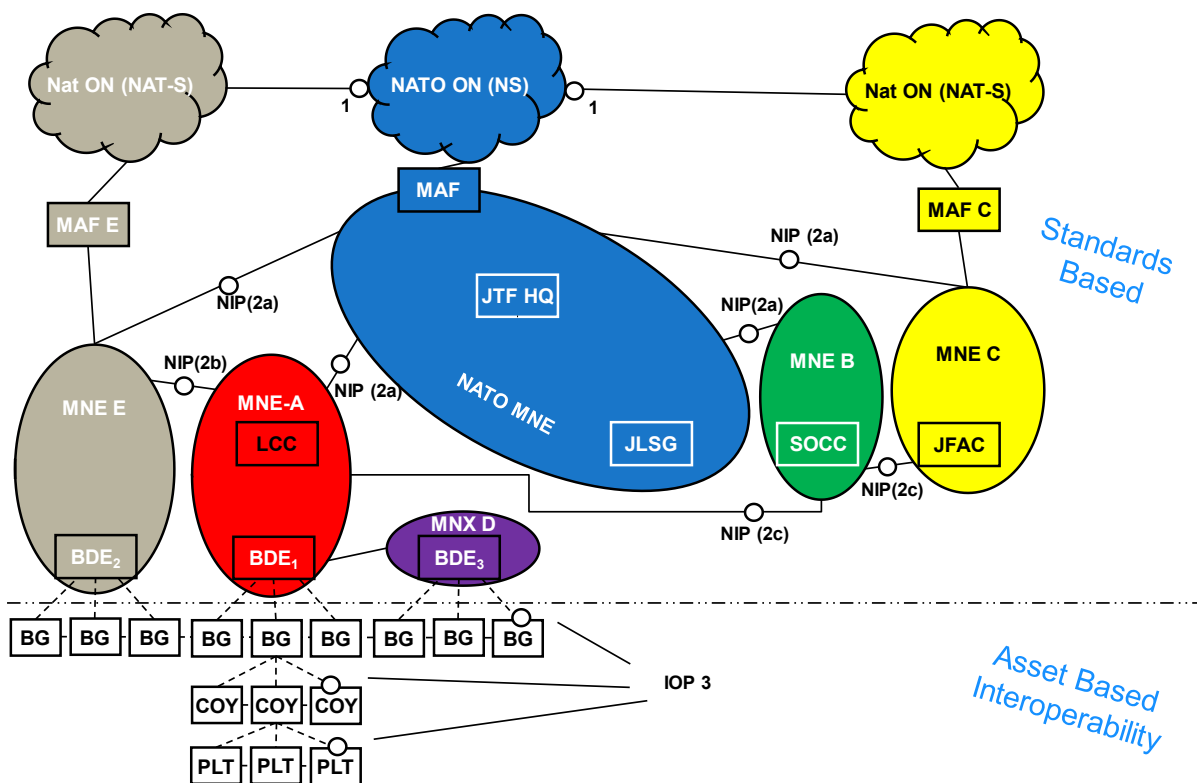

Figure 3-2 CIS Provision Principles-2 for NRF

e. In figure 3-2 the BDE size Land force is augmented with additional two BDEs, Nation D provides C2 services for its BDE using the MNX model, while Nation E deploys a full MNE infrastructure.

f. More FMN specific considerations and requirements are detailed in Annex F.

DRAFT**CIS SECURITY INCLUDING CYBER DEFENCE**

37. Introduction. CIS Security including Cyber Defence supporting Land Forces CIS is an integral aspect of the wider security arrangements of a Land Forces supported mission. CIS Security encompasses both the management and technical activities necessary to achieve an appropriate level of protection for the mission CIS handling NATO/ Mission information and the information processed within this CIS.

38. CIS Security requirements and effects shall be reviewed during the CIS life-cycle through an iterative approach that perfects security measures whether they be of a procedural or technical nature. This process is initiated and overseen by the mission CIS security accreditation process.

39. Mission CIS Security Accreditation.

a. In missions where CIS networks are interconnected and services are shared, CIS security and Cyber Defence risks are also shared by each mission participant, and the weakest element in the federation defines the strength of the overall coalition.

b. It is therefore pivotal that common policies and standards are applied across all Nations and Forces that contribute to the mission, and that any deviation from those policies and standards are communicated to all mission partners, and that deviations can only be accepted on the basis of a common risk assessment, and acceptance of the residual risk by all mission partners.

c. The FMN framework sets forth the principles of such a mission wide CIS security accreditation process that involved all mission partners, and the Multinational CIS Security Management Authority (MCSMA) looks after all CIS security related aspects of the FMN Spiral specifications. When a mission is instantiated, a Mission Security Accreditation board (MSAB) is created, that uses the MCSMA produced inputs as a basis for mission specific CIS Security related work. The MSAB is chaired by the affiliate that executes the mission command, and all national CIS security accreditation entities have a seat in the mission accreditation board.

d. Tactical units operating at OPCIS level, if not yet representing in the MSAB due to national engagement at operational command level, therefore have to comply to the above principles and contribute to the MSAB.

e. The level of involvement of units only operating at the mobile tactical layers to the overall CIS Security accreditation and management process is for further study.

f. Responsibilities. CIS Security requires the following CIS Security Authorities to be established within Land Forces supporting CIS entities:

- (1) CIS Operational Authority (CISOA),

DRAFT

- (2) CIS Planning and Implementation Authority (CISPIA),
- (3) CIS Provider (CISP),
- (4) Security Management Staff,
- (5) Security Accreditation Authority (SAA).

g. It should be noted that although CISOA and CISPIA play major roles in the mission CIS definition/ planning/ design and implementation, the other authorities' involvement are necessary at the earliest possible stage to cover the entire lifecycle of the Mission CIS.

h. The Land Forces supporting CIS Security framework shall ensure that the setup and security accreditation of a mission network can be achieved in a timely manner while meeting the security needs of the mission. For each instantiation of a mission network be this a corps or BDE, a separate Security Accreditation Entity (SAE) shall be appointed and duly recognized within the mission IER specification. A mission-specific Security Accreditation Board will likely be consisting of entities sourced from the forces that make up the mission even including entities from NATO Partner Nations and other non-NATO Nations.

i. A mission network is a federation of cooperating and interoperating CIS entities, and therefore requires all participants in this CIS federation to contribute to its security. All mission network participants are responsible for the CIS Security of their assets, including cyber defence during the operation of the CIS. Only through a combined effort can the overall CIS Security of the mission network be achieved. Trust must be established between the mission participants, and includes agreement on procedures for accreditation, operation of CIS Security during the lifetime of any mission network, and the management of identities, credentials, and privileges for personnel. During the operation of a CIS, preventive measures must be ensured on a day-to-day basis including system updates/patching, identity management, and key management. In addition, continuous monitoring for malicious cyber activity is necessary to respond to and recover from cyber incidents.

j. Identity and Access management. With a focus on controlled information sharing, it is necessary to determine the identity of an information or Information and Communications Technology (ICT) service originator or requester, and this with a reasonable level of confidence. This is done through authentication of the users and coherence in identity, credential and access management. In a federated mission setting, this means that each participant will do identity management for their mission contribution (e.g. Log on to a CIS) according to the agreed security level, and will exchange the necessary information so that other mission participants can find out who the requester is and be assured that this information is correct.

DRAFT

40. Security Domains. Define all domains starting from NS to NATO Unclass (NU) with the security minimum requirements for every one in part. Proposals: FMN Mission Secret, OPCIS Mission Secret and TACCIS Mission Restricted, etc.

a. The Minimum Military Requirement (MMR) for a unit participating at OPCIS level is to support CIS Security at (Mission) Secret level.

b. The MMR for a unit participating at TACCIS level is to support CIS Security at (Mission) Restricted level.

c. The transition from Mission Secret to Mission restricted is foreseen at the BDE level.

d. Units may apply hyperencryption for services that require protection above the MMR level outline above.

e. It is noted that the FMN ambitious is to be flexible in the security classification of the main operational domain. However, this version of MC 0640 considers Mission Secret as the minimum military requirement for the main operational mission domain. Scenarios, and derived CIS requirements for a main operational domain on confidential or restricted level are for further study.

41. Information Assurance (IA). In order to achieve the security objectives of confidentiality, integrity, availability, authentication and non-repudiation for classified information handled in tactical CIS, a balanced set of security measures (physical, document, industrial, personnel, information and CIS Security) shall be implemented to create a secure environment in which information can be protected over its mission lifecycle.

42. Crypto. Increasing interoperability of crypto devices is one of the aims of NATO's Crypto Modernisation Programme and the related research areas. The current situation on crypto applied in the Land domain in Tactical environment is described in NATO Cryptographic Baseline and Reference Architecture Perspectives - Revision 1 (Reference I). In addition to the Land scenario architectural baseline the reference document also outlines the strategy towards increasing levels of crypto interoperability in an evolutionary manner. Due to the security classification of Reference J the reader can refer to it for further detail.

43. CIS Security including Cyber Defence.

a. NFS and National Defence Forces (NDF) assigned to a NATO military operation, and their supporting or embedded CIS structures shall have the necessary CIS Security including cyber defence arrangements implemented. Military Cyber Defence arrangements shall be aligned to the Military Cyber Defence Concept (MC 0571/1) (Reference J) and amplifying SACEUR direction and guidance for Cyber Defence. C2 arrangements of SACEUR over NATO Communications and Information Agency (NCIA) capabilities are only

DRAFT

binding upon common-funded CIS and interconnectivity points of NCS to NFS CIS.

b. As defined in the Reference J, NATO will use NATO Computer Incident Response Capability (NCIRC) services to support detection of cyber incidents and ensuring mitigating activity. All NATO military entities are responsible to report any suspicious cyber related activity through their chain of command as well as to NCIRC in accordance with their Standard Operating Procedures (SOPs). Troop Contributing Nations (TCNs) are responsible to implement appropriate cyber defence in accordance with NATO's minimum requirements for CIS Security including Cyber Defence (Reference K).

SERVICE MANAGEMENT

44. Service Management including Visibility of Service status, is key information for the operational commander. Therefore, each network element or network extension provider and the tactical units shall be equipped with the means to enable:

- a. Assessing service status,
- b. Reporting on their CIS Services status,
- c. Sharing service status,
- d. Managing and maintaining services,
- e. Coordinated efforts on continuous service improvements.

45. The Mission Network Operations Centre (MNOC) will provide a network operation status and CIS advice to the mission commander. MNOC has Technical Authority and therefore subordinate unit network elements or extensions will provide a daily CIS status report. This policy applies to NCS/NFS down to BDE level.

46. Similar visibility, reporting and incident information exchange is required for Cyber Defence and CIS Security. Attached to the MNOC, there shall therefore be a Mission Security Operations Centre (SOC), providing mission wide CD/CS visibility to the mission commander and coordinating and facilitating CD/CS related reporting, incident information exchange, coordination of incident responses, etc.

47. If required, selected MNOC and SOC elements can be forward deployed, but some main functions, due to technical complexity and Subject Matter Expert (SME) involvement, are expected to always stay in the MAF.

CHAPTER FOUR: DEVELOPMENT OF INFORMATION EXCHANGE REQUIREMENTS

48. AJP-6 (Reference L) states: Information Exchange Requirements (IER) define the need for information exchange between two or more parties that support a given process. IERs describe the source and destination of the information flow, the content and usually a number of other information flow characteristics. IERs are pivotal inputs to the CIS planning process. They ensure all relevant C2 services required in support of the mission are identified, and adequate planning and provision of C2 services can be achieved. The NATO process for specifying IERs, including managing their configuration, is described in APP-15 Edition A, Version 2 (Reference M).

49. MC 0593/1 (Reference B) contains representative IERs for NATO led Joint Land based operations using the SJO-2 mission template and have been derived from NRF orientated exercises (e.g. STEADFAST COBALT, TRIDENT series). In addition the IERs contained within MC 0593/1 are mainly focused on the Strategic and Operational levels.

50. Scope. The IERs within MC 0640 will complement the work conducted in MC 0593/1, defining the IERs required in the Land Tactical environment, down to COY level³. The IERs contained within MC 0640 have been determined in close coordination with the GRF(L)s, including those held at readiness in support of the (NRF) BDEs held at high readiness in support of the VJTF(L).

51. Comprehensive IER schematics and tables detailing the dissemination and consumption of information products contained within Annex C MC 0640 are:

- a. VJTF (L) BDE C2,
- b. VJTF (L) & MJO+ Intelligence,
- c. VJTF (L) & MJO+ Fire Support,
- d. VJTF (L) & MJO+ Close Air Support,
- e. VJTF (L) & MJO+ Logistics,
- f. VJTF (L) & MJO+ Medical.

52. The following VJTF (L) & MJO+ IERs will follow in later updates to MC 0640:

- a. Air Defence,

³ IERs for NATO led Land based operations, detailing as examples both the deployment of VJTF (L) BDE within a VJTF (L) scenario and the deployment of a LCC with subordinate Corps and multiple BDEs deployed in a MJO+.

DRAFT

- b. Military Engineering,
- c. Military Police,
- d. Civil and Military Cooperation (CIMIC).

53. The IERs within this document will primarily focus on the required C2 services and the H2H Services:

- a. Informal Messaging (Email),
- b. Text-Based Collaboration (Chat),
- c. Audio-Based Collaboration (Voice),
- d. Video-Based Collaboration (Video Teleconferencing),
- e. Friendly Force tracking (FFT),
- f. Local Position Reporting.

54. IER Maintenance. The IERs contained within this document are to be used during any land deployment in support of NATO led exercises and operations. During all phases of the deployment the contents of the IERs are to be analysed in order to determine their relevancy and currency. IER observations and proposals post such activities are to be provided to SHAPE J6 and HQ LANDCOM whereby they will be taken into consideration and when authorized they will be contained in future editions of MC 0640.

55. Information Exchange Environment.

a. Considerations.

(1) When operating in a Land centric environment not all information product flows are limited to, and contained within, the Land dimension.

(2) NATO Land Forces will be required to operate in a multi-dimensional and complex environment with the production and dissemination of information products between Land, Air and Maritime forces, Cyberspace personnel, civilian agencies and non-NATO entities.

(3) The requirement exists for information products, as required, to cross boundaries from one security domain to another with a different classification (e.g. Mission Secret to NATO Secret or Mission Secret to Mission Restricted).

DRAFT

(4) The information flow is made more complex with C2 entities being situated at different locations at different phases of a deployment. For example, a GRF-L Initial Command or Coordination Element may initially be deployed forward into the JOA operating on a Mission Secret domain, whilst the Main Headquarters is located in its static peace time location operating on a NS Domain – the requirement exists to exchange information effectively. In a NATO mission context, the assigned mission anchor function will implement that information exchange.

(5) The deployed force will be multinational in nature, therefore, increasing the complexity of the interoperability solution, particularly when using Line of Sight (LOS) narrow bandwidth wireless transmission services (tactical radios) below BDE.

b. The Requirement. Whatever the complexity of the operational environment, a requirement exists to seamlessly pass and consume information products to each level of command/entity wherever they are located and whatever security domain, each is operating on.

c. Information Flow. The command of Land forces is characterised by the need for concerted action across a complex set of inter-related headquarters, many of which are physically distant from each other (AJP-3-2, Reference F). During all phases of a deployment there is a vast array of diverse information product that is transmitted between multiple entities. With product information contributing and influencing the wider common operational picture, information is required to be collated and disseminated through multiple layers of the C2 structure (eg, track services). The passage of such information requires systems, networks and services that are compatible and where necessary have IOP and IEG deployed, thus, enabling an accurate and timely recognised view of the battlespace to be made available.

56. Types/Categories of information. The following types and categories of information exchanged within the Land domain:

a. H2H services:

(1) Voice,

(2) Email,

(3) Chat.

b. Battlespace information:

(1) Common Operational Picture (COP), Recognized Ground, Maritime and Air Pictures (RGP), (RMP), (RAP) etc.,

(2) Orders and reports,

DRAFT

- (3) Track/Position information,
- (4) Geospatial information,
- (5) Localized operational picture,
- (6) Reports.

Note that there shall be regional and local views of the RGP that shall allow creation of local blue force awareness for tactical units that do not have access to mission secret networks.

CHAPTER 5: C2 SERVICES IMPLEMENTATION

INTRODUCTION

57. A service is a capability provided to benefit or support communities of users (AJP-6, Reference L). Services are classified and described using the C3 Taxonomy. The C3 Taxonomy provides a tool and common language to NATO’s C3 capabilities by connecting NATO’s strategic concept and political guidance through the levels of ambition expressed in the NATO Defence Planning Process to traditional CIS architecture and design constructs.

58. The C3 Taxonomy introduces Community of Interest (COI) Services as depicted in Figure 5-1.

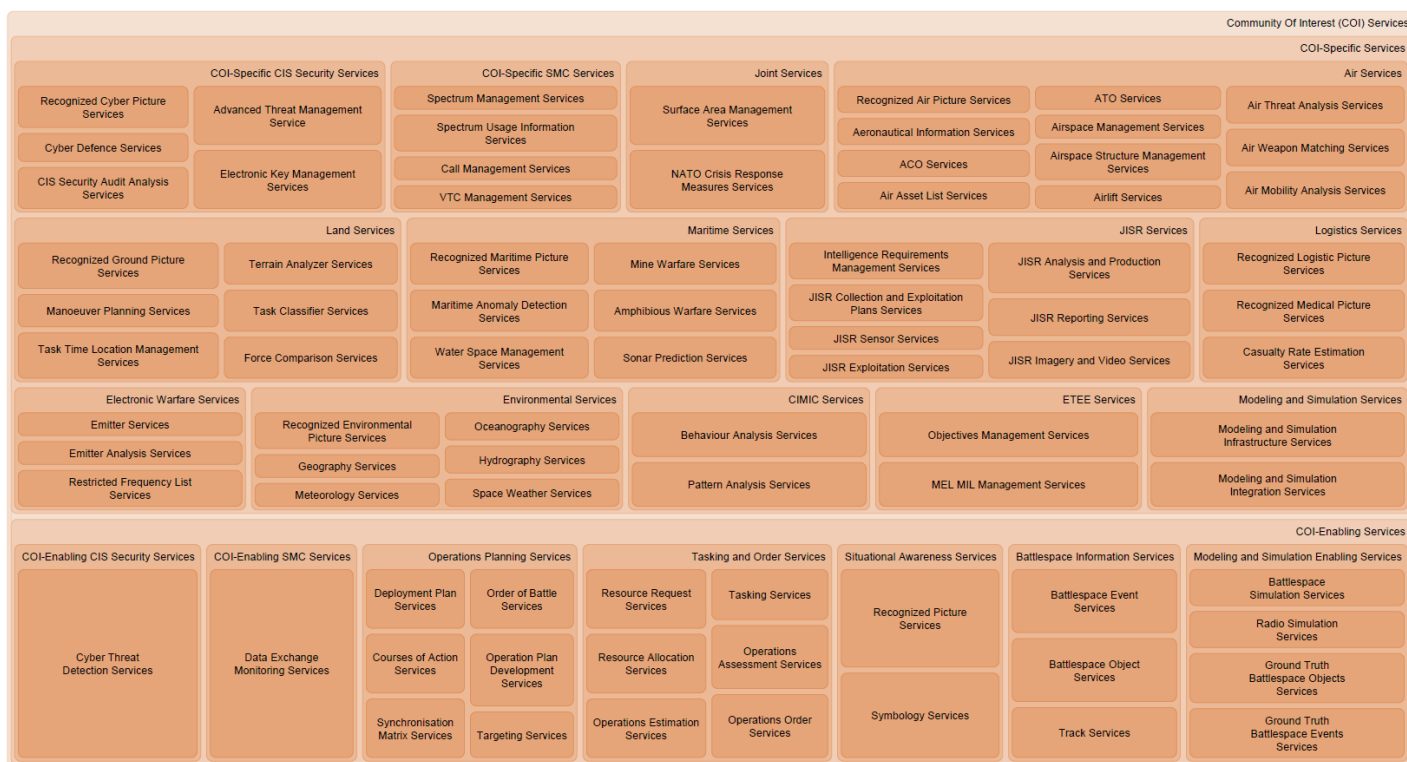

Figure 5-1: C3 Taxonomy COI Services

59. COI Services rely on Core Enterprise Services and Communication Services for end to end information exchange. MC 0640 will focus primarily on COI-Specific and COI-Enabling Services, Transmission Services, Unified Communication and Collaboration Services relevant on tactical level:

- a. Informal Messaging (email),

- b. Text Based Collaboration (chat),
- c. Audio Based Collaboration (voice),
- d. Video Based Collaboration (VTC)⁴,
- e. Friendly Force tracking (FFT),
- f. Local Position Reporting.

60. Figures 5-2 provides illustrative detail in relation to the Unified Communication and Collaboration Services as depicted by the C3 Taxonomy, with the H2H Services highlighted.

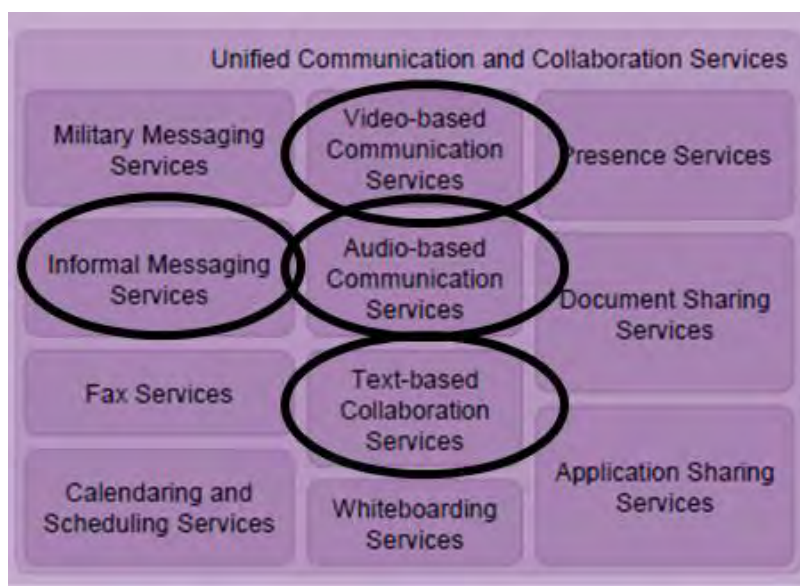

Figure 5-2: H2H Services

61. Figure 5-3 provides illustrative detail in relation to Transmission Services as depicted by the C3 Taxonomy.



Figure 5-3: Transmission Services

⁴ Need for VTC services in only for the higher tactical levels were connectivity can be consider adequate to support VTC.

DRAFT

FUNCTIONAL SERVICES / COMMUNITY OF INTEREST SERVICES CONSIDERATIONS

62. A specific service maybe required at the lower tactical level (BG and below), whilst the same service type may also be required at the higher tactical level (Corps and above). (E.g. COP⁵). Bandwidth might be constrained the closer a C2 entity is to the Front Line of Own Troops (FLOT), however a requirement still exists for that particular entity to have access to the determined services. The way in which the required services are delivered and the Graphical User Interface (GUI) presented to a user will differ depending on where the user is located in the land C2 chain. For example, the higher up the Land C2 chain an entity resides, the GUI will be more sophisticated and provide additional interactive functionality. The lower down the Land C2 chain the C2 entity resides the required service presentation will be more templated and text based. However, the overriding factor is; wherever a Land C2 entity resides in the chain of command the same core functionality must be available.

63. Due to the requirement for lower tactical forces to be able to manoeuvre at short notice and at irregular intervals, whilst consuming and disseminating services on the move, it is anticipated that as a direct result of this mobility requirement, the amount of available bandwidth is likely to decrease in direct proportion to the manoeuvrability of a Land asset. A basic graphical representation can be found at Figure 5–6.

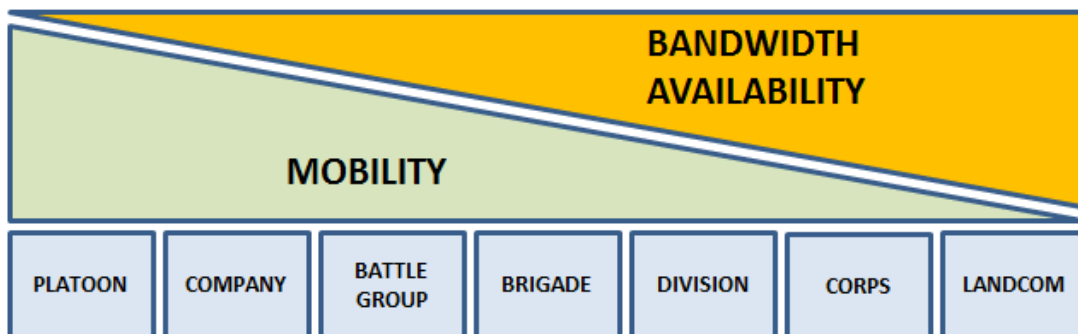

Figure 5–6: Mobility versus Bandwidth Availability

TRANSMISSION SERVICES

64. Transmission Services. Different types of transmission services will be used throughout the Land domain, dependant on the range, terrain, bandwidth requirement and if the need exists to utilise services whilst on the move. As general rule, the higher up the C2 chain the Land entity resides, the more bandwidth is available and the ability to operate on the move is not required as routine. Figure 5-7 provides an example of the types of transmission services employed in relation to the level of Land C2. Currently NATO is working on Mobile Wideband Waveforms to support future operations.

⁵ The COP is a continually updated picture of the battlespace. The COP reflects information about own forces, adversary forces, neutral forces, the environment, and collection asset status (AJP-3-2).

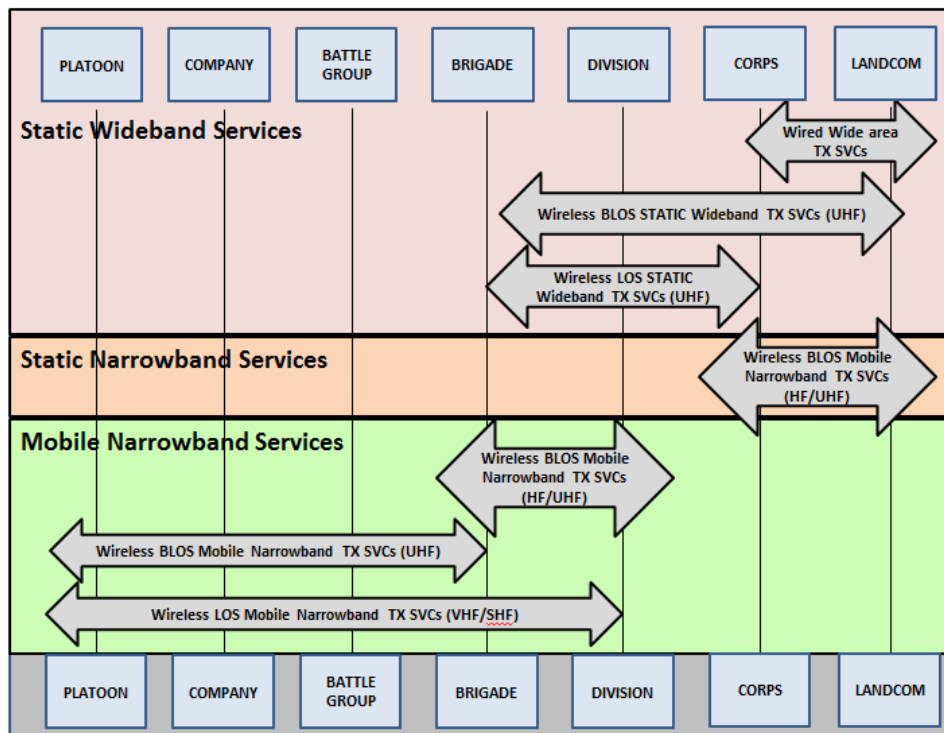

Figure 5-7: Types of Transmission Services in Relation to Land C2

65. The type of transmission service at division and below will depend on the size of the allocated Area of Responsibility (AOR) and the type of terrain transmitting over. The size of the allocated AOR will also depend on the nature of the mission. For example if the mission is to defend or delay then the allocated AOR will be larger than if the mission was offensive. Figure 5 -8 provides an illustrative example of the AOR size for a defensive mission. The example might differ slightly nation to nation but presents an indication for the types of distances the deployed transmission services will be required to operate over.

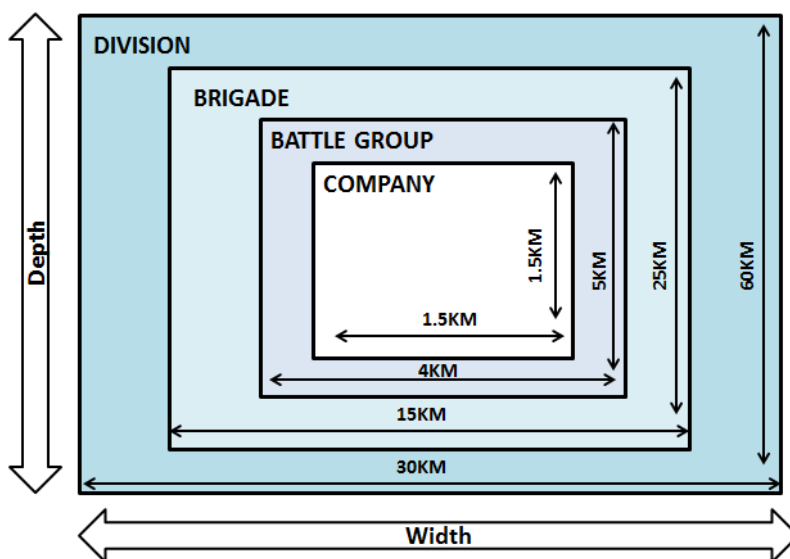

Figure 5-8: Example of AOR Size for a Defensive Mission

OPERATIONAL CIS

66. OPCIS. The OPCIS domain is the network(s) deployed from Corps down to and including BDE. OPCIS shall provide all services as required for each C2 entity at OPCIS level. For those services contained in the applicable FMN Spiral specification, federation principles shall apply, and interoperability shall be provided by adhering to the same standards and service specifications. For those service that are required, but are not yet standardised, asset shared interoperability shall be applied as long as necessary. With each new spiral more of the required services will become federated until finally all OPCIS relevant services will be fully interoperable and federated. Figure 5-9 provides an illustrative example of the transition from OPCIS federated/non-federated to full federation, using Spiral 1 (implemented), Spiral 2 (in implementation), Spiral 3 (under development).

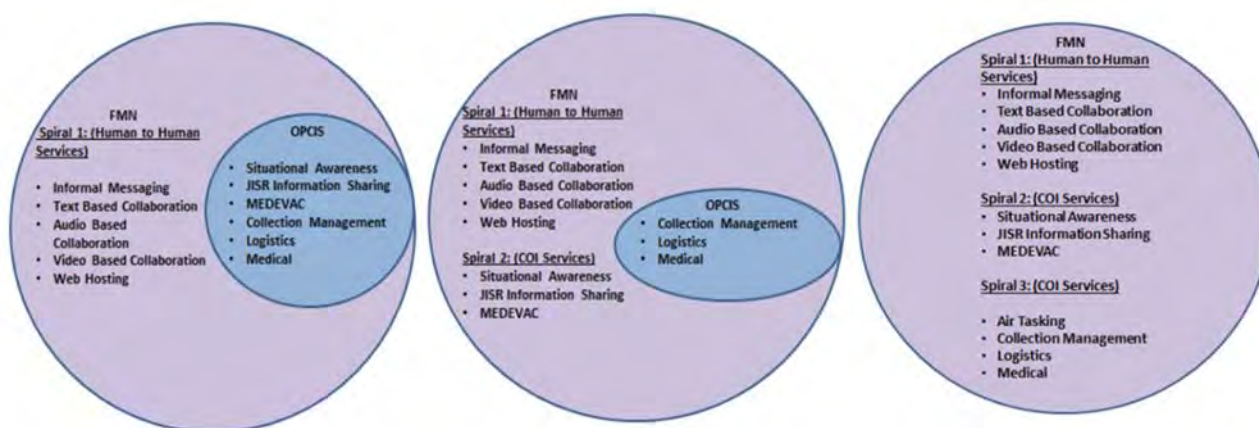

Figure 5-9: OPCIS to FMN Transition

67. Transmission Services (OPCIS Domain). The transmission services bearers utilised within the OPCIS domain are Beyond Line of Sight (BLOS) wideband military satellite bearers, complimented by wired transmission services (commercial leased line) and LOS Wideband and Beyond LOS troposcatter wireless Ultra High Frequency (UHF) and Super High Frequency (SHF) bearers interconnecting C2 entities. There is no requirement for these transmission bearers to operate on the move. Within the OPCIS domain wireless BLOS narrowband transmission bearers High Frequency (HF) and Ultra High Frequency (UHF) are used as an alternate means of communications. There is no requirement for these transmission bearers to operate on the move.

TACTICAL CIS

68. TACCIS. The TACCIS domain are the network(s) deployed from BDE (if deployed) down to the lowest deployed level of land C2. The TACCIS domain provides the required networks in order to deliver H2H and C2 services. At present the required services delivered at the lower tactical level will not be federated. Asset based interoperability principles will have to be applied to achieve the interoperability level required. When required and as determined by the IER analysis TACCIS must have the ability to seamlessly consume and disseminate products with those

NATO UNCLASSIFIED
DRAFT

federated services located in the FMN/OPCIS domain. As a minimum the following services are required to access the mission network:

- a. H2H:
 - (1) Voice,
 - (2) Email,
 - (3) Chat.

- b. Possess the ability to consume:
 - (1) COP information (relevant to allocated physical AOR boundary),
 - (2) Orders and Reports.

- c. Possess the ability to produce/disseminate:
 - (1) Track/position information,
 - (2) Geospatial information,
 - (3) Localized operational picture,
 - (4) Reports.

Figure 5-10 depicts the relationship between TACCIS and OPCIS FMN transition.

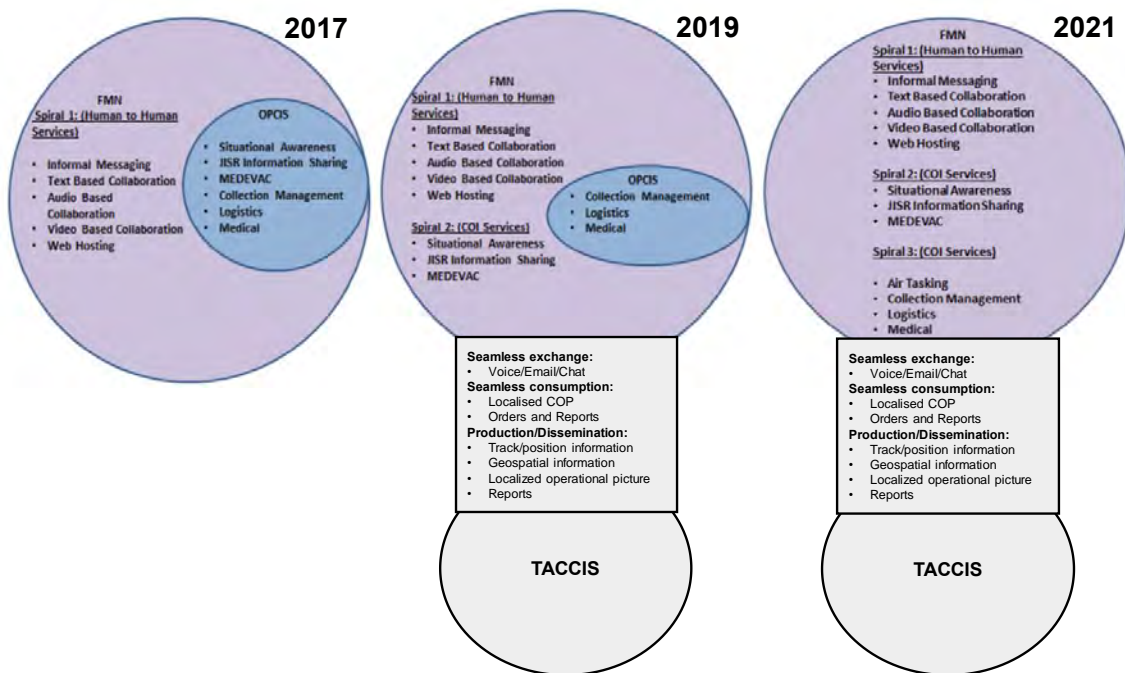

Figure 5-10: OPCIS to FMN Transition; Relationship to TACCIS.

DRAFT**SERVICES IMPLEMENTATION**

69. Headquarters Land Command. Those Land C2 elements that come from within the NATO Command Structure (NCS) will have all of their service requirements met by NATO common funded Deployable CIS (DCIS) capabilities known as Deployable Points of Presence (DPoP). The common funded DPoPs will adhere to each of the FMN spiral specifications as they are released. DPoPs will provide an Interface with Nations Module (INM) to enable NATO nations to interconnect and access the NATO core network. The following provides outline details in relation to the implementation of federated services as stated and extracted from the FMN Spiral 2 service instructions (Appendix 5 to Reference N):

a. Audio-based Communication Services (Voice). Voice, either classified or unclassified, is a core network service on the MN. The MN Voice Service must ensure that all voice devices can establish a connection with any other voice device on the MN with the same security classification:

(1) Unclassified (referred to as VoIP) shall be used for unclassified voice services only. This option allows interconnection with public voice networks and therefore allows communication with organizations outside the FMN and outside the military domain.

(2) Classified (referred to as Voice over Secure IP - VoSIP) relies on communications security through the network using commercial grade telephones. This option allows for classified communications but is constrained within the security domain and/or community of interest.

(3) Call Manager (CM). Acts as registrar for the end user terminals, and provides all directories and value added services end users are using within the Mission Network.

(4) Gateway (GW). Acts as voice routing element within Mission Network. For each MN Provider there can be one or several Call Managers and Gateways.

(5) Numbering Plan. The network Numbering Plan is based on STANAG 4705 (Reference O); it standardizes the dial plan criteria. The subscriber number should be taken from STANAG 5046 (The NATO deducible Directory) (Reference P) and the network numbering plan based on STANAG 4705.

b. Informal Messaging (email). Email across the mission network is established using Simple Mail Transfer Protocol (SMTP). With an intermeshed network of interconnected mail servers. MNX participants without an own mail server use the mail server of a MNE for transporting e-mails of their associated e-mail domain. Each network entity is responsible for ensuring security with respect to virus and malware scanning and classified

DRAFT

emails are only relayed to networks and users that have the appropriate level of classification.

c. Text Based Collaboration (Chat). Chat is centred on time critical operations in order to minimize reaction time. It allows users to communicate in near real-time or semi-synchronously via text messages, whether between two users directly, within ad hoc groups, or within persistent chat rooms. Chat is based on the Extensible Messaging and Presence Protocol (XMPP), with servers forming the backbone of the XMPP network, by the means of server to server connections within the mission network. A server provides a point to which clients may connect in order to exchange/impart information.

d. Video Based Collaboration Services. The MN Video Based Collaboration Service must ensure that all video devices can establish a connection with any other voice device on the MN with the same security classification. MNEs that have gatekeepers (GK) and conference bridges, in the guise of Multipoint Control Units (MCU) can federate with each other. The Mission Network VTC service is based on a full IP network and supports point-to-point and multi-point, room-based and desktop conferencing. Each MNE has at least one MCU and Gatekeeper. The VTC MN supports three types of sessions/connections:

- (1) Peer-to-Peer,
- (2) Peer-to-MCU,
- (3) MCU-to-MCU.

e. Consume federated Data Links Services - Recognized Air Picture (RAP), Recognized Maritime Picture (RMP), Recognized Ground Picture (RGP).

f. Provide and consume federated FFT Services, federated Geospatial Information Services, federated Joint C3 Information Exchange Services (MIP).

g. Federated Service Management and Control.

h. Non NATO Entities. The requirement exists for Audio Based Collaboration (voice), Informal Messaging (email) and portal collaboration to be established to Non NATO Entities.

Other Services not covered by the applicable FMN Spiral specifications are also needed, detailed service requirements per tactical C2 entity are covered in Chapter 6.

70. Corps/Division/BDE (including appropriate level entities).

a. C2 Services. The required C2 services as articulated during the IER process are likely to be delivered over the same IP networks to enable H2H services. Server to server connections will be established between national OPCIS domains and the NATO core network.

b. Non NATO Entities. The requirement exists for Audio Based Collaboration (voice), Informal Messaging (email) and portal collaboration to be established between C2 entities spanning Corps to BDE to Non NATO Entities.

c. Legacy Systems. It is acknowledged that within their own respective OPCIS domain, nations may still utilise legacy systems, protocols and switching, in order to provide the required C2 services, and, on occasion voice services. Where legacy systems are employed to deliver services and the requirement exists for services to be disseminated to neighbouring and higher entities, IOPs and IEGs are to be established to enable bi-directional information flow.

71. Division & BDE/Division/BDE Level Entities. Division and BDE will employ wireless LOS and narrowband BLOS bearers in order to consume and disseminate services to the lower tactical level. These transmission services belong to the OPCIS domain. As illustrated in Figure 5-10 the OPCIS to TACCIS seam will typically reside at BDE. The 'seam' is the point at which the transmission services transition from static wideband services (OPCIS) to mobile wireless narrowband services (TACCIS).

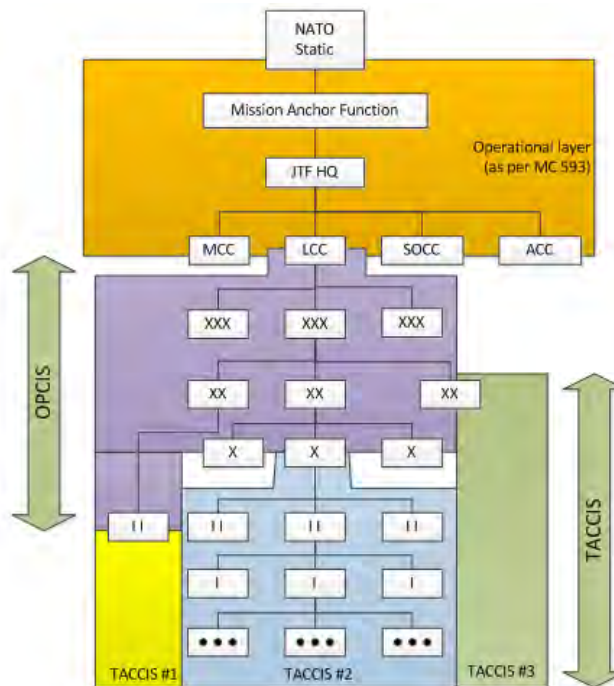

Figure 5-10: OPCIS to TACCIS 'Seam' within a MJO+ Scenario

DRAFT

a. TACCIS narrowband wireless services are required during movement between locations, e.g., when a HQ is relocated the Commander will need access to services whilst on the move between headquarters in order to maintain situational awareness and enact C2.

b. The following provides outline details in relation to the implementation of H2H services from Division down to subordinate C2 entities:

(1) Audio-based Communication Services (Voice). Voice is predominately achieved by using LOS and BLOS Wireless narrowband transmission services. Tactical radios operate on radio networks which are established by function (C2, fire support, logistics, etc). Information by voice is passed mainly by broadcasting simplex voice to a user designated by a unique identifier (callsign). When utilising broadcast voice all users on the wireless network, and within range, will be able to also receive the information being transmitted. It is acknowledged that some nations may also deploy wireless systems that exclude other members of the same net from listening, by employing digital wireless point to multipoint addressing schemes. The requirement exists to conduct audio based collaboration (Voice) at least one level up and one level down the C2 chain and horizontally to neighbouring forces.

(2) Informal Messaging (email). Email maybe enabled between C2 entities spanning Division to BG by establishing a high capacity data radio network, providing self-managing IP based backbone capability, with SMTP mail servers enabling email. If nations do not possess an IP enabled network within the TACCIS domain then C2 information can be consumed and disseminated implementing the standard file transfer protocols that conform to extant STANAGs (e.g., STANAG 5066, Reference Q).

(3) Text Based Collaboration (Chat). Tactical chat IP based software applications can provide the ability to exchange text messages and files among fielded and networked data terminals. Tactical chat can be point-to-point or broadcast among members of an IP subnetwork. Messages can be exchanged between wired (e.g. Ethernet LAN amongst the local HQ) and wireless (to a neighbouring or higher C2 entity). Modern radio terminals can also possess a tactical chat function directly from the tactical radio or via a small data entry device connected to the tactical radio.

(4) Video Based Collaboration Services. The IER studies that have been conducted for MC 0640, have concluded that Video Based Collaboration Services below BDE is not a mandatory requirement at the present time.

DRAFTc. C2 Services.

(1) Friendly Force Tracking Information. Modern tactical radios that will deploy in support of a NATO mission will have the ability, using a global positioning system, to automatically broadcast details of their respective location, known as FFT. Associated software applications are required in order to collate this location information from multinational entities/tactical radios deployed in the respective AOR and display them on a GUI. The GUI will provide commanders and forces with location and basic force information. In addition to this localized collation and displaying FFT information, the requirement exists to collate, disseminate and consume FFT information to neighbouring and superior C2 entities to enable an accurate COP to be produced and regularly updated.

(2) Battlefield Information Applications. At Division/BDE down to BG entities, C2 and function specific services will be provided by the deployment of tailored Battlefield Information Applications (BIAs) hosted over the IP based backbone infrastructure. The BIAs will present the staff users with the necessary services to enable their core function to be performed and the necessary orders and reports/returns to be consumed and disseminated. BIAs may also contain APP-11 (Reference R) templates to enable the dissemination of message text formatted standardized templated messages to be disseminated between entities.

72. Battlegroup (BG).

a. The transmission bearer services at this level of land C2 used to consume and disseminate services to the higher command, lateral and subordination formations are mobile BLOS and LOS wireless narrowband bearers. These transmission services belong to the TACCIS domain. The LOS and BLOS wireless narrowband service capability will be provided by tactical radios. LOS tactical radios in the Very High Frequency (VHF) and UHF frequency band will be the predominant bearers at this level of C2, with BLOS being used if the terrain is challenging and the distance is beyond the normal operating range of the LOS systems. A BG needs to be agile, flexible and mobile; therefore H2H and essential C2/Situational Awareness services need to be available whilst on the move.

b. The following provides outline details in relation to the implementation of H2H services from BG down to COY level entities:

(1) Audio-based Communication Services (Voice). Voice is achieved using LOS and BLOS Wireless narrowband transmission services. Tactical radios operate on radio networks which are established by function (C2, recce, intelligence, logistics, etc.). Information by voice is passed mainly by broadcast simplex voice to a

DRAFT

user designated by a unique identifier (callsign). The requirement exists to conduct audio based collaboration (Voice) at least one level up and one level down the C2 chain and horizontally to neighbouring forces.

(2) Informal Messaging (email). As a matter of routine, email services will not be available from BG level entities down to Company (COY).

(3) Text Based Collaboration (Chat). Modern tactical radio terminals possess a tactical chat function directly from the radio or via a small data entry device connected to the tactical radio. From BG down to COY level entities, Chat will most likely be facilitated using these methods.

(4) Video Based Collaboration Services. The IER analysis process has determined that VTC is not required from BG down to COY level entities.

c. C2 Services. C2 information can be consumed and disseminated implementing the standard file transfer protocols that conform to extant NATO standards (e.g., STANAG 5066, Reference Q). Templated messages using Message Text Format (MTF) conforming to APP11/AdatP3 standards can be consumed and disseminated using standard file transfer protocols.

73. COY.

a. The transmission services bearer at this level of land C2 that are used to consume and disseminate services to the higher command, lateral and subordination formations are BLOS and LOS wireless narrowband bearers. These transmission services belong to the TACCIS domain. The LOS and BLOS wireless narrowband service capability will be provided by tactical radios. LOS tactical radios in the VHF and UHF frequency band will be the predominant bearers at this level of C2, with BLOS being used if the terrain is challenging and the distance is beyond the normal operating range of the LOS systems. Entities deployed at the COY level of C2 need to be agile, flexible and mobile; therefore H2H and essential C2/situational services need to be available whilst on the move:

(1) Audio-based Communication Services (Voice). Voice is achieved using LOS and BLOS Wireless narrowband transmission services. Tactical radios operate on radio networks which are established by function (C2, recce, intelligence, logistics, etc.). Information by voice is passed by broadcast simplex voice to a user designated by a unique identifier (callsign). The requirement exists to conduct audio based collaboration (Voice) at least one level up and one level down the C2 chain and horizontally to neighbouring forces.

DRAFT

(2) Ground to Air. It is at COY and below that land entities will be required to communicate directly with air entities whilst on task. This is required in order to coordinate/conduct liaison, deconfliction in relation to numerous tasks, to include, but not restricted to: medical evacuation and during Close Air Support (CAS) missions. This function will be forefilled using ground to air Wireless LOS mobile narrowband transmission services that operate in the UHF and VHF frequency bands.

(3) Informal Messaging (email). As a matter of routine, email services will not be available at COY level of C2.

(4) Text Based Collaboration (Chat). Modern tactical radio terminals possess a tactical chat function directly from the radio or via a small data entry device connected to the tactical radio. Chat at this level of C2 entity will be facilitated using the aforementioned mediums.

(5) Video Based Collaboration Services. Due to the bandwidth constraints at COY level of C2, VTC services will generally not be available.

b. C2 Services. C2 information can be consumed and disseminated implementing the standard file transfer protocols that conform to extant STANAGs (eg, STANAG 5066, Reference Q). Templated messages using Message Text Format (MTF) conforming to APP11/AdatP3 standards can be consumed and disseminated using standard file transfer protocols. At COY and below, standard file transfer protocols will be implemented using a Data Entry Device (DED) that connects directly to the tactical radio.

c. Operational Plans/Orders. At the lower tactical level of COY and below the use of verbal orders will be regularly utilised to deliver operational plans, orders and situational updates. The verbal orders will be conducted either over secure tactical voice radio networks or by commanders visiting the higher command location to physically receive the verbal delivery.

d. Friendly Force Tracking Information. Tactical radios that will be deployed in support of entities residing at COY and below are to possess the ability to, automatically broadcast details of their respective location, using a global positioning system, to their immediate higher command entity.

74. Liaison Officers. There is significant requirement for liaison at component level: with the JTF-HQ; with other components; with subordinate formations or national contingents; with the host nation; and with civilian agencies and organizations, most on a reciprocal basis (AJP-3-2, Reference F). A Liaison Officer (LO) whenever deployed will require access to the necessary services in order to provide an effective liaison function. The deployment of an Air Liaison Element (ALE) to the LCC and the Ground Liaison Element (GLE) to the Air Component Command (ACC) level of C2 is one such example. The Air Support (AS) IER

DRAFT

analysis captures the H2H and C2 services for the ALE's deployed at the different levels of Land C2 (Air Support enabling services and service provision are introduced in Chapter 6). It is the responsibility of the Land formation to which the LO is supporting to provide the required services (ie, the ALE will receive the required services from the Land Component Command).

75. G6 LOs. The employment of G6 LO to the higher formation can be used to good effect in order to provide situational awareness, coordination, deconfliction, advice and assistance. The LO will be able to impart the subordinate commanders main effort and priorities, whilst having the ability to provide updates to his formation regarding the recognised CIS picture, particularly in relation to the redeployment of assets, interoperability challenges and major faults. The use of G6 LOs is good practice that should be adopted as a matter of routine when employed on NATO land deployments, thus, improving situational awareness within the G6 arena.

76. In an standards based interoperability environment, the Liaison Officer may receive services from the hosting C2 entity. When interoperability is provided using asset sharing, the Liaison Officer will receive CIS services from the sending C2 entity.

CHAPTER SIX:

RESULTING SERVICE REQUIREMENTS PER TYPE OF C2 ENTITY

77. This chapter introduces the C2 services requirements for the Land C2 functional entities presented in Chapter 4:

- a. VJTF (L) BDE C2,
- b. VJTF (L) & MJO+ Intelligence,
- c. VJTF (L) & MJO+ Fire Support,
- d. VJTF (L) & MJO+ Air Support,
- e. VJTF (L) & MJO+ Logistics Support,
- f. VJTF (L) & MJO+ Medical,
- g. Land C2 Entities to Non NATO Entities.

78. The C2 services that have been used in this chapter are those as depicted in the C3 Taxonomy. The required services have been derived as a result of the IER analysis process. IER examples are detailed in Annex C. This chapter will focus on each functional area depicted above (VJTF (L) BDE, etc), with the initial focus being pictorially represented, focusing on those elements that reside at the BDE level of C2 (e.g. Logistics Support Group) and the required services from LCC down to COY level of C2 when deployed as a VJTF(L) in an SJO or MJO(+) scenario.

79. As stated in Chapter 5, bandwidth will be constrained the further towards the FLOT the C2 entity is, but the requirement still exists for that particular entity to have access to the required services. The way in which the required services are delivered and presented (ie. The General User Interface (GUI)) to user will differ depending on where you are located in the land C2 chain, however, the same core functionality of the service must be available from the highest to the lowest land C2 formation, but tailored to the requirement, and bandwidth availability, of the entity.

80. **VJTF (L) BDE C2.**

- a. Figure 6-1 summarises the H2H and C2 services required for a VJTF(L) BDE using a representational format as introduced by the C3 Taxonomy.

b. The set of services stated have been determined through IER analysis and in liaison with those BDE entities held at readiness. The stated services are the mandated minimum required and the commander may decide that he requires additional services.

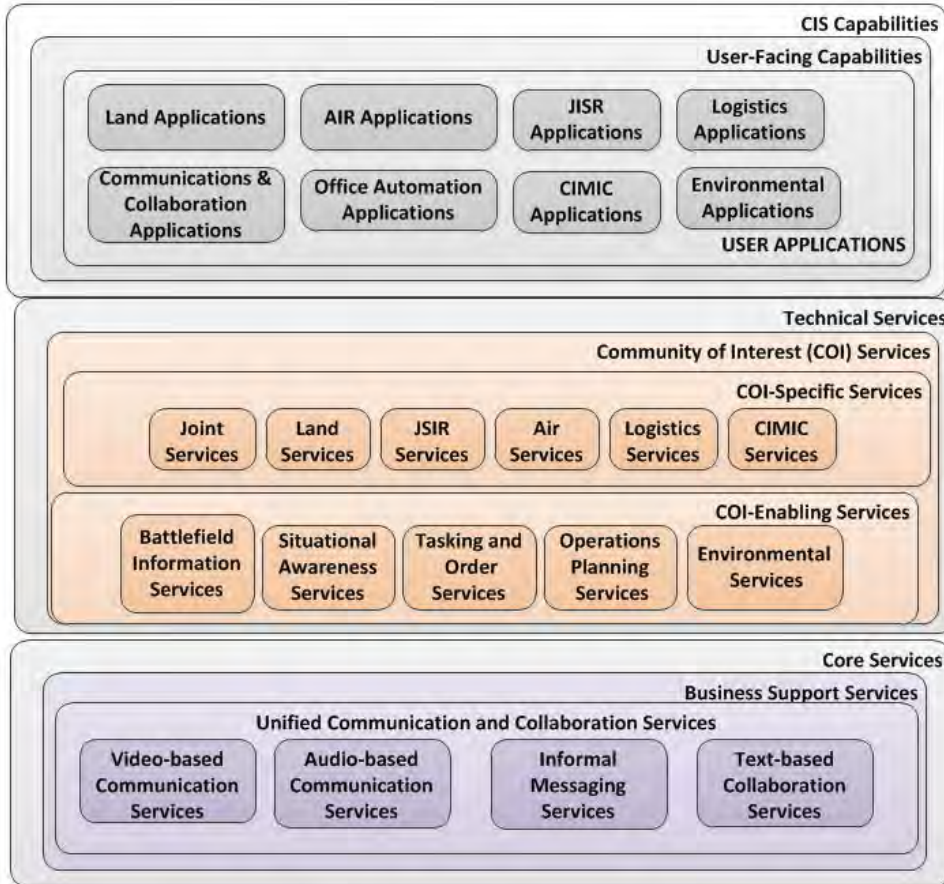

Figure 6-1: C2 and H2H Services High Readiness BDE.

c. Table 6-1 summarises the mandated H2H, Core and C2 Services required from/to the C2 nodes deployed from Corps down to COY within a high readiness environment.

NATO UNCLASSIFIED
DRAFT

SERVICE PROVISION HIGH READINESS BRIGADE: C2	CORPS	BRIGADE	BATTALION	Company
SERVICE TYPE				
HUMAN TO HUMAN SERVICES				
Audio Based Communication Services	*	*	*	*
Informal Messaging Services	*	*	*	
Text-Based Collaboration Services	*	*	*	*
Video-Based Communication Services	*	*		
CORE SERVICES (IN ADDITION TO HUMAN TO HUMAN SERVICES)				
Military Messaging Service	*	*		
COMMUNITY OF INTEREST SERVICES (COI)				
Joint Services	*	*	*	
Land Services	*	*	*	*
Air Services	*	*	*	
CIMIC Services	*	*	*	
Logistics Services	*	*	*	*
Environmental Services	*	*	*	*
Situation Awareness Services	*	*	*	*
Operations Planning Services	*	*	*	*
Tasking and Order Services	*	*	*	*
Battlefield Information Services		*	*	*
JISR Services	*	*	*	*

Table 6-1: Mandated Services Land C2 Environment

d. Table 6-2 details representative, not mandated, transmission services. The transmission services have been determined by analysing the general distance over which the entity will have to communicate, the required mobility and the types of challenging terrain that the entity may have to operate over. Whatever transmission services are employed, they are to have sufficient capacity to deliver/consume the required services in order to deliver the IER and the capability to operate on the move if required.

	CORPS	BRIGADE	BATTALION	Company
TRANSMISSION SERVICES				
Wired Transmission Services				
Wired Local Area Transmission Services	*	*	*	
Wired Metropolitan Area Transmission Services	*			
Wired Wide Area Transmission Services	*			
Wireless Line of Sight (LOS) Static Transmission Services				
Wireless LOS Static Wideband Transmission Services	*			
Wireless Line of Sight (LOS) Mobile Transmission Services				
Wireless LOS Mobile Narrowband Transmission Services		*	*	*
Wireless Beyond Line of Sight (BLOS) Static Transmission Services				
Wireless BLOS Static Narrowband Transmission Services	*			
Wireless BLOS Static Wideband Transmission Services	*	*		
Wireless Beyond Line of Sight (BLOS) Mobile Transmission Services				
Wireless BLOS Mobile Narrowband Transmission Services		*	*	*

Table 6-2: Representative Transmission Services Land C2 Environment

e. An example IER for the Land C2 environment can be found at Annex C.

81. **Intelligence.**

a. Figure 6-2 summarises the H2H and C2 services required to enable the effective collection, exploitation, dissemination and receipt of intelligence product using a representational format as introduced by the C3 Taxonomy, focusing on the All Sources Analysis Cell (ASAC) located at BDE HQ.

b. The set of services stated have been determined through IER analysis and in liaison with those BDE entities held at readiness. The stated services are the mandated minimum required and the commander may decide that he requires additional services.

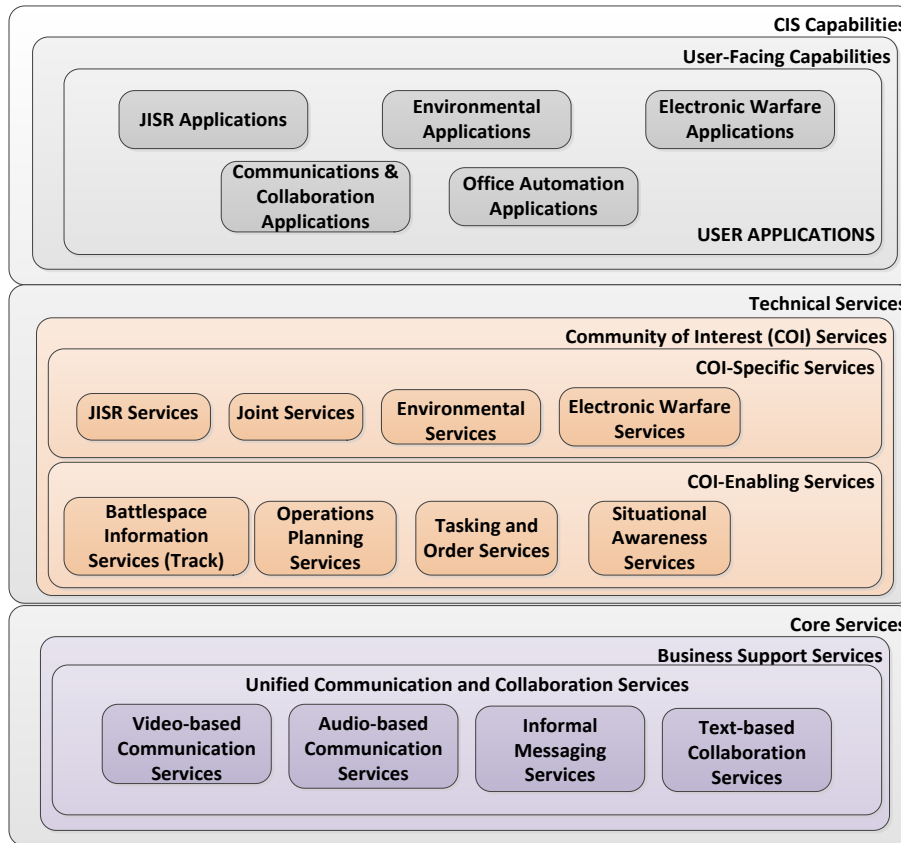

Figure 6-2: C2 and H2H BDE All Sources Analysis Cell

c. Table 6-3 summarises the mandated H2H, Core and C2 Services required from/to the C2 intelligence nodes for example the Land Intelligence Fusion Centre (LIFC) deployed at the Land Component Command (LCC) in a MJO+ scenario down to the COY Intelligence and Security Team (COIST) deployed at the COY level of C2.

NATO UNCLASSIFIED
DRAFT

INTELLIGENCE	LANDCOM	CORPS	DIV/BDE	Battle Group	Company
SERVICE TYPE	Land Intelligence Fusion Centre (LIFC)	Corps Intelligence Fusion Centre (CIFC)	All Sources Analysis Cell (ASAC)	Battle Group Intelligence Support Section (BGISS)	Company Intelligence Support Team (COIST)
HUMAN TO HUMAN SERVICES					
Audio-Based Communication Services	*	*	*	*	*
Informal Messaging Services	*	*	*		
Text-Based Collaboration Services	*	*	*	*	*
Video-Based Communication Services	*	*	*		
CORE SERVICES (IN ADDITION TO HUMAN TO HUMAN SERVICES)					
Military Messaging Service	*	*	*		
Fax Services			*		
COMMUNITY OF INTEREST SERVICES (COI SPECIFIC)					
Joint Services	*	*	*		
JISR Services	*	*	*	*	*
Environmental Services	*	*	*		
Electronic Warfare Services	*	*	*		
COMMUNITY OF INTEREST SERVICES (COI ENABLING)					
Operational Planning Services	*	*	*	*	*
Tasking and Order Services	*	*	*	*	*
Situational Awareness Service	*	*	*	*	*
Tasking & Order Services (Operations Assessment Services)	*	*	*	*	*

Table 6-3: Mandated Services Land Intelligence C2 Assets

d. Table 6-4 details representative, not mandated, transmission services. The transmission services have been determined by analysing the general distance over which the entity will have to communicate, the required mobility and the types of challenging terrain that the entity may have to operate over. Whatever transmission services are employed, they are to have sufficient capacity to deliver/consume the required services in order to deliver the IER and the capability to operate on the move if required. An example IER for the Land Intelligence environment can be found at Annex C.

	LANDCOM	CORPS	DIV/BDE	Battle Group	Company
	Land Intelligence Fusion Centre (LIFC)	Corps Intelligence Fusion Centre (CIFC)	All Sources Analysis Cell (ASAC)	Battle Group Intelligence Support Section (BGISS)	Company Intelligence Support Team (COIST)
TRANSMISSION SERVICES					
Wired Transmission Services					
Wired Local Area Transmission Services	*	*	*		
Wired Metropolitan Area Transmission Services	*	*			
Wireless Line of Sight (LOS) Static Transmission Services					
Wireless LOS Static Wideband Transmission Services	*	*	*		
Wireless Line of Sight (LOS) Mobile Transmission Services					
Wireless LOS Mobile Narrowband Transmission Services			*	*	*
Wireless Beyond Line of Sight (BLOS) Static Transmission					
Wireless BLOS Static Narrowband Transmission Services	*	*			
Wireless BLOS Static Wideband Transmission Services	*	*	*		
Wireless Beyond Line of Sight (BLOS) Mobile Transmission					
Wireless BLOS Mobile Narrowband Transmission Services			*	*	*

Table 6-4: Representative Transmission Services Land Intelligence C2 Assets

82. **Fire Support.**

a. Figure 6-3 summarises the H2H and C2 services required to enable effective fire support to be provided within the Land domain using a

representational format as introduced by the C3 Taxonomy, focusing on the BDE Joint Fires Cell.

b. The set of services stated have been determined through IER analysis and in liaison with those BDE entities held at readiness. The stated services are the mandated minimum required and the commander may decide that he requires additional services.

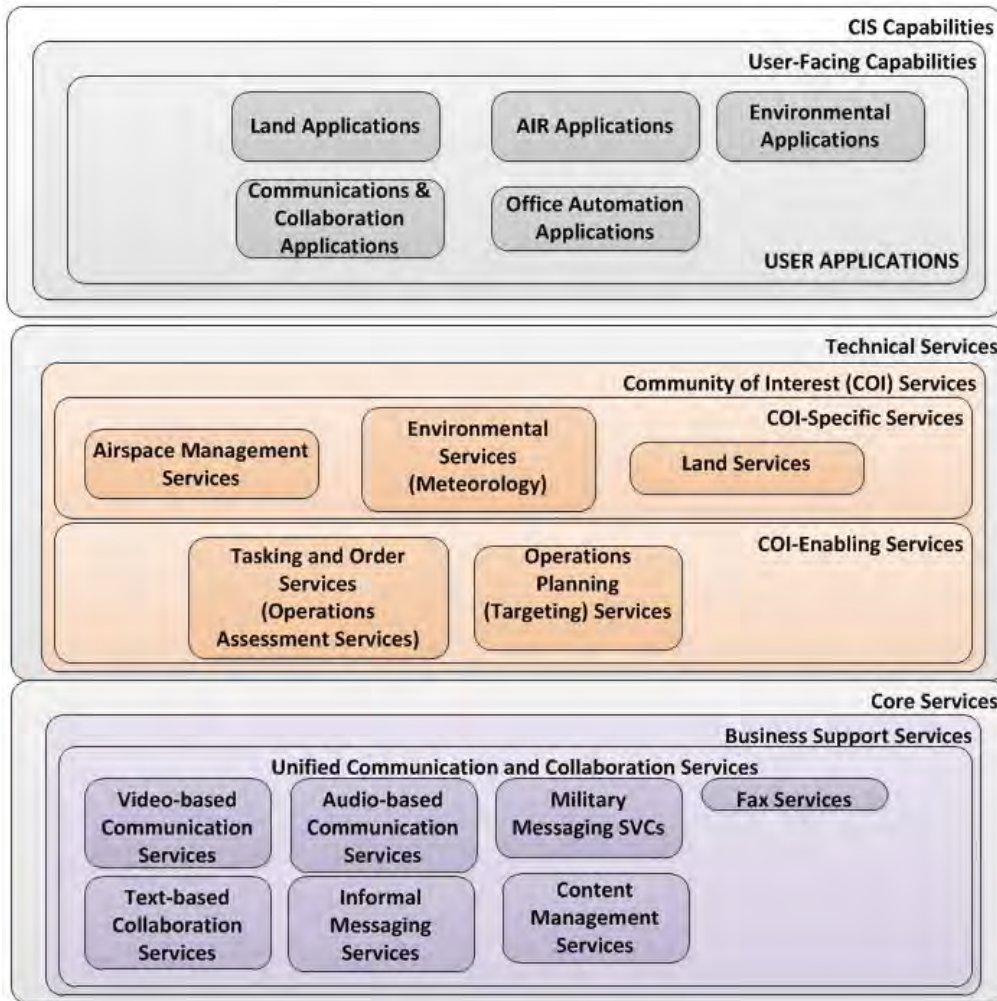

Figure 6-3: C2 and H2H Services BDE Joint Fires Cell

c. Table 6-5 summarises the H2H, Core and C2 Services mandated from/to the C2 fire support nodes for example the Fire Support Coordination Centre (FSCC) and Target Support Cell (TSC) deployed at Corps down to the COY level Fire Support Team (FST).

NATO UNCLASSIFIED
DRAFT

SERVICE PROVISION FIRE SUPPORT	LANDCOM	CORPS	DIVISON	BRIGADE	Battle Group	Company
SERVICE TYPE	LANDCOM	Corps Fire Sp Coord Centre/ Target Sp Cell	Fire Sp Coord Centre	Joint Fires Cell	Joint Fires Cell	Fire Sp Team
HUMAN TO HUMAN SERVICES						
Audio-Based Communication Services	*	*	*	*	*	*
Informal Messaging Services	*	*	*	*	*	
Text-Based Collaboration Services	*	*	*	*	*	*
Video-Based Communication Services	*	*	*	*		
CORE SERVICES (IN ADDITION TO HUMAN TO HUMAN SERVICES)						
Military Messaging Service	*	*	*	*		
COMMUNITY OF INTEREST SERVICES (COI SPECIFIC)						
Land Services	*	*	*	*	*	
Airspace Management Services	*	*	*	*	*	*
Environmental Services	*	*	*	*	*	*
COMMUNITY OF INTEREST SERVICES (COI ENABLING)						
Tasking & Order Services (Operations Assessment Services)	*	*	*	*	*	*
Operational Planning (Targeting) Services	*	*	*	*	*	*

Table 6-5: Mandated Services Land Fire Support C2 Assets

d. Table 6-6 details representative, not mandated transmission services in order to execute fire support within the land environment. The transmission services have been determined by analysing the general distance over which the entity will have to communicate, the required mobility and the types of challenging terrain that the entity may have to operate over. Whatever transmission services are employed, they are to have sufficient capacity to deliver/consume the required services in order to deliver the IER and the capability to operate on the move if required. An example IER for the Land Fire Support environment can be found at Annex C.

	LANDCOM	CORPS	DIVISON	BRIGADE	Battle Group	Company
	LANDCOM	Corps Fire Sp Coord Centre/ Target Sp Cell	Fire Sp Coord Centre	Joint Fires Cell	Joint Fires Cell	Fire Sp Team
TRANSMISSION SERVICES						
Wired Transmission Services						
Wired Local Area Transmission Services	*	*	*	*	*	
Wired Metropolitan Area Transmission Services	*	*				
Wired Wide Area Transmission Services	*	*				
Wireless Line of Sight (LOS) Static Transmission Services						
Wireless LOS Static Wideband Transmission Services	*	*	*			
Wireless Line of Sight (LOS) Mobile Transmission Services						
Wireless LOS Mobile Narrowband Transmission Services			*	*	*	*
Wireless Beyond Line of Sight (BLOS) Static						
Wireless BLOS Static Narrowband Transmission Service	*	*				
Wireless BLOS Static Wideband Transmission Services	*	*	*	*		
Wireless Beyond Line of Sight (BLOS) Mobile						
Wireless BLOS Mobile Narrowband Transmission Services			*	*	*	*

Table 6-6: Representative Transmission Services Land Fire Support C2 Assets

83. **Logistics.**

a. Figure 6-4 summarises the H2H and C2 services required to enable effective logistics support to be provided within the land environment using a representational format as introduced by the C3 Taxonomy, focusing on the BDE Logistics Support Group.

b. The set of services stated have been determined through IER analysis and in liaison with those BDE entities held at readiness. The stated services are the mandated minimum required and the commander may decide that he requires additional services.

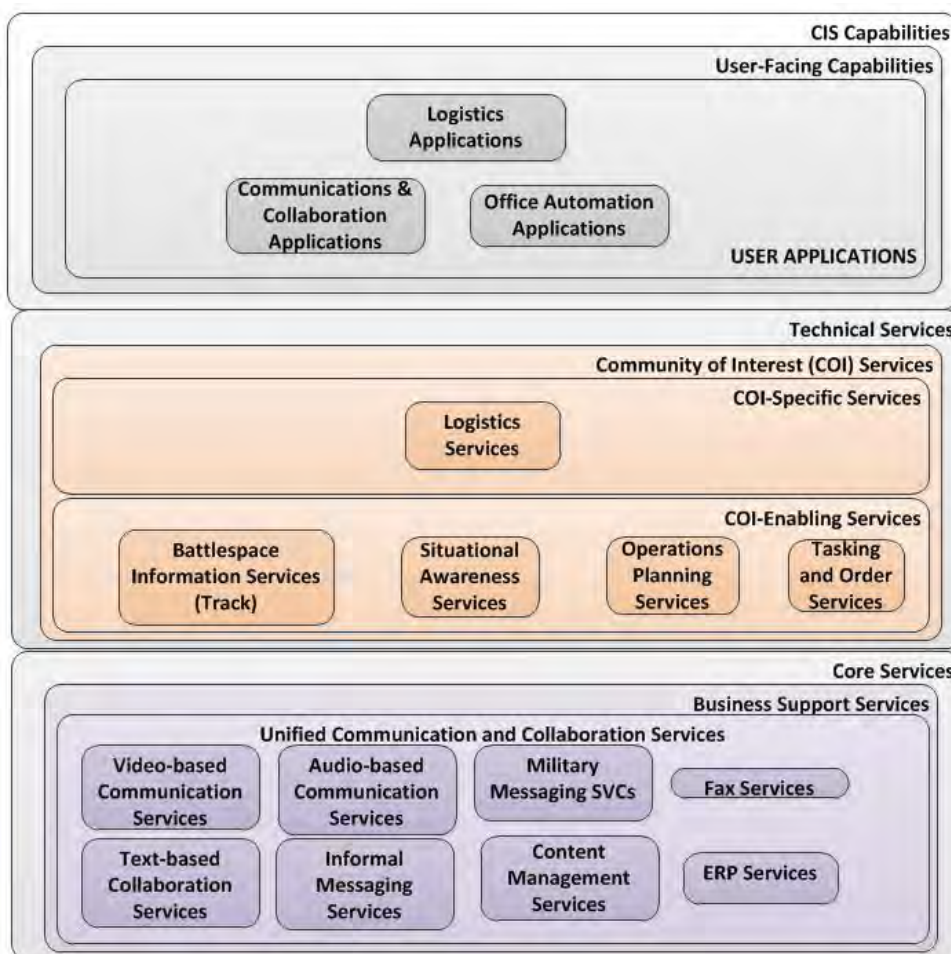

Figure 6-4: C2 and H2H Services BDE Logistics Support Group

c. Table 6-7 summarises the H2H, Core and C2 Services mandated from/to the C2 logistic nodes for example the JLSG deployed at Corps down to A1 Echelon deployed at COY level.

NATO UNCLASSIFIED
DRAFT

SERVICE PROVISION LOGISTICS	JOINT	LANDCOM	CORPS	DIVISION	BRIGADE	Battle Group	Company
SERVICE TYPE	JOINT LOGISTICS SUPPORT GROUP	LAND	CORPS REAR SUPPORT GROUP	DIVISIONAL SUPPORT GROUP	BRIGADE SUPPORT GROUP	A2 ECHELON	A1 ECHELON
HUMAN TO HUMAN SERVICES							
Audio-Based Communication Services	*	*	*	*	*	*	*
Video-Based Communication Services	*	*	*	*	*	*	
Informal Messaging Services	*	*	*	*	*	*	
Text-Based Collaboration Services	*	*	*	*	*	*	*
CORE SERVICES (IN ADDITION TO HUMAN TO HUMAN SERVICES)							
Military Messaging Service	*	*	*	*	*		
Fax Services	*	*	*	*			
COMMUNITY OF INTEREST SERVICES							
Joint Services	*	*					
Battlespace Information Services	*	*	*	*	*	*	*
Situational Awareness Service	*	*	*	*	*	*	*
Logistics Services	*	*	*	*	*	*	*
ERP Services	*	*	*	*	*		
Operational Planning Services	*	*	*	*	*	*	*
Tasking & Order Services	*	*	*	*	*	*	*

Table 6-7: Mandated Services Land Logistics C2 Assets

d. Table 6-8 details representative, not mandated, transmission services in order to conduct logistics sustainment within the land environment. The transmission services have been determined by analysing the general distance over which the entity will have to communicate, the required mobility and the types of challenging terrain that the entity may have to operate over. Whatever transmission services are employed, they are to have sufficient capacity to deliver/consume the required services in order to deliver the IER and the capability to operate on the move if required. An example IER for the Land Logistics environment can be found at Annex C.

	JOINT	LANDCOM	CORPS	DIVISION	BRIGADE	Battle Group	Company
	JOINT LOGISTICS SUPPORT GROUP	LAND	CORPS REAR SUPPORT GROUP	DIVISIONAL SUPPORT GROUP	BRIGADE SUPPORT GROUP	A2 ECHELON	A1 ECHELON
TRANSMISSION SERVICES							
Wired Transmission Services							
Wired Local Area Transmission Services	*	*	*	*	*	*	
Wired Wide Area Transmission Services	*	*	*				
Wireless Line of Sight (LOS) Static Transmission Services							
Wireless LOS Static Wideband Transmission Services	*	*	*	*			
Wireless Line of Sight (LOS) Mobile Transmission Services							
Wireless LOS Mobile Narrowband Transmission Services				*	*	*	*
Wireless Beyond Line of Sight (BLOS) Static							
Wireless BLOS Static Narrowband Transmission Services	*	*	*				
Wireless BLOS Static Wideband Transmission Services	*	*	*				
Wireless Beyond Line of Sight (BLOS) Mobile							
Wireless BLOS Mobile Narrowband Transmission Services				*	*	*	*

Table 6-8: Representative Transmission Services Logistics Support C2 Assets

84. **Air Support.**

a. Figure 6-5 summarises the H2H and C2 services required to enable air support to be executed in support of land based operations using a representational format as introduced by the C3 Taxonomy, focusing on the Air Liaison Officer (ALO)/Air Support Operations Cell (ASOC) located at the BDE level of C2.

b. The set of services stated have been determined through IER analysis and in liaison with those BDE entities held at readiness. The stated services

are the mandated minimum required and the commander may decide that he requires additional services.

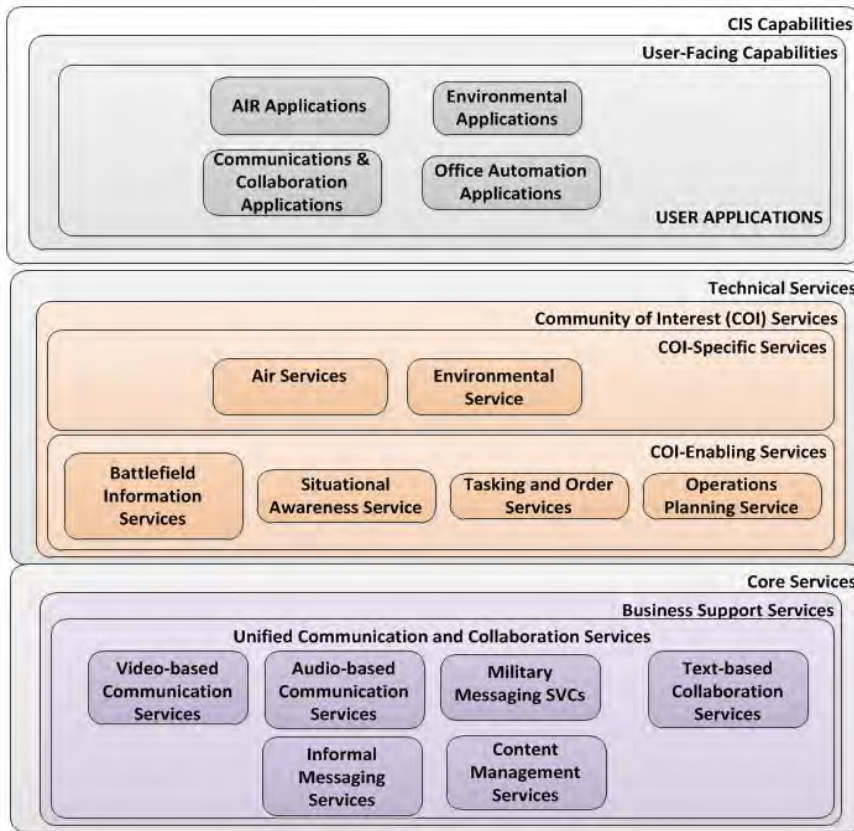

Figure 6-5: C2 and H2H Services BDE Air Liaison Officer/Air Support Operations Centre

c. Table 6-9 summarises the H2H, Core and C2 Services mandated from/to the C2 air support nodes for example the Air Liaison Element located at the Land Component Command down to Forward Air Controller (FAC) located at COY.

NATO UNCLASSIFIED
DRAFT

SERVICE PROVISION CLOSE AIR SUPPORT	LANDCOM	CORPS	DIVISON	BRIGADE	BATTALION	Company
SERVICE TYPE	Air Liaison Element	Air Operations Coordination	Division Air Liaison Officer	Brigade Air liaison Officer	Tactical Air Control Party	Forward Air Controller
HUMAN TO HUMAN SERVICES						
Audio Based Communication Services	*	*	*	*	*	*
Informal Messaging Services	*	*	*	*		
Text-Based Collaboration Services	*	*	*	*	*	*
Video-Based Communication Services	*	*	*	*		
CORE SERVICES (IN ADDITION TO HUMAN TO HUMAN SERVICES)						
Informal Messaging Services	*	*	*	*		
Military Messaging Service	*	*	*	*		
COMMUNITY OF INTEREST SERVICES (COI)						
Air Services	*	*	*	*	*	*
Situation Awareness Services	*	*	*	*		
Environmental Services	*	*	*	*	*	*
Operations Planning Services	*	*	*	*	*	
Tasking and Order Services	*	*	*	*	*	*
Battlefield Information Services				*	*	*

Table 6-9: Mandated Services Air Support for Land Operations

d. Table 6-10 details representative, not mandated transmission services in order to enable air support to be provided within the land environment. The transmission services have been determined by analysing the general distance over which the entity will have to communicate, the required mobility and the types of challenging terrain that the entity may have to operate over. Whatever transmission services are employed, they are to have sufficient capacity to deliver/consume the required services in order to deliver the IER and the capability to operate on the move if required. An example IER for the Air Support in the land environment can be found at Annex C.

	LANDCOM	CORPS	DIVISON	BRIGADE	BATTALION	Company
	Air Liaison Element	Air Operations Coordination Centre	Division Air Liaison Officer	Brigade Air liaison Officer	Tactical Air Control Party	Forward Air Controller
TRANSMISSION SERVICES						
Wired Transmission Services						
Wired Local Area Transmission Services	*	*	*	*		
Wired Metropolitan Area Transmission Services	*	*				
Wired Wide Area Transmission Services	*	*				
Wireless Line of Sight (LOS) Static Transmission Services						
Wireless LOS Static Wideband Transmission Services	*	*	*			
Wireless Line of Sight (LOS) Mobile Transmission Services						
Wireless LOS Mobile Narrowband Transmission Services			*	*	*	*
Wireless Beyond Line of Sight (BLOS) Static Transmission						
Wireless BLOS Static Narrowband Transmission Services	*	*				
Wireless BLOS Static Wideband Transmission Services	*	*	*	*		
Wireless Beyond Line of Sight (BLOS) Mobile Transmission						
Wireless BLOS Mobile Narrowband Transmission Services			*	*	*	*

Table 6-10: Representative Transmission Services Air Support C2 Assets

85. Medical.

a. Figure 6-6 summarises the H2H and C2 services required to enable medical evacuation to be conducted in support of Land based operations using a representational format as introduced by the C3 Taxonomy, focusing

on the Patient Evacuation Coordination Cell (PECC) located at the BDE level of C2.

b. The set of services stated have been determined through IER analysis and in liaison with those BDE entities held at readiness. The stated services are the mandated minimum required and the commander may decide that he requires additional services.

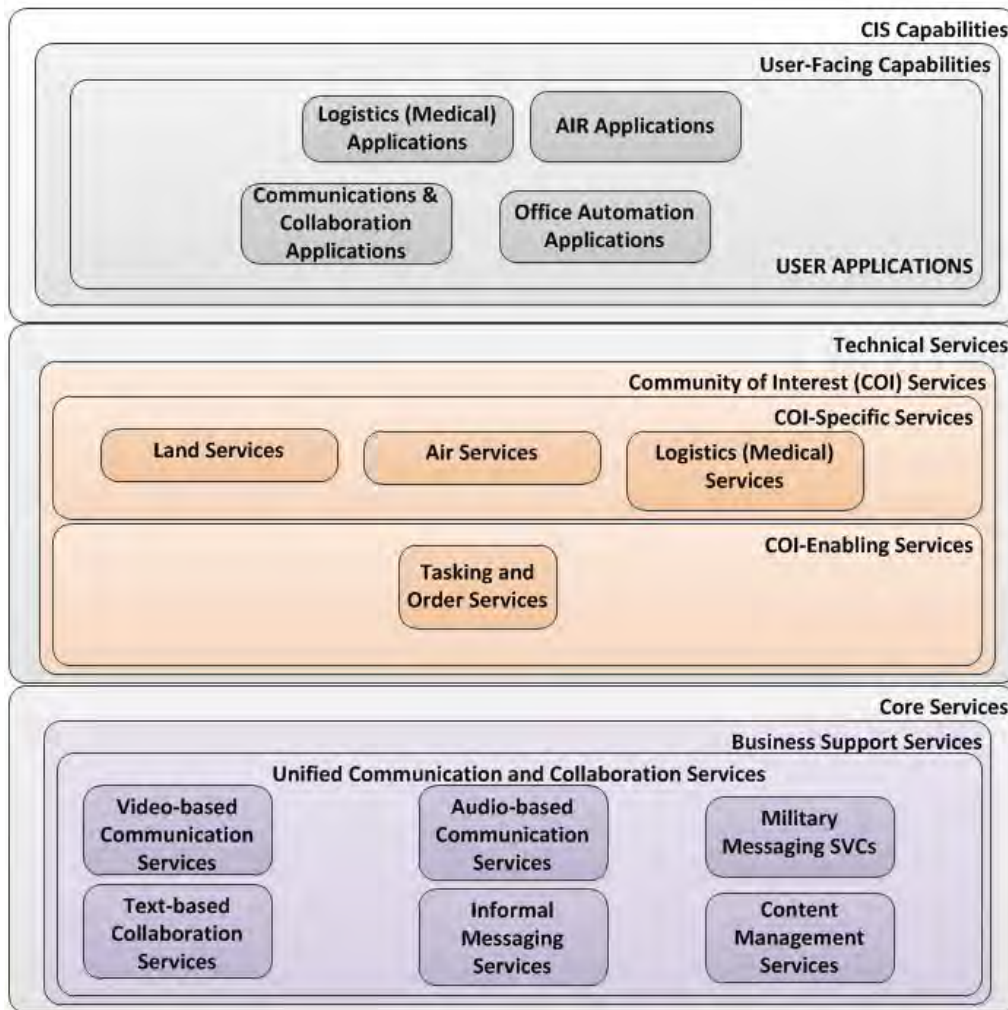

Figure 6-6: C2 and H2H Services BDE Patient Evacuation Coordination Cell

c. Table 6-11 summarises the H2H, Core and C2 Services mandated from/to the C2 medical entities for example the senior medical advisor based at the LCC to unit aid post located at COY level.

NATO UNCLASSIFIED
DRAFT

SERVICE PROVISION MEDICAL SUPPORT	LANDCOM	CORPS	CORPS	DIVISON	BRIGADE	BRIGADE	BATTLEGROUP	Company
SERVICE TYPE	LANDCOM Senior Medical Advisor	Patient Evac Coord Centre	Role 3 Medical Treatment Facility	Patient Evac Coord Centre	Patient Evac Coord Centre	Role 2 Medical Treatment Facility	BATTLEGROUP HQ	Team Medic (At Point of Wounding)
HUMAN TO HUMAN SERVICES								
Audio Based Communication Services	*	*	*	*	*	*	*	*
Informal Messaging Services	*	*	*	*	*	*	*	*
Text-Based Collaboration Services	*	*	*	*	*	*	*	*
Video-Based Communication Services	*	*	*	*	*	*		
CORE SERVICES (IN ADDITION TO HUMAN TO HUMAN SERVICES)								
Military Messaging Service	*	*	*	*	*	*		
COMMUNITY OF INTEREST SERVICES (COI)								
Air Services		*		*	*			
Logistics (Medical) Services	*	*	*	*	*	*	*	*
Tasking & Order Services	*	*	*	*	*	*	*	*
Land Services		*	*	*	*	*		*

Table: 6-11: Mandated Medical Services for Land Operations

d. Table 6-12 details representative, not mandated, transmission services in order to enable medical support to be provided within the land environment. The transmission services have been determined by analysing the general distance over which the entity will have to communicate, the required mobility and the types of challenging terrain that the entity may have to operate over. Whatever transmission services are employed, they are to have sufficient capacity to deliver/consume the required services in order to deliver the IER and the capability to operate on the move if required. An example IER for the Land Medical environment can be found at Annex C.

	LANDCOM	CORPS	CORPS	DIVISON	BRIGADE	BRIGADE	BATTLEGROUP	Company
	LANDCOM Senior Medical Advisor	Patient Evac Coord Centre	Role 3 Medical Treatment Facility	Patient Evac Coord Centre	Patient Evac Coord Centre	Role 2 Medical Treatment Facility	BATTLEGROUP HQ	Team Medic (At Point of Wounding)
TRANSMISSION SERVICES								
Wired Transmission Services								
Wired Local Area Transmission Services	*	*	*	*	*	*	*	
Wired Metropolitan Area Transmission Services	*	*	*					
Wired Wide Area Transmission Services	*	*	*					
Wireless Line of Sight (LOS) Static Transmission Services								
Wireless LOS Static Narrowband Transmission Services			*			*		
Wireless LOS Static Wideband Transmission Services	*	*	*	*		*		
Wireless Line of Sight (LOS) Mobile Transmission Services								
Wireless LOS Mobile Narrowband Transmission Services				*	*		*	*
Wireless Beyond Line of Sight (BLOS) Static Transmission								
Wireless BLOS Static Narrowband Transmission Services	*	*				*		
Wireless BLOS Static Wideband Transmission Services	*	*	*	*	*	*		
Wireless Beyond Line of Sight (BLOS) Mobile Transmission								
Wireless BLOS Mobile Narrowband Transmission Services				*	*		*	*

Table 6-12: Representative Transmission Services Medical Support C2 Assets

CHAPTER SEVEN: ENABLING SERVICES

SPECTRUM MANAGEMENT

86. Without a licensed assignment the use of a frequency (band) is prohibited. Units/elements are to ensure the following actions are taken prior to transmitting on any frequency. The procedures summarised here are fully described in ACP 190 NS-1(C) (Reference S).

87. During the planning phase of an exercise or operation all units and/or elements intending to operate wireless emitting devices have to state their Radio Frequency Spectrum (RFS) requirements following the chain of command up to the Lead Spectrum Management Office (SMO) residing at the Joint Task Force (JTF) or LCC level of C2, following the format published by the Lead SMO. The statement of requirements is only a summary and does not constitute an assignment request. The Lead SMO will collate and submit the frequency requirements for the deployment to the National Allied Radio Frequency Agency (NARFA). Depending on the nature of the JOA (i.e., the deployment is dispersed over more than one country), the requests may have to be submitted to more than one NARFA. The host NARFA(s) will then provide allotments to the Lead SMO allowing the Lead SMO to assign frequencies to the units.

88. The lead SMO is the only authority entitled to issue licenses to transmit within the JOA. Units existing assignments carried from home bases must not be used within the JOA unless they have been coordinated with the Lead SMO. Frequency assignment requests must be filled in properly by the units in the format published by the Lead SMO (normally Spectrum Management Allied Format (SMADEF-XML) or Standard Frequency Action Format (SFAF)), completed and submitted through the chain of command up to the Lead SMO at least 30, but recommended 90 days in advance prior to their deployment and required assignment date.

89. The Lead SMO will issue frequency assignments and associated licenses in response to frequency assignment requests, from allotments received from the host NARFA(s) or through further coordination with the host NARFA(s) and neighbouring NARFA(s) as required.

NATO UNCLASSIFIED
DRAFT

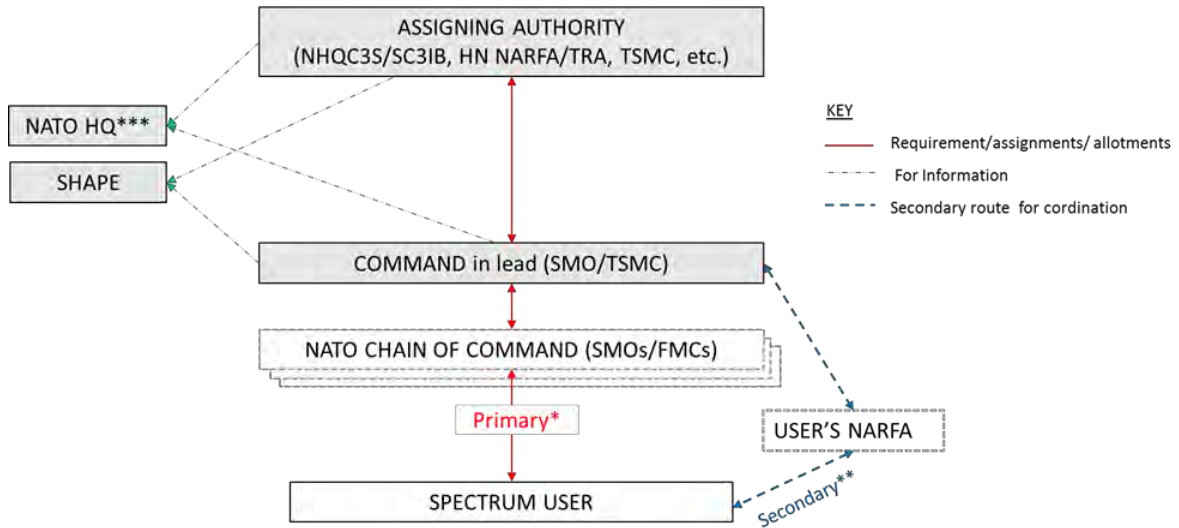

* Primary route for frequency coordination.

** Secondary route for frequency coordination if user doesn't know his Chain of Command. NARFAs must always go the the Command in lead/TSMC

*** NHQC3S/SC3IB can lead/support the coordination process as required by the Command in lead.

Figure 7-1: Frequency Request and Assignment Flow

ABBREVIATIONS

A	
ACC	Air Component Command
ACM	Airspace Control Measures
ACO	Air Coordination Order
AH	Attack Helicopter
AH BN HQ	Attack Helicopter Battalion Headquarters
ALE	Air Liaison Element
AMEA	Air Medical Evacuation Asset
AOCC	Air Operations Coordination Centre
APOD	Airport of Disembarkation
AS	Air Support
ASAC	All Sources Analysis Cell
ASOC	Air Support Operations Centre
ASSESSREP	Assessment Report
ATO	Air Tasking Order
AOR	Area of Responsibility
A1C	A1 Echelon (Logistics Function at Company)
A2C	A2 Echelon (Logistics Function at Battle Group)
B	
BALO	Brigade Air Liaison Officer
BASO	Brigade Air Support Officer
BDE	Brigade
BG	Battle Group
BFDC	Brigade Fire Direction Centre
BN	Battalion
BCM	Battlefield Control Measures
BDA	Battle Damage Assessment
BGISS	Battle Group Intelligence Support Section
BIA	Battlefield Information Applications
BLOS	Beyond Line of Sight
BMS	Battle Management System
BMU	Brigade Medical Evacuation Unit
BP	Back loading Point
BSG	Brigade Support Group
BPECC	Patient Evacuation Coordination Centre at Brigade Level
BR2MTF	Role 2 Medical Treatment Facility at Brigade Level

C	
CAOC	Combined Air Operations Centre
CAS	Close Air Support
CASEVAC	Casualty Evacuation Report
CASREP	Casualty Report
CIMIC	Civil and Military Cooperation
CIS	Communication and Information Systems
CCIR	Commander's Critical Intelligence Requirements
CCT	Component Critical Target List
CIFC	Corps Intelligence Fusion Cell
CISOA	CIS Operational Authority
CISPIA	CIS Planning and Implementation Authority
CISP	CIS Provider
CNAD	Conference of National Armaments Directors
CNR	Combat Network Radio
COI	Community of Interest
COIST	Company Intelligence Support Team
COP	Common Operational Picture
COY HQ	Company Headquarters
CRP	Crisis Response Planning
CRSG	Corps Rear Support Group
CTL	Collection Task List
CXP	Collection & Exploitation Plan
CPECC	Corps Patient Evacuation Coordination Center
CR3MTF	Corps Role 3 Medical Treatment Facility
C2	Command and Control
C2IS	Command and Control Information System
D	
DALO	Division Air Liaison Officer
DASO	Division Air Support Officer
DCIS	Deployable Communications & Information Systems
DED	Data Entry Device
DPoP	Deployable Point of Presence
DSG	Division Support Group
DPECC	Division Patient Evacuation Coordination Centre
E	
ECCP	Equipment Collection Coordination Point
EEP	Emergency Evacuation Point
ENSITREP	Enemy Situation Report

ES Request	Equipment Support Request
ETA Report	Estimated Time of Arrival Report
EUA	Evacuation Unit Ambulance
EWCC	Electronic Warfare Coordination Cell
EW Info	Electronic Warfare Information
ERP	Enterprise Resource Planning
F	
FAC	Forward Air Controller
FFT	Friendly Force Tracking
FLOT	Front Line of Own Troops
FLT	Frontline Troops
FMN	Federated Mission Network
FMV	Full Motion Video
FRAGO	Fragmentary Order
FRT	Forward Repair Team
FST	Fire Support Team
FSCC	Fire Support Coordination Centre
FoF	Follow on Forces
G	
GLE	Ground Liaison Element
GRF-L	Graduated Response Force-Land
GUI	General User Interface
H	
HC-BLOS	High Capacity Beyond Line of Sight (Digital Troop scatter)
HCDR	High Capacity Data Radio (UHF, range up to 15 km, up to 50 kbit/s)
HF	High Frequency
HN	Host Nation
HPTL	High Pay Off Target List
HUMINT	Human Intelligence
HVTL	High Value Target List
HQ	Headquarters
H2H	Human to Human
I	
IA	Information Assurance
IER	Information Exchange Requirement
ICE	Initial Command Element
ICP	Intelligence Collection Plan
ICT	Information Communication Technology

IEG	Information Exchange Gateway
IFFG	Initial Follow-on Forces
INM	Interface with Nations Module
INTREP	Intelligence Report
ISR	Intelligence, Surveillance & Reconnaissance
ISRR	Intelligence, Surveillance & Reconnaissance Request
ISTAR	Intelligence, Surveillance, Target Acquisition, Reconnaissance
ITM	Interface Termination Module
IOP	Interoperability Point
J	
JCO	Joint Coordination Order
JDSS	Joint Dismounted Soldier Systems
JDSSIN	Joint Dismounted Soldier Systems Information Network
JFAC	Joint Force Air Component Command
JFC	Joint Fires Cell
JFCBDE	Joint Fires Cell (at Brigade)
JFCBG	Joint Fires Cell (at Battle Group)
JFTSC	Joint Force Target Support Cell
JLSG	Joint Logistics Support Group
JOA	Joint Operational Area
JSMA	Joint Senior Medical Advisor
JTF HQ	Joint Task Force Headquarters
JOA	Joint Operations Area
JPTL	Joint Prioritized Target List
JTL	Joint Target List
L	
L	Land
LCC	Land Component Command
LIFC	Land Intelligence Fusion Cell
LO	Liaison Officer
LOGASSESSREP	Logistics Assessment Report
LOS	Line of Sight
LSMA	Land Command Senior Medical Advisor
M	
MAF	Mission Anchor Function
MATDEM	Material Demand
MC	Maintenance Company

MCSMA	Multinational CIS Security Management Authority
MCU	Multipoint Control Unit
METEOC Info	Meteorology Information
M&T Info	Movement and Transportation Information
MED ASSESSREP	Medical Assessment Report
MED INCREP	Medical Incident Report
MEDINTREP	Medical Intelligence Report
MEDSITREP	Medical Situation Report
METEOC Info	Meteorology Information
MIEXREP	Motion Imagery Exploitation Report
MIST Report	Mechanism of Injury, Illness or Injuries Signs Unknown, Treatment Given Report
MJO	Major Joint Operation
MMR	Minimum Military Requirements
MN	Mission Network
MNE	Mission Network Element
MNOC	Mission Network Operations Centre
MNX	Mission Network Extension
MOVSITREP	Movement Situation Report
MSAB	Mission Security Accreditation Board
MTF	Medical Treatment Facility
MTF	Message Text Format
N	
NARFA	National Allied Radio Frequency Agency
NBWF	Narrow Band Wave Form
NCIA	NATO Communications and Information Agency
NCIRC	NATO Computer Incident Response Capability
NCS	NATA Command Structure
NDF	NATO Defence Forces
NDPP	NATO Defence Planning Process
NFFI	NATO Friendly Force Identification
NFIU	NATO Force Integration Unit
NFS	NATA Force Structure
NIC	National Intelligence Cell
NIP	Network Interconnection Points
NISP	NATO Interoperability Standards and Profiles
NNN	Non NATO Nations
NRF	NATO Reaction Forces

NSE	National Support Element
NS	NATO Secret
NSL	No Strike List
NSVS	NATO Secure Voice Strategy
NRF	NATO Response Force
NU	NATO Unclassified
O	
OPCIS	Operational CIS
OPLAN	Operational Plan
OPSCEN	Operations Centre
ORBAT	Order of Battle
OSINT	Open Source Intelligence
OWNSITREP	Own Forces Situation Report
P	
PCAL	Prioritized Critical Asset List
PECC	Patient Evacuation Coordination Centre
PERSREP	Personnel Report
PIR	Priority Intelligence Requirements
POW	Point of Wounding
PTL	Prioritized Target List
PTT	Push To Talk
R	
RAP	Recognized Air Picture
RESUP Plan	Resupply Plan
RFI	Request For Information
RFS	Radio frequency Spectrum
RGP	Recognized Ground Picture
RLP	Recognized Logistics Picture
RLS Request	Real Life Support Request
RMP	Recognized Maritime Picture
RIP	Recognized Intelligence Picture
RMedP	Recognized Medical Picture
RSOM Plan	Receipt, Staging & Onward Movement Plan
RSOM Op Order	Receipt, Staging & Onward Movement Operation Order
RTO Rpts	Response to Originator Reports
RTL	Restricted Target List
S	
SAA	Security Accreditation Authority

SALTA Report	Size, Activity, Location, Time of Sighting, Actions (to include requires MEDEVAC)
SCA	Software Communications Architecture
SFAF	Standard Frequency Action Format
SHF	Super High Frequency
SITREP	Situation Report
SJO	Small Joint Operation
SMA	Service Management Authority
SMADEF	Spectrum Management Allied Format
SME	Subject Matter Expert
SMTP	Simple Mail Transfer Protocol
SMO	Spectrum Management Office
SOC	Security Operations Centre
SOC	Special Operation Centre
SOCC	Special Operations Component Command
SOP	Standard Operation Procedure
SPOD	Seaport of Disembarkation
SpSp	(FMN) Spiral Specifications
Supp & Matt Info	Supply and Materials Information
T	
TACP	Tactical Air Control Party
TACCIS	Tactical CIS
TCN	Troop Contribution Nation
TEA	Target Engagement Authority
TECHINT	Technical Intelligence
TM	Team Medical at Point of Wounding
TNL	Target Nomination List
TSC	Target Support Cell
TST	Time Sensitive Target
TVB	Tactical Voice Bridge
U	
UA	Unit Ambulance
UAP	Unit Aid Post
UAS	Unmanned Aerial Surveillance
UHF	Ultra High Frequency
V	
VHF	Very High Frequency
VJTF(L)	Very High Readiness Joint Task Force (Land)

NATO UNCLASSIFIED
DRAFT

ANNEX A TO
Draft MC 0640

VTC	Video Tele-Conference
W	
WNGO	Warning Order
X	
XMPP	Extensible Messaging & Presence Protocol

NATO UNCLASSIFIED
DRAFT

ANNEX B TO
Draft MC 0640

DEFINITIONS

No	Title/Subject	Abbreviation	Definition	Reference
1	Asset Based Interoperability		Where services are not yet standardised, asset based interoperability can be applied to the land tactical environment. For the OPCIS layer, this could be the sharing of the same application or appliance, and that the mobile layer it might even be required to exchange radios or network nodes to achieve interoperability.	
2	Audio-Based Collaboration		An audio-based collaboration service provides a two-way simultaneous audio transmission among two or more remote parties on the network, including call set-up and call co-ordination in a bi-directional manner.	
3	Bearer Service		A type of telecommunication service that provides the capability for the transmission of signals between user-network interfaces.	AAP-31 Edition 3 (2005)
4	Command and Control Service		Refers to the overall provisioning of Functional, Command & Control and Core Services (including the software and the licenses) supported by adequate CIS in order to support commander's execution of Command and Control, the Staff Decision Making Process and Information Management. These CIS are composed of Communications Systems and of Information Systems hosting the various Services.	MC 0593/1 (2017)

NATO UNCLASSIFIED
DRAFT

ANNEX B TO
Draft MC 0640

No	Title/Subject	Abbreviation	Definition	Reference
5	Common Operational Picture	COP	A snapshot in time of friendly, neutral and adversary forces and of the battle space environment shared by more than one command. It facilitates collaborative planning and assists all echelons to achieve situational awareness. It is comprised of data from recognized pictures such as the Recognized Ground, Maritime, Air and Space Pictures compiled and managed by skilled and accredited Subject Matter Experts (SME).	ACO Directive (AD) 80-80 of 29 May 09
6	FMN Spiral Specification Roadmap		The FMN affiliates (including NATO) produce and agree a new FMN Spiral specification every 2 years, to increase the level of federation across mission partners. The FMN spiral specification roadmap outlines a 10-year plan for this federation ambition. An approved spiral specification will define all processes, procedures and technical standards that shall be used to implement that upcoming specification.	
7	Functional Area	FA	The area of responsibility within an organization where specific operational, administrative or technical functions are performed. Examples: Personnel, intelligence, operations, plans, training and logistics which provide train and direct COP production capabilities and SME's.	AAP-31(A) (2005)

NATO UNCLASSIFIED
DRAFT

ANNEX B TO
Draft MC 0640

No	Title/Subject	Abbreviation	Definition	Reference
8	Functional Service/ Community of Interest Services	FS / COI	A service that provides a capacity to a specific staff function where the information content is closely related to the service Examples: Maritime picture, Geospatial and METOC information, personnel management, intelligence analysis.	
9	Informal Messaging		The informal Messaging service provides exchange of electronic, text-based unformatted messages between parties on the network, with a possibility to attach digital documents to messages.	
10	Information Exchange Requirement	IER	IERs define the need for information exchange between two or more parties that support a given process. ... IERs are pivotal inputs to the CIS planning process. They ensure all relevant C2 services required in support of the mission are identified, and adequate planning and provision of C2 services can be achieved.	AJP-6 Edition A Version 1 (2017)
11	Interoperability		The ability to act together coherently, effectively and efficiently to achieve Allied tactical, operational and strategic objectives.	AAP 6 (2016)

NATO UNCLASSIFIED
DRAFT

ANNEX B TO
Draft MC 0640

No	Title/Subject	Abbreviation	Definition	Reference
12	Interoperability Point	IOP	An interoperability point defines the technical requirements for interoperability at a physical interconnection point between two networks to support one or more C2 services across the interconnection point. The definition covers everything from low level physical aspects like connector type and transmission media via network protocols to session and application protocols and information standards. Where necessary, an IOP also comprising IA standards to be applied. An interconnection point must be understood as the physical instance of an IOP, and usually take the form of a socket/plug combination.	MC 0593/1 (2017)
13	Localized Operational Picture		A localised operational picture depicts operational information relevant to the area of operations of a tactical entity. E.g., a Infantry platoon is interested in the situation within a diameter of e.g. 1 km around its current location, while the BG is interested in battlespace objects within a reach of e.g. 15 kms. The localises operational picture therefore only depicts the local battlespace elements of interest to the unit, filtered and cleared to a level that allows sharing of object information on the restricted level.	

NATO UNCLASSIFIED
DRAFT

ANNEX B TO
 Draft MC 0640

No	Title/Subject	Abbreviation	Definition	Reference
14	Mission Anchor Function	MAF	The Mission Anchor Function contains all functionality needed to establish and anchor deployable CIS services. The Mission Anchor Function is hosted in non-deployable DCIS Infrastructure. It hosts all services required to support the deployable CIS components and to interconnect them to the static environment. Main components of the MAF are the Deployed Operations Gateways (DOG) and the Mission Information Rooms. Each Mission/Operation is supported by a dedicated MAF. The MAF supports NS, MS and MU information security domains.	MC 0593/1 (2017)
15	Mission Network		The Mission Network is the federation of all Mission network contributions of the Nations participating in the Mission. It is the main CIS asset for the mission commander.	
16	Mission Network Operations Centre	MNOC	The central Mission network operations centre. In a NATO lead mission using DCIS assets, such MNOC is located in the Mission Anchor Function, overlooking the Mission network, and liaising/coordination with the NATO static SMC capabilities.	
17	Mission Security Operations Centre	MSOC	Managing the CIS Security and technical Cyber Defence activities, in a NATO led mission collocated with the MNOC in the MAF, and closely liaising and consulting with the static NATO Security operations centre.	

NATO UNCLASSIFIED
DRAFT

ANNEX B TO
Draft MC 0640

No	Title/Subject	Abbreviation	Definition	Reference
18	Mobility		The ability of an entity to be moved by its associated means while retaining its availability during the move.	AAP-31 Edition 3 (2005)
19	Operational CIS	OPCIS	Represents the non-mobile layer of the tactical network and its CIS elements, e.g. Corps to BGE level. Interconnectivity is typically provided by High Capacity LOS and BLOS systems, and native IP communication between C2 elements at OPCIS layer is feasible. It is assumed that the OPCIS is fully compliant with FMN principles.	
20	Recognized Air Picture	RAP	<p>A RAP is an electronically produced display compiled from radar and other sources covering a three-dimensional volume of an air space in which all detected air contacts has been evaluated and assigned an identification designation and a track number.</p> <p>The RAP can contain track data from the Ground and Maritime/Amphibious Battle Dimensions such as 'Aviation' helicopters and UAV's.</p>	Bi-SC NATO COP CONOPS (2001)
21	Recognized Ground Picture	RGP	An RGP is an electronically produced collection and display of data compiled from various sources, including Friendly Force Tracking Systems, ISR and Intelligence, covering a defined geographical AOI of the Ground Battle Dimension.	Bi-SC NATO COP CONOPS (2001)

NATO UNCLASSIFIED
DRAFT

ANNEX B TO
Draft MC 0640

No	Title/Subject	Abbreviation	Definition	Reference
22	Recognized Maritime Picture	RMP	A RMP is an integrated geographical presentation of the maritime picture, which is composed of all-source contact and planning data known at a given time, including surface, sub-surface and amphibious and maritime air units, forces and operations in a designated area.	Bi-SC NATO COP CONOPS (2001)
23	Recognized Picture	RP	The RP is a display of the force disposition (e.g. friendly, hostile, neutral and unknown) including amplifying functional information (Intelligence, environmental, planning, routes, tracks, etc.) designed primarily to support a major warfare area.	Bi-SC NATO COP CONOPS (2001)
24	Security Domain for OPCIS		This edition of MC 640 suggests “secret” as the classification at the interoperability point between two National OPCIS implementations.	
25	Security Domain for TACCIS		This edition of MC 640 suggests “restricted” as the classification at the interoperability point between two National TACCIS implementations. Note that NATO allies have different classifications at the TACCIS layer in accordance with National policies. Where a National TACCIS system is operating at a higher confidentiality level, technical and content filtering measures might be required to tailor the service and information exchanged to “restricted”.	

NATO UNCLASSIFIED
DRAFT

ANNEX B TO
Draft MC 0640

No	Title/Subject	Abbreviation	Definition	Reference
26	Standards Based Interoperability		Standards based interoperability describes the concept of achieving interoperability by implementing the same technical and procedural standards on different systems, and thereby achieving interoperability that is based on the standards selected to implement services. The federation principles set forth in FMN are encouraging/enforcing standards based interoperability.	
27	Tactical CIS	TACCIS	Represents the mobile layer of tactical network and all its CIS elements, e.g. BG level and below. Interconnectivity is usually achieved using tactical narrowband or wideband radios. The OPCIS layer, due the bandwidth and security constraints, cannot be seamlessly integrated into the FMN mission network, but requires tailoring of services and information content due to the above constraints.	
28	Text-Based Collaboration		The text-based collaboration service provides the exchange of text-based messages via a CHAT protocol that enables multi-point text conversation in real time by allowing text entered at one site to be displayed within a session at other sites. Each site can enter text in the session. Exchange of text is maintained on a character-by-character or close to character-by-character basis in order to give the session participants an opportunity to exercise a natural conversation in text.	

NATO UNCLASSIFIED
DRAFT

ANNEX B TO
Draft MC 0640

No	Title/Subject	Abbreviation	Definition	Reference
29	Video-Based Collaboration		The video-based collaboration service provides a two-way simultaneous video transmission among two or more remote parties on the network, including call set-up, call co-ordination, full motion display of events and participants in a bi-directional manner, support for the management of directing the cameras, ranging from fixed position, to sender directed, to receiver directed, to automated sound pickup.	

IER SPECIFICATIONS**OVERVIEW**

1. This Annex provides detailed operational IERs for NATO-led land based operations, detailing both the deployment of VJTF(L) BDE within a VJTF(L) scenario and the deployment of a LCC with up to three subordinate Corps and multiple BDEs deployed in a MJO+ scenario.
2. The IERs within MC 0640 will complement the work conducted in MC 0593/1 and define the IERs required in the Land domain down to company level. The IERs contained within MC 0640 have been derived from NRF exercises planning and conduct, and determined in coordination with the GRF-L Corps, including those held at readiness in support of the NRF and those BDEs held at high readiness in support of the VJTF(L) and with reference to NATO doctrine, in particular Allied Joint Publications (AJPs).
3. Note that these IERs are not exhaustive as they are only addressing the minimum requirements.
4. The IERs that are contained within this Annex are:
 - a. VJTF(L) BDE C2,
 - b. VJTF (L) & MJO+ Intelligence,
 - c. VJTF (L) & MJO+ Fire Support,
 - d. VJTF (L) & MJO+ Air Support,
 - e. VJTF (L) & MJO+ Logistics Support,
 - f. VJTF (L) & MJO+ Medical,
 - g. Land C2 Entities to Non NATO Entities.
5. The following VJTF (L) & MJO+ IERs will follow in later editions of MC0640:
 - a. Air Defence,
 - b. Military Engineering,
 - c. Military Police,
 - d. CIMIC.

6. The aforementioned IERs will first be represented pictorially and then in a tabular format, each for a VJTF(L) and MJO+ scenario.

VJTF(L) BDE C2 IER

7. Specific C2 information product exchange for the VJTF(L) Standby BDE is depicted in Figure C-1. The unidirectional red arrows represent products sent from the VJTF(L) BDE to other C2 entities. The green unidirectional arrows represent information products sent to and consumed by the VJTF(L) BDE.

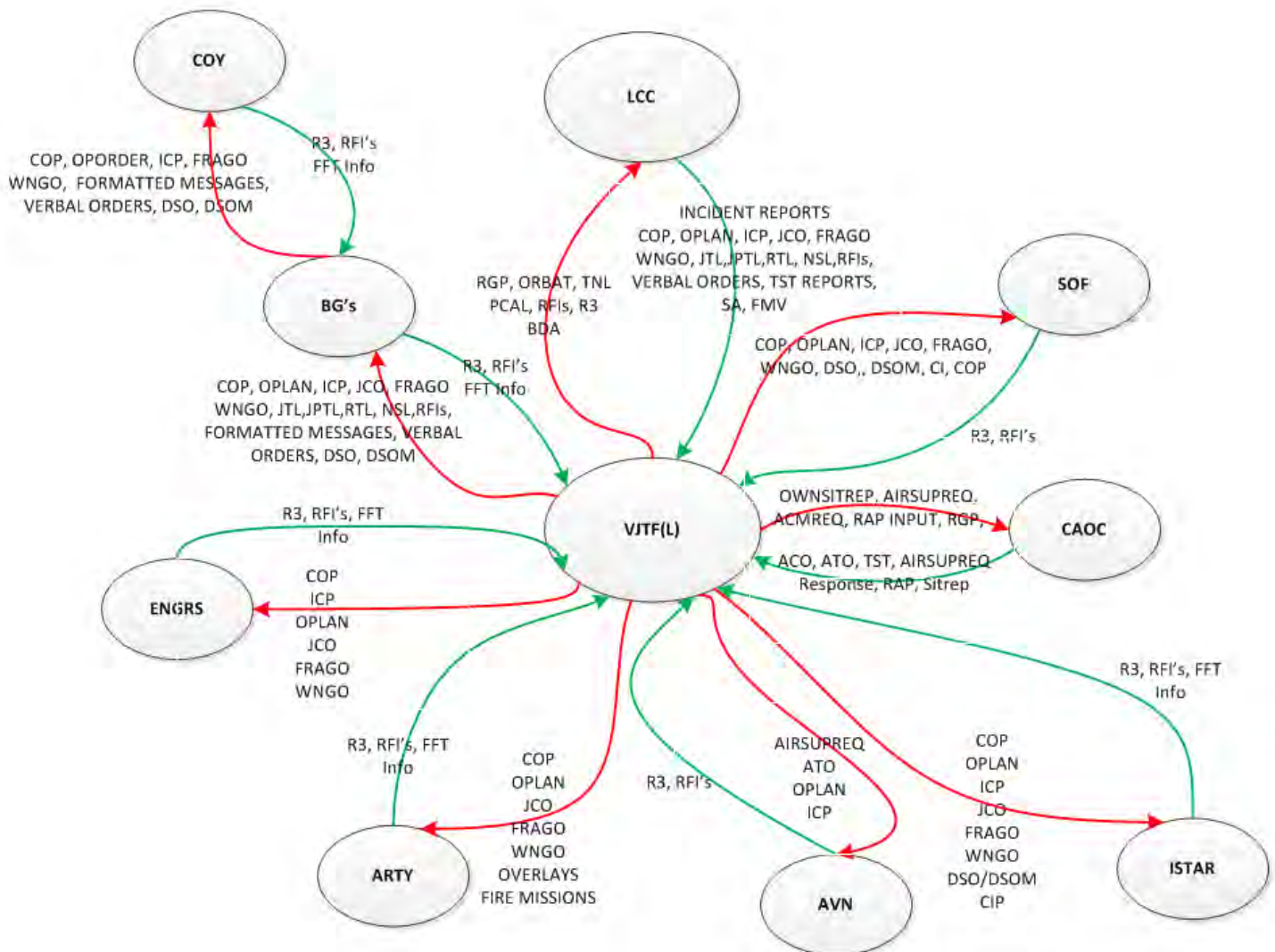

Figure C-1: VJTF(L) Standby BDE C2 Unidirectional Information Product Exchange

8. Figure C-2 depicts bi-directional product dissemination relating to the H2H services for the VJTF(L) BDE. The bi-directional black arrows represent products sent and consumed from the VJTF(L) BDE to other C2 entities.

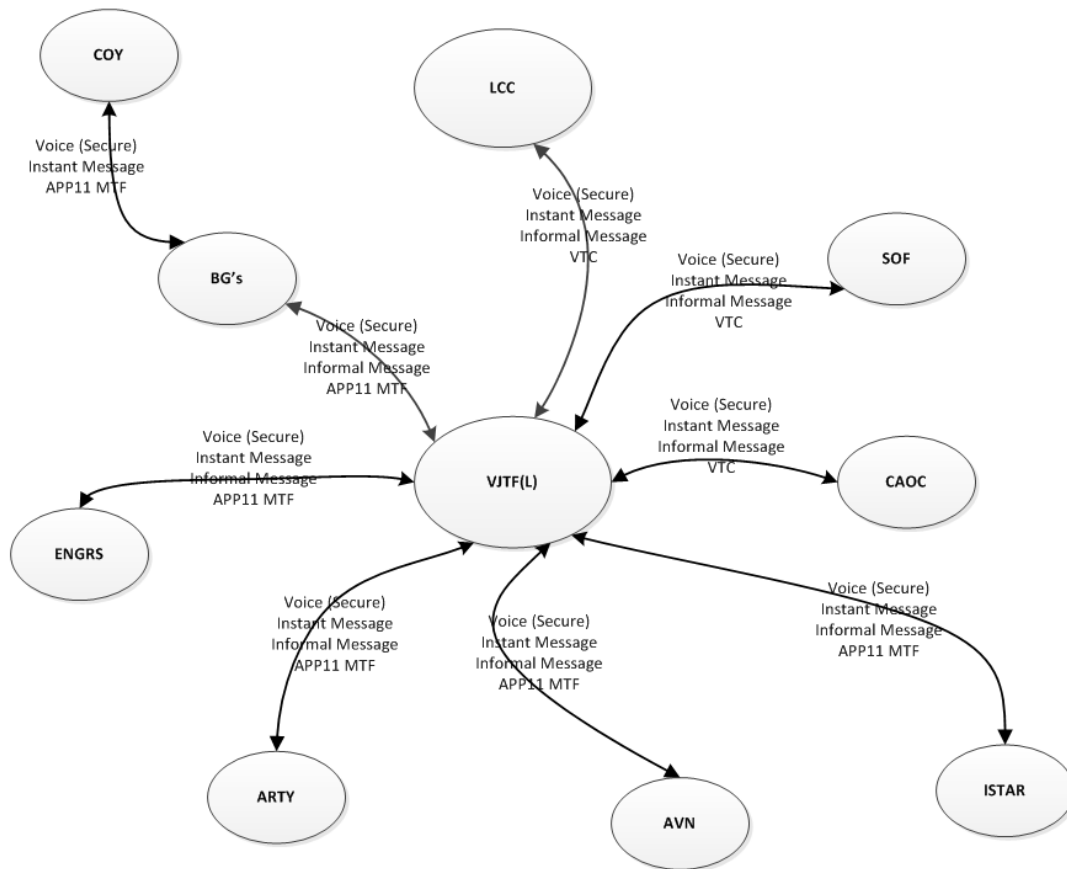

Figure C-2: VJTF(L) Standby *BDE* H2H Information Product Exchange

9. Depicted in the table C-1 are a representation (BDE to battle group/battle group to company) of the unidirectional and bi-directional products relating to the VJTF(L) BDE C2 information products as introduced in Figures C-1 and C-2. The column 'IER From' and 'IER To' details the C2 entities which the information products are exchanged with, the third column lists the product that is exchanged. Column 4 lists the operational capability that the product supports and columns 5 - 6 map the product to the service type as detailed in the C3 taxonomy nomenclature:

IER From	IER To	IE Product	User Service Definition Operational Capability	Technical Service Level 2	Technical Service Level 1
LAND COMPONENT COMMAND (LCC) - VERY HIGH READINESS JOINT TASK FORCE (LAND) (VJTF(L))					
LCC	VJTF(L)	INCIDENT REPORTS	Reports	Tasking and Order Services	
LCC	VJTF(L)	COP	Recognized Picture Services	Situation Awareness Services	COI Services
LCC	VJTF(L)	OPLAN	Plans	Tasking and Order Services	COI Services
LCC	VJTF(L)	ICP	Requests and Responses	JISR Services	COI Services
LCC	VJTF(L)	JCO	Tasking and Orders	Joint Services	COI Services
LCC	VJTF(L)	FRAGO	Tasking and Orders	Tasking and Order Services	COI Enabling Services
LCC	VJTF(L)	WNGO	Tasking and Orders	Tasking and Order Services	COI Enabling Services
LCC	VJTF(L)	JTL	Joint Targeting	JISR Services	COI Services
LCC	VJTF(L)	JPTL	Joint Targeting	JISR Services	COI Services
LCC	VJTF(L)	RTL	Joint Targeting	Operation Planning Services	COI Enabling Services
LCC	VJTF(L)	NSL	Joint Targeting	Operation Planning Services	COI Enabling Services
LCC	VJTF(L)	Verbal Orders	Tasking and Orders	Tasking and Order Services	COI Enabling Services
LCC	VJTF(L)	TST Reports	Time Sensitive Targeting	Operation Planning Services	COI Enabling Services
LCC	VJTF(L)	Situational Awareness	Situational Awareness	Situation Awareness Services	COI Enabling Services

NATO UNCLASSIFIED
DRAFT

ANNEX C TO
 Draft MC 0640

IER From	IER To	IE Product	User Service Definition Operational Capability	Technical Service Level 2	Technical Service Level 1
LCC	VJTF(L)	Full Motion Video	JISR Imagery and Video Services	JISR Services	COI Services
VJTF(L)	LCC	RGP	Recognized Ground Picture Services	Land Services	COI Services
VJTF(L)	LCC	ORBAT	Order of Battle Services	Operation Planning Services	COI Enabling Services
VJTF(L)	LCC	TNL	Joint Targeting	Operation Planning Services	COI Enabling Services
VJTF(L)	LCC	PCAL	Joint Targeting	Operation Planning Services	COI Enabling Services
VJTF(L)	LCC	R3 Reporting	Reports	Tasking and Order Services	COI Enabling Services
VJTF(L)	LCC	BDA	Reports	Tasking and Order Services	COI Enabling Services
BI-DIRECTIONAL					
HUMAN-TO-HUMAN					
LCC	VJTF(L)	Voice (Secure)	Voice	Audio-Based Communication Services	Core Services
LCC	VJTF(L)	Informal Message	Informal Messaging	Informal Messaging Services	Core Services
LCC	VJTF(L)	Instant Message	Instant Messaging	Text-Based Collaboration Services	Core Services
LCC	VJTF(L)	VTC	VTC	Video Based Collaboration Services	Core Services

NATO UNCLASSIFIED
DRAFT

ANNEX C TO
 Draft MC 0640

IER From	IER To	IE Product	User Service Definition Operational Capability	Technical Service Level 2	Technical Service Level 1
BI-DIRECTIONAL					
LCC	VJTF(L)	RFI	Requests and Responses	Operation Planning Services	COI Services
VJTF(L) - SPECIAL OPERATIONS FORCE (SOF)					
VJTF(L)	SOF	COP	Recognized Picture Services	Situation Awareness Services	COI Enabling Services
VJTF(L)	SOF	OPLAN	Plans	Tasking and Order Services	COI Enabling Services
VJTF(L)	SOF	ICP	Requests and Responses	JISR Services	COI Services
VJTF(L)	SOF	JCO	Tasking and Orders	Joint Services	COI Services
VJTF(L)	SOF	FRAGO	Tasking and Orders	Tasking and Order Services	COI Enabling Services
VJTF(L)	SOF	WNGO	Tasking and Orders	Tasking and Order Services	COI Enabling Services
VJTF(L)	SOF	DSO	Synchronization Matrix Services	Operation Planning Services	COI Enabling Services
VJTF(L)	SOF	DSOM	Synchronization Matrix Services	Operation Planning Services	COI Enabling Services
VJTF(L)	SOF	CI	JISR Exploitation Services	JISR Services	COI Services
VJTF(L)	SOF	COP	Recognized Picture Services	Situation Awareness Services	COI Enabling Services
SOF	VJTF(L)	R3 Reporting	Reports	Tasking and Order Services	COI Enabling Services
SOF	VJTF(L)	RFI	Requests and Responses	Operation Planning Services	COI Services

IER From	IER To	IE Product	User Service Definition Operational Capability	Technical Service Level 2	Technical Service Level 1
BI-DIRECTIONAL					
HUMAN-TO-HUMAN					
VJTF(L)	SOF	Voice (Secure)	Voice	Audio-Based Communication Services	Core Services
VJTF(L)	SOF	Informal Message	Informal Messaging	Informal Messaging Services	Core Services
VJTF(L)	SOF	Instant Message	Instant Messaging	Text-Based Collaboration Services	Core Services
VJTF(L)	SOF	VTC	VTC	Video Based Collaboration Services	Core Services
VJTF(L) - COMBINED AIR OPERATIONS CENTRE					
VJTF(L)	CAOC	OWNSITREP	Reports	Tasking and Order Services	COI Enabling Services
VJTF(L)	CAOC	AIRSUPREQ	Requests and Responses	Air Services	COI Services
VJTF(L)	CAOC	ACMREQ	Requests and Responses	Joint Services	COI Services
VJTF(L)	CAOC	RAP Input	Recognized Air Picture Services	Air Services	COI Services
VJTF(L)	CAOC	RGP	Recognized Ground Picture Services	Land Services	COI Services
CAOC	VJTF(L)	ACO	ACO Services	Air Services	COI Services
CAOC	VJTF(L)	ATO	Air Tasking Order Services	Air Services	COI Services
CAOC	VJTF(L)	TST	Targeting Services	Operation Planning Services	COI Services
CAOC	VJTF(L)	AIRSUPREQ Response	Air Tasking Order Services	Air Services	COI Services

NATO UNCLASSIFIED
DRAFT

ANNEX C TO
 Draft MC 0640

IER From	IER To	IE Product	User Service Definition Operational Capability	Technical Service Level 2	Technical Service Level 1
CAOC	VJTF(L)	RAP	Recognized Air Picture Services	Air Services	COI Services
CAOC	VJTF(L)	SITREP	Reports	Tasking and Order Services	COI Enabling Services
BI-DIRECTIONAL					
HUMAN-TO-HUMAN					
VJTF(L)	CAOC	Voice (Secure)	Voice	Audio-Based Communication Services	Core Services
VJTF(L)	CAOC	Informal Message	Informal Messaging	Informal Messaging Services	Core Services
VJTF(L)	CAOC	Instant Message	Instant Messaging	Text-Based Collaboration Services	Core Services
VJTF(L)	CAOC	VTC	VTC	Video Based Collaboration Services	Core Services
VJTF(L) - INTELLIGENCE SURVEILLANCE TARGET ACQUISITION RECONNAISSANCE GROUPING (ISTAR)					
VJTF(L)	ISTAR	COP	Recognized Picture Services	Situation Awareness Services	COI Services
VJTF(L)	ISTAR	OPLAN	Plans	Tasking and Order Services	COI Services
VJTF(L)	ISTAR	ICP	Requests and Responses	JISR Services	COI Services
VJTF(L)	ISTAR	JCO	Tasking and Orders	Joint Services	COI Services
VJTF(L)	ISTAR	FRAGO	Tasking and Orders	Tasking and Order Services	COI Services
VJTF(L)	ISTAR	WNGO	Tasking and Orders	Tasking and Order Services	COI Services

IER From	IER To	IE Product	User Service Definition Operational Capability	Technical Service Level 2	Technical Service Level 1
VJTf(L)	ISTAR	DSO	Synchronization Matrix Services	Operation Planning Services	COI Enabling Services
VJTf(L)	ISTAR	DSOM	Synchronization Matrix Services	Operation Planning Services	COI Enabling Services
VJTf(L)	ISTAR	CIP	Recognized Picture Services	Situation Awareness Services	COI Services
ISTAR	VJTf(L)	R3 Reporting	Reports	Tasking and Order Services	COI Enabling Services
ISTAR	VJTf(L)	RFI's	Requests and Responses	Operation Planning Services	COI Services
ISTAR	VJTf(L)	FFT Info	Track Services	Battlespace Information Services	COI Services
BI-DIRECTIONAL					
HUMAN-TO-HUMAN					
VJTf(L)	ISTAR	Voice (Secure)	Voice	Audio-Based Communication Services	Core Services
VJTf(L)	ISTAR	Instant Message	Instant Messaging	Text-Based Collaboration Services	Core Services
VJTf(L)	ISTAR	Informal Message	Informal Messaging	Informal Messaging Services	Core Services
VJTf(L)	ISTAR	APP11 MTF	Military Messaging Services	Unified Communication & Collaboration Services	Core Services
VJTf(L) - AVIATION GROUPING (AVN GP)					
VJTf(L)	AVN GP	AIRSUPREQ	Requests and Responses	Air Services	COI Services
VJTf(L)	AVN GP	ATO	Tasking and Orders	Air Services	COI Services

NATO UNCLASSIFIED
DRAFT

ANNEX C TO
 Draft MC 0640

IER From	IER To	IE Product	User Service Definition Operational Capability	Technical Service Level 2	Technical Service Level 1
VJTf(L)	AVN GP	OPLAN	Plans	Tasking and Order Services	COI Services
VJTf(L)	AVN GP	ICP	Plans	JISR Services	COI Services
AVN GP	VJTf(L)	R3 Reporting	Reports	Tasking and Order Services	COI Enabling Services
AVN GP	VJTf(L)	RFI's	Requests and Responses	Operation Planning Services	COI Services
BI-DIRECTIONAL					
HUMAN-TO-HUMAN					
VJTf(L)	AVN GP	Voice (Secure)	Voice	Audio-Based Communication Services	Core Services
VJTf(L)	AVN GP	Instant Message	Instant Messaging	Text-Based Collaboration Services	Core Services
VJTf(L)	AVN GP	Informal Message	Informal Messaging	Informal Messaging Services	Core Services
VJTf(L)	AVN GP	APP11 MTF	Military Messaging Services	Unified Communication & Collaboration Services	Core Services
VJTf(L) - FIRE SUPPORT GROUPING (FS GP)					
VJTf(L)	FS GP	COP	Recognized Picture Services	Situation Awareness Services	COI Services
VJTf(L)	FS GP	OPLAN	Plans	Tasking and Order Services	COI Services
VJTf(L)	FS GP	JCO	Tasking and Orders	Joint Services	COI Services
VJTf(L)	FS GP	FRAGO	Tasking and Orders	Tasking and Order Services	COI Services

NATO UNCLASSIFIED
DRAFT

ANNEX C TO
 Draft MC 0640

IER From	IER To	IE Product	User Service Definition Operational Capability	Technical Service Level 2	Technical Service Level 1
VJTf(L)	FS GP	WNGO	Tasking and Orders	Tasking and Order Services	COI Services
VJTf(L)	FS GP	Overlays	Operations Order Services	Tasking and Order Services	COI Services
VJTf(L)	FS GP	Fire Missions	Targeting Services	Operation Planning Services	COI Enabling Services
FS GP	VJTf(L)	R3 Reporting	Reports	Tasking and Order Services	COI Enabling Services
FS GP	VJTf(L)	RFI's	Requests and Responses	Operation Planning Services	COI Services
FS GP	VJTf(L)	FFT Info	Track Services	Battlespace Information Services	COI Services
BI-DIRECTIONAL					
HUMAN-TO-HUMAN					
VJTf(L)	FS GP	Voice (Secure)	Voice	Audio-Based Communication Services	Core Services
VJTf(L)	FS GP	Instant Message	Instant Messaging	Text-Based Collaboration Services	Core Services
VJTf(L)	FS GP	Informal Message	Informal Messaging	Informal Messaging Services	Core Services
VJTf(L)	FS GP	APP11 MTF	Military Messaging Services	Unified Communication & Collaboration Services	Core Services
VJTf(L) - ENGINEER GROUPING (ENGR GP)					
VJTf(L)	ENGR GP	COP	Recognized Picture Services	Situation Awareness Services	COI Services
VJTf(L)	ENGR GP	ICP	Plans	JISR Services	COI Services

NATO UNCLASSIFIED
DRAFT

ANNEX C TO
 Draft MC 0640

IER From	IER To	IE Product	User Service Definition Operational Capability	Technical Service Level 2	Technical Service Level 1
VJTF(L)	ENGR GP	OPLAN	Tasking and Orders	Tasking and Order Services	COI Services
VJTF(L)	ENGR GP	JCO	Tasking and Orders	Joint Services	COI Services
VJTF(L)	ENGR GP	FRAGO	Tasking and Orders	Tasking and Order Services	COI Services
VJTF(L)	ENGR GP	WNGO	Tasking and Orders	Tasking and Order Services	COI Services
ENGR GP	VJTF(L)	R3 Reporting	Reports	Tasking and Order Services	COI Enabling Services
ENGR GP	VJTF(L)	RFI's	Requests and Responses	Operation Planning Services	COI Services
ENGR GP	VJTF(L)	FFT Info	Track Services	Battlespace Information Services	COI Services
BI-DIRECTIONAL					
HUMAN-TO-HUMAN					
VJTF(L)	ENGR GP	Voice (Secure)	Voice	Audio-Based Communication Services	Core Services
VJTF(L)	ENGR GP	Instant Message	Instant Messaging	Text-Based Collaboration Services	Core Services
VJTF(L)	ENGR GP	Informal Message	Informal Messaging	Informal Messaging Services	Core Services
VJTF(L)	ENGR GP	APP11 MTF	Military Messaging Services	Unified Communication & Collaboration Services	Core Services
VJTF(L) - BATTLE GROUPS (BG)					
VJTF(L)	BG	COP	Recognized Picture Services	Situation Awareness Services	COI Services

NATO UNCLASSIFIED
DRAFT

ANNEX C TO
 Draft MC 0640

IER From	IER To	IE Product	User Service Definition Operational Capability	Technical Service Level 2	Technical Service Level 1
VJTf(L)	BG	OPLAN	Tasking and Orders	Tasking and Order Services	COI Services
VJTf(L)	BG	ICP	Plans	JISR Services	COI Services
VJTf(L)	BG	JCO	Tasking and Orders	Joint Services	COI Services
VJTf(L)	BG	FRAGO	Tasking and Orders	Tasking and Order Services	COI Services
VJTf(L)	BG	WNGO	Tasking and Orders	Tasking and Order Services	COI Services
VJTf(L)	BG	JTL	Joint Targeting	JISR Services	COI Services
VJTf(L)	BG	JPTL	Joint Targeting	JISR Services	COI Services
VJTf(L)	BG	RTL	Joint Targeting	Operation Planning Services	COI Services
VJTf(L)	BG	NSL	Joint Targeting	Operation Planning Services	COI Services
VJTf(L)	BG	RFI's	Requests and Responses	Operation Planning Services	COI Services
VJTf(L)	BG	Verbal Orders	Tasking and Orders	Tasking and Order Services	COI Services
VJTf(L)	BG	DSO	Synchronization Matrix Services	Operation Planning Services	COI Enabling Services
VJTf(L)	BG	DSOM	Synchronization Matrix Services	Operation Planning Services	COI Enabling Services
BG	VJTf(L)	R3 Reporting	Reports	Tasking and Order Services	COI Enabling Services
BG	VJTf(L)	RFI's	Requests and Responses	Operation Planning Services	COI Services

NATO UNCLASSIFIED
DRAFT

ANNEX C TO
Draft MC 0640

IER From	IER To	IE Product	User Service Definition Operational Capability	Technical Service Level 2	Technical Service Level 1
BG	VJTF(L)	FFT Info	Track Services	Battlespace Information Services	COI Services
BI-DIRECTIONAL HUMAN-TO-HUMAN					
VJTF(L)	BG	Voice (Secure)	Voice	Audio-Based Communication Services	Core Services
VJTF(L)	BG	Instant Message	Instant Messaging	Text-Based Collaboration Services	Core Services
VJTF(L)	BG	Informal Message	Informal Messaging	Informal Messaging Services	Core Services
VJTF(L)	BG	APP11 MTF	Military Messaging Services	Unified Communication & Collaboration Services	Core Services
BATTLE GROUPS (BG) - COMPANY (COY)					
BG	COY	COP	Recognized Picture Services	Situation Awareness Services	COI Services
BG	COY	OPORDER	Tasking and Orders	Tasking and Order Services	COI Services
BG	COY	ICP	Plans	JISR Services	COI Services
BG	COY	FRAGO	Tasking and Orders	Tasking and Order Services	COI Services
BG	COY	WNGO	Tasking and Orders	Tasking and Order Services	COI Services
BG	COY	DSO	Synchronization Matrix Services	Operation Planning Services	COI Enabling Services
BG	COY	DSOM	Synchronization Matrix Services	Operation Planning Services	COI Enabling Services

NATO UNCLASSIFIED
DRAFT

ANNEX C TO
 Draft MC 0640

IER From	IER To	IE Product	User Service Definition Operational Capability	Technical Service Level 2	Technical Service Level 1
BG	COY	Verbal Orders	Tasking and Orders	Tasking and Order Services	COI Services
COY	BG	FFT Info	Track Services	Battlespace Information Services	COI Services
COY	BG	R3 Reporting	Reports	Tasking and Order Services	COI Enabling Services
COY	BG	RFI's	Requests and Responses	Operation Planning Services	COI Services
BI-DIRECTIONAL					
HUMAN-TO-HUMAN					
BG	COY	Voice (Secure)	Voice	Audio-Based Communication Services	Core Services
BG	COY	Instant Message	Instant Messaging	Text-Based Collaboration Services	Core Services
BG	COY	Formatted Message	Military Messaging Services	Unified Communication & Collaboration Services	Core Services

Table C-1: VJTf(L) BDE to COY C2 Product Dissemination and Consumption

VJTF(L) INTELLIGENCE IER

10. Specific H2H and systems information product exchange to enable the effective collection, exploitation, dissemination and receipt of intelligence product in the land environment during a VJTF(L) scenario is depicted in Figure C-3. The unidirectional red and green arrows represent products either consumed or disseminated from intelligence entities within the land environment. The bi-directional black arrows represent products that are both disseminated and consumed by land based intelligence entities.

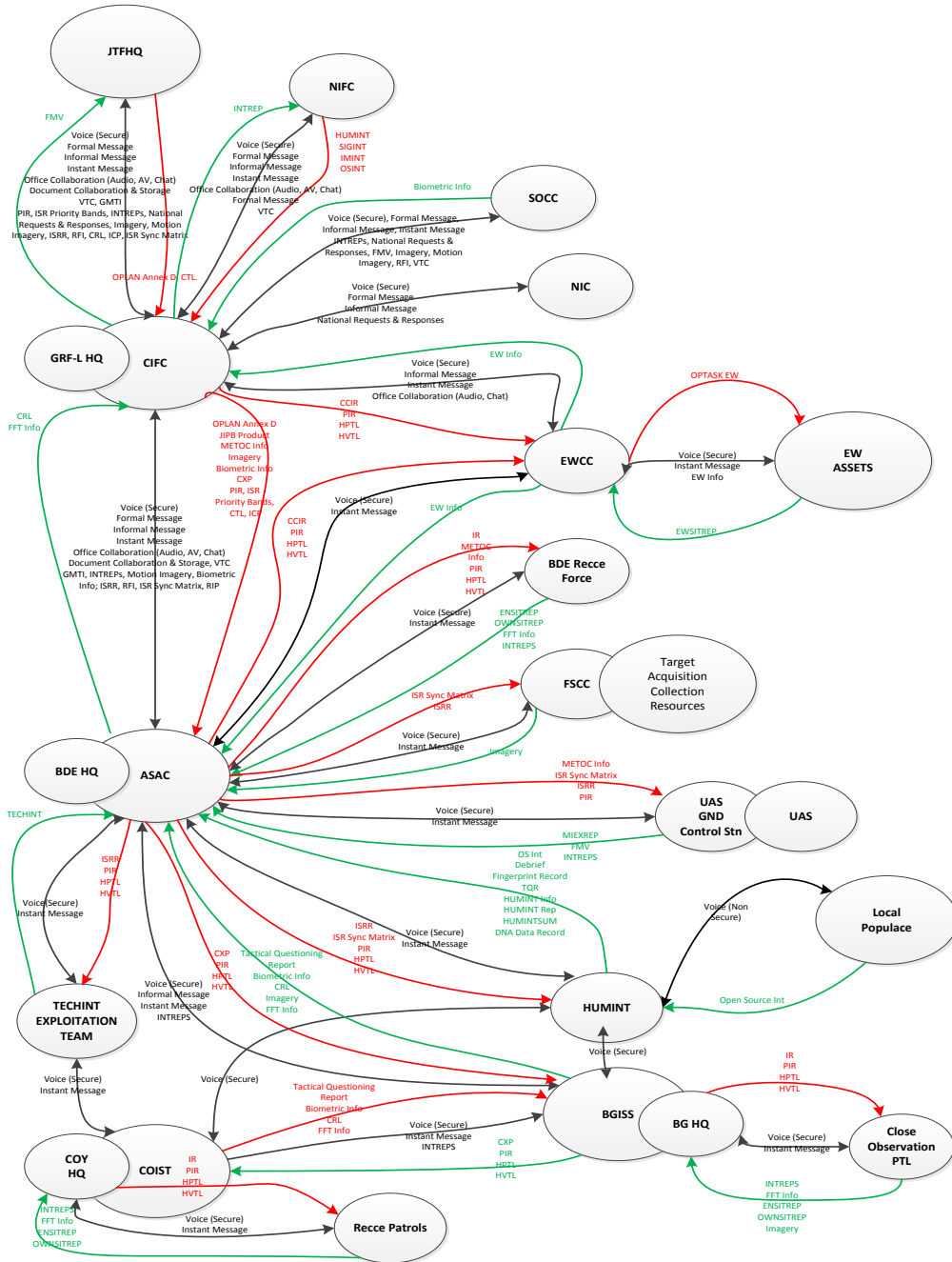

Figure C-3: VJTF(L) BDE Intelligence Product Dissemination/Consumption

11. As introduced in Figure C-3, the products depicted in the table C-2 details the unidirectional and bi-directional products relating to the intelligence process within a land environment under a VJTF(L) scenario. The column 'IER From' and 'IER To' details the C2 entities which the information products are exchanged with, the third column lists the product that is exchanged. Column 4 lists the operational capability that the product supports and columns 5 - 6 map the product to the service type as detailed in the C3 Taxonomy nomenclature:

IER From	IER To	IE Product	User Service Definition Operational Capability	Technical Service Level 2	Technical Service Level 1
JOINT TASK FORCE HEADQUARTERS (JTF HQ) - CORPS INTELLIGENCE FUSION CELL (CIFC)					
JTF HQ	CIFC	OPLAN Annex D	Plans	Joint Services	COI Services
JTF HQ	CIFC	CTL	Tasking & Orders	JISR Services	COI Services
CIFC	JTF HQ	FMV	Full Motion Video	JISR Services	COI Services
BI-DIRECTIONAL					
JTF HQ	CIFC	Voice (Secure)	Voice	Audio-Based Communication Services	Core Services
JTF HQ	CIFC	Formal Message	Formal Messaging	Military Messaging Service	Core Services
JTF HQ	CIFC	Informal Message	Informal Messaging	Informal Messaging Services	Core Services
JTF HQ	CIFC	Instant Message	Instant Messaging	Text-Based Collaboration Services	Core Services
JTF HQ	CIFC	Office Collaboration (Audio)	Collaboration	Audio-Based Communication Services	Core Services

IER From	IER To	IE Product	User Service Definition Operational Capability	Technical Service Level 2	Technical Service Level 1
JTF HQ	CIFC	Office Collaboration (AV)	Collaboration	Video-Based Communication Services	Core Services
JTF HQ	CIFC	Office Collaboration (Chat)	Collaboration	Text-Based Collaboration Services	Core Services
JTF HQ	CIFC	VTC	VTC	Video Based Collaboration Services	Core Services
JTF HQ	CIFC	GMTI	VTC	Video Based Collaboration Services	Core Services
JTF HQ	CIFC	PIR	Tasking & Orders	JISR Services	COI Services
JTF HQ	CIFC	ISR Priority Bands	Tasking & Orders	JISR Services	COI Services
JTF HQ	CIFC	INTREPS	Reports	JISR Services	COI Services
JTF HQ	CIFC	National Requests & Responses	Requests & Responses	JISR Services	COI Services
JTF HQ	CIFC	Imagery	Intel Database Services	JISR Services	COI Services
JTF HQ	CIFC	Motion Imagery	Intel Database Services	JISR Services	COI Services
JTF HQ	CIFC	ISRR	Requests & Responses	JISR Services	COI Services
JTF HQ	CIFC	RFI	Requests & Responses	JISR Services	COI Services
JTF HQ	CIFC	CRL	Requests & Responses	JISR Services	COI Services
JTF HQ	CIFC	ICP	Plans	JISR Services	COI Services
JTF HQ	CIFC	ISR Sync Matrix	Plans	JISR Services	COI Services
CORPS INTELLIGENCE FUSION CELL (CIFC) - SPECIAL OPERATIONS COMPONENT COMMAND					
SOCC	CIFC	Biometric Info	Reports	JISR Services	COI Services

IER From	IER To	IE Product	User Service Definition Operational Capability	Technical Service Level 2	Technical Service Level 1
BI-DIRECTIONAL					
CIFC	SOCC	Voice (Secure)	Voice	Audio-Based Communication Services	Core Services
CIFC	SOCC	Formal Message	Formal Messaging	Military Messaging Service	Core Services
CIFC	SOCC	Informal Message	Informal Messaging	Informal Messaging Services	Core Services
CIFC	SOCC	Instant Message	Instant Messaging	Text-Based Collaboration Services	Core Services
CIFC	SOCC	VTC	VTC	Video Based Collaboration Services	Core Services
CIFC	SOCC	INTREPS	Reports	JISR Services	COI Services
CIFC	SOCC	GMTI	VTC	Video Based Collaboration Services	Core Services
CIFC	SOCC	National Requests & Responses	Requests & Responses	JISR Services	COI Services
CIFC	SOCC	FMV	JISR Imagery and Video Services	JISR Services	COI Services
CIFC	SOCC	Imagery	Intel Database Services	JISR Services	COI Services
CIFC	SOCC	Motion Imagery	Intel Database Services	JISR Services	COI Services
CIFC	SOCC	RFI	Requests & Responses	JISR Services	COI Services

IER From	IER To	IE Product	User Service Definition Operational Capability	Technical Service Level 2	Technical Service Level 1
CORPS INTELLIGENCE FUSION CELL(CIFC) - BDE ALL SOURCES ANALYSIS CELL (ASAC)					
CIFC	Bde ASAC	JIPB Product	Plans	JISR Services	COI Services
CIFC	Bde ASAC	METOC Info	METEO	Environmental Services	COI Services
CIFC	Bde ASAC	Imagery	Intel Database Services	JISR Services	COI Services
CIFC	Bde ASAC	Collection & Exploitation Plan (CXP)	Plans	Joint Services	COI Services
CIFC	Bde ASAC	OPLAN Annex D	Operation Order Services	Tasking and Order Services	COI Services
CIFC	Bde ASAC	PIR	Tasking & Orders	JISR Services	COI Services
CIFC	Bde ASAC	ISR Priority Bands	Tasking & Orders	JISR Services	COI Services
CIFC	Bde ASAC	CTL	Tasking & Orders	JISR Services	COI Services
CIFC	Bde ASAC	ICP	Plans	JISR Services	COI Services
Bde ASAC	CIFC	CRL	Requests & Responses	JISR Services	COI Services
Bde ASAC	CIFC	FFT Info	Live Tracks	Battlespace Information Services	COI Services
BI-DIRECTIONAL					
CIFC	Bde ASAC	Voice (Secure)	Voice	Audio-Based Communication Services	Core Services
CIFC	Bde ASAC	Formal Message	Formal Messaging	Military Messaging Service	Core Services
CIFC	Bde ASAC	Informal Message	Informal Messaging	Informal Messaging Services	Core Services

IER From	IER To	IE Product	User Service Definition Operational Capability	Technical Service Level 2	Technical Service Level 1
CIFC	Bde ASAC	Instant Message	Instant Messaging	Text-Based Collaboration Services	Core Services
CIFC	Bde ASAC	Office Collaboration (Audio)	Collaboration	Audio-Based Communication Services	Core Services
CIFC	Bde ASAC	Office Collaboration (AV)	Collaboration	Video-Based Communication Services	Core Services
CIFC	Bde ASAC	Office Collaboration (Chat)	Collaboration	Text-Based Collaboration Services	Core Services
CIFC	Bde ASAC	Document Collaboration & Storage	Information Mgt	Content Management Services	Core Services
CIFC	Bde ASAC	VTC	VTC	Video Based Collaboration Services	Core Services
CIFC	Bde ASAC	RIP	Situational Awareness	JISR Services	COI Services
CIFC	Bde ASAC	GMTI	Situational Awareness	JISR Services	Core Services
CIFC	Bde ASAC	INTREPS	Reports	JISR Services	COI Services
CIFC	Bde ASAC	Motion Imagery	Intel Database Services	JISR Services	COI Services
CIFC	Bde ASAC	GMTI	VTC	Video Based Collaboration Services	Core Services
CIFC	Bde ASAC	Biometric Info	Reports	JISR Services	COI Services

IER From	IER To	IE Product	User Service Definition Operational Capability	Technical Service Level 2	Technical Service Level 1
CIFC	Bde ASAC	ISRR	Requests & Responses	JISR Services	COI Services
CIFC	Bde ASAC	RFI	Requests & Responses	JISR Services	COI Services
CIFC	Bde ASAC	ISR Sync Matrix	Plans	JISR Services	COI Services
CORPS INTELLIGENCE FUSION CELL(CIFC) - NATIONAL INTELLIGENCE CELL (NIC)					
BI-DIRECTIONAL					
CIFC	NIC	Voice (Secure)	Voice	Audio-Based Communication Services	Core Services
CIFC	NIC	Formal Message	Formal Messaging	Military Messaging Service	Core Services
CIFC	NIC	Informal Message	Informal Messaging	Informal Messaging Services	Core Services
CIFC	NIC	National Requests & Responses	Requests & Responses	JISR Services	COI Services
CORPS INTELLIGENCE FUSION CENTRE (CIFC) ELECTRONIC WARFARE COORDINATION CELL (EWCC)					
CIFC	EWCC	CCIR	Tasking & Orders	JISR Services	COI Services
CIFC	EWCC	PIR	Tasking & Orders	JISR Services	COI Services
CIFC	EWCC	HPTL	Requests & Responses	JISR Services	COI Services
CIFC	EWCC	HVTL	Requests & Responses	JISR Services	COI Services
EWCC	CIFC	EW Info	Reports	EW Services	COI Services
BI-DIRECTIONAL					
CIFC	EWCC	Voice (Secure)	Voice	Audio-Based Communication Services	Core Services
CIFC	EWCC	Informal Message	Informal Messaging	Informal Messaging Services	Core Services

IER From	IER To	IE Product	User Service Definition Operational Capability	Technical Service Level 2	Technical Service Level 1
CIFC	EWCC	Instant Message	Instant Messaging	Text-Based Collaboration Services	Core Services
CIFC	EWCC	Office Collaboration (Audio)	Collaboration	Audio-Based Communication Services	Core Services
CIFC	EWCC	Office Collaboration (Chat)	Collaboration	Text-Based Collaboration Services	Core Services
CIFC	EWCC	Document Collaboration & Storage	Information Management	Content Management Services	Core Services
BRIGADE ALL SOURCES ANALYSIS CELL (BDE ASAC) - ELECTRONIC WARFARE COORDINATION CELL (EWCC)					
BDE ASAC	EWCC	CCIR	Tasking & Orders	JISR Services	COI Services
BDE ASAC	EWCC	PIR	Tasking & Orders	JISR Services	COI Services
BDE ASAC	EWCC	HPTL	Requests & Responses	JISR Services	COI Services
BDE ASAC	EWCC	HVTL	Requests & Responses	JISR Services	COI Services
EWCC	Bde ASAC	EW Info	Reports	EW Services	COI Services
BI-DIRECTIONAL					
BDE ASAC	EWCC	Voice (Secure)	Voice	Audio-Based Communication Services	Core Services
BDE ASAC	EWCC	Instant Message	Instant Messaging	Text-Based Collaboration Services	COI Services

IER From	IER To	IE Product	User Service Definition Operational Capability	Technical Service Level 2	Technical Service Level 1
ELECTRONIC WARFARE COORDINATION CELL (EWCC) - ELECTRONIC WARFARE ASSETS (EW ASSETS)					
EWCC	EW ASSETS	OPTASK EW	Tasking & Orders	EW Services	COI Services
EW ASSETS	EWCC	EW SITREP	Reports	EW Services	COI Services
EW ASSETS	EWCC	RFL	Reports	EW Services	COI Services
EW ASSETS	EWCC	GMTI	VTC	Video Based Collaboration Services	Core Services
BI-DIRECTIONAL					
EWCC	EW ASSETS	Voice (Secure)	Voice	Audio-Based Communication Services	Core Services
EWCC	EW ASSETS	Instant Message	Instant Messaging	Text-Based Collaboration Services	Core Services
EW ASSETS	EWCC	EW Info	Reports	EW Services	COI Services
BRIGADE ALL SOURCES ANALYSIS CELL (Bde ASAC) - BDE RECONNAISSANCE FORCE (Bde Recce Force)					
Bde ASAC	Bde Recce Force	IR	Tasking & Orders	JISR Services	COI Services
Bde ASAC	Bde Recce Force	METOC Info	Reports	JISR Services	COI Services
Bde ASAC	Bde Recce Force	PIR	Tasking & Orders	JISR Services	COI Services
Bde ASAC	Bde Recce Force	HPTL	Requests & Responses	JISR Services	COI Services

IER From	IER To	IE Product	User Service Definition Operational Capability	Technical Service Level 2	Technical Service Level 1
Bde ASAC	Bde Recce Force	HVTL	Requests & Responses	JISR Services	COI Services
Bde Recce Force	Bde ASAC	ENSITREP	Operations Assessment Services	Tasking and Order Services	COI Services
Bde Recce Force	Bde ASAC	OWNSITREP	Operations Assessment Services	Tasking and Order Services	COI Services
Bde Recce Force	Bde ASAC	FFT Info	Live Tracks	Battlespace Information Services	COI Services
Bde Recce Force	Bde ASAC	INTREPS	Reports	JISR Services	COI Services
BI-DIRECTIONAL					
Bde ASAC	Bde Recce Force	Voice (Secure)	Voice	Audio-Based Communication Services	Core Services
Bde ASAC	Bde Recce Force	Instant Message	Instant Messaging	Text-Based Collaboration Services	Core Services
BDE ASAC - FSCC					
Bde ASAC	FSCC	ISR Sync Matrix	Plans	JISR Services	COI Services
Bde ASAC	FSCC	ISRR	JISR Imagery and Video Services	JISR Services	COI Services
FSCC	Bde ASAC	Imagery	Intel Database Services	JISR Services	COI Services
BI-DIRECTIONAL					
Bde ASAC	FSCC	Voice (Secure)	Voice	Audio-Based Communication Services	Core Services

NATO UNCLASSIFIED
DRAFT

ANNEX C TO
 Draft MC 0640

IER From	IER To	IE Product	User Service Definition Operational Capability	Technical Service Level 2	Technical Service Level 1
Bde ASAC	FSCC	Instant Message	Instant Messaging	Text-Based Collaboration Services	Core Services
BRIGADE ALL SOURCES ANALYSIS CELL (Bde ASAC) - UNMANNED ARIEL SURVEILLANCE GROUND CONTROL STATION (UAS Gnd Control Stn)					
Bde ASAC	UAS Gnd Control Station	METOC Info	Reports	JISR Services	COI Services
Bde ASAC	UAS Gnd Control Station	ISR Sync Matrix	Plans	JISR Services	COI Services
Bde ASAC	UAS Gnd Control Station	ISRR	Requests & Responses	JISR Services	COI Services
Bde ASAC	UAS Gnd Control Station	PIR	Tasking & Orders	JISR Services	COI Services
UAS Gnd Control Station	Bde ASAC	MIEXREP	Reports	JISR Services	COI Services
UAS Gnd Control Station	Bde ASAC	FMV	Full Motion Video	JISR Services	COI Services
UAS Gnd Control Station	Bde ASAC	INTREPS	Reports	JISR Services	COI Services

IER From	IER To	IE Product	User Service Definition Operational Capability	Technical Service Level 2	Technical Service Level 1
BI-DIRECTIONAL					
Bde ASAC	UAS Gnd Control Station	Voice (Secure)	Voice	Audio-Based Communication Services	Core Services
Bde ASAC	UAS Gnd Control Station	Instant Message	Instant Messaging	Text-Based Collaboration Services	Core Services
BRIGADE ALL SOURCES ANALYSIS CELL (Bde ASAC) - HUMAN INTELLIGENCE (HUMINT)					
BDE ASAC	HUMINT	ISRR	Requests & Responses	JISR Services	COI Services
BDE ASAC	HUMINT	ISR Sync Matrix	Plans	JISR Services	COI Services
BDE ASAC	HUMINT	PIR	Tasking & Orders	JISR Services	COI Services
BDE ASAC	HUMINT	HPTL	Tasking & Orders	JISR Services	COI Services
BDE ASAC	HUMINT	HVTL	Tasking & Orders	JISR Services	COI Services
HUMINT	BDE ASAC	OS Int	Reports	JISR Services	COI Services
HUMINT	BDE ASAC	Debrief	Reports	JISR Services	COI Services
HUMINT	BDE ASAC	Fingerprint Record	Reports	JISR Services	COI Services
HUMINT	BDE ASAC	TQR	Reports	JISR Services	COI Services
HUMINT	BDE ASAC	HUMINT Info	Reports	JISR Services	COI Services
HUMINT	BDE ASAC	HUMINT Rep	Reports	JISR Services	COI Services
HUMINT	BDE ASAC	HUMINTSUM	Reports	JISR Services	COI Services
HUMINT	BDE ASAC	DNA Data Record	Reports	JISR Services	COI Services
BI-DIRECTIONAL					
BDE ASAC	HUMINT	Voice (Secure)	Voice	Audio-Based Communication Services	Core Services

IER From	IER To	IE Product	User Service Definition Operational Capability	Technical Service Level 2	Technical Service Level 1
BDE ASAC	HUMINT	Instant Message	Instant Messaging	Text-Based Collaboration Services	Core Services
HUMAN INTELLIGENCE (HUMINT) - LOCAL POPULACE					
Local Populace	HUMINT	Open Source Int	Reports	JISR Services	COI Services
BI-DIRECTIONAL					
HUMINT	Local Populace	Voice (Non Secure)	Voice	Audio-Based Communication Services	Core Services
HUMINT	Local Populace	Informal Message	Informal Messaging	Text-Based Collaboration Services	Core Services
HUMINT	Local Populace	Fax	Fax	Fax Services	Core Services
HUMAN INTELLIGENCE (HUMINT) - BATTLE GROUP INTELLIGENCE SUPPORT SECTION (BGISS)					
BI-DIRECTIONAL					
BGISS	HUMINT	Voice (Secure)	Voice	Audio-Based Communication Services	Core Services
HUMAN INTELLIGENCE (HUMINT) - COMPANY INTELLIGENCE SUPPORT TEAM (COIST)					
BI-DIRECTIONAL					
COIST	HUMINT	Voice (Secure)	Voice	Audio-Based Communication Services	Core Services

IER From	IER To	IE Product	User Service Definition Operational Capability	Technical Service Level 2	Technical Service Level 1
COIST	HUMINT	GMTI	VTC	Video Based Collaboration Services	Core Services
BRIGADE ALL SOURCES ANALYSIS CELL (Bde ASAC) - BATTLE GROUP INTELLIGENCE SUPPORT SECTION (BGISS)					
Bde ASAC	BGISS	ISRR	Requests & Responses	JISR Services	COI Services
Bde ASAC	BGISS	ISR Sync Matrix	Plans	JISR Services	COI Services
Bde ASAC	BGISS	PIR	Tasking & Orders	JISR Services	COI Services
Bde ASAC	BGISS	HPTL	Requests & Responses	JISR Services	COI Services
Bde ASAC	BGISS	HVTL	Requests & Responses	JISR Services	COI Services
BGISS	Bde ASAC	Tactical Questioning Report	Reports	JISR Services	COI Services
BGISS	Bde ASAC	Biometric Info	Reports	JISR Services	COI Services
BGISS	Bde ASAC	CRL	Requests & Responses	JISR Services	COI Services
BGISS	Bde ASAC	Imagery	Intel Database Services	JISR Services	COI Services
BGISS	Bde ASAC	FFT Info	Live Tracks	Battlespace Information Services	COI Services
BI-DIRECTIONAL					
Bde ASAC	BGISS	Voice (Secure)	Voice	Audio-Based Communication Services	Core Services
Bde ASAC	BGISS	Instant Message	Instant Messaging	Text-Based Collaboration Services	Core Services
Bde ASAC	BGISS	INTREPS	Reports	JISR Services	COI Services

IER From	IER To	IE Product	User Service Definition Operational Capability	Technical Service Level 2	Technical Service Level 1
BATTLE GROUP INTELLIGENCE SUPPORT SECTION (BGISS) - COMPANY INTELLIGENCE SUPPORT TEAM (COIST)					
BGISS	COIST	CXP	Plans	Joint Services	COI Services
BGISS	COIST	PIR	Tasking & Orders	JISR Services	COI Services
BGISS	COIST	HPTL	Requests & Responses	JISR Services	COI Services
BGISS	COIST	HVTL	Requests & Responses	JISR Services	COI Services
COIST	BGISS	Tactical Questioning Report	Reports	JISR Services	COI Services
COIST	BGISS	Biometric Info	Reports	JISR Services	COI Services
COIST	BGISS	CRL	Requests & Responses	JISR Services	COI Services
COIST	BGISS	FFT Info	Live Tracks	Battlespace Information Services	COI Services
BI-DIRECTIONAL					
BGISS	COIST	Voice (Secure)	Voice	Audio-Based Communication Services	Core Services
BGISS	COIST	Instant Message	Instant Messaging	Text-Based Collaboration Services	Core Services
BGISS	COIST	INTREPS	Reports	JISR Services	COI Services
BATTLE GROUP HEADQUARTERS (BG HQ) - CLOSE OBSERVATION PLATOON (Close Obs Plt)					
BG HQ	Close Obs Plt	IR	Tasking & Orders	JISR Services	COI Services
BG HQ	Close Obs Plt	PIR	Tasking & Orders	JISR Services	COI Services
BG HQ	Close Obs Plt	HPTL	Requests & Responses	JISR Services	COI Services
BG HQ	Close Obs Plt	HVTL	Requests & Responses	JISR Services	COI Services
Close Obs Plt	BG HQ	INTREPS	Reports	JISR Services	COI Services

IER From	IER To	IE Product	User Service Definition Operational Capability	Technical Service Level 2	Technical Service Level 1
Close Obs Plt	BG HQ	FFT Info	Live Tracks	Battlespace Information Services	COI Services
Close Obs Plt	BG HQ	ENSITREP	Operations Assessment Services	Tasking and Order Services	COI Services
Close Obs Plt	BG HQ	OWNSITREP	Operations Assessment Services	Tasking and Order Services	COI Services
Close Obs Plt	BG HQ	Imagery	Intel Database Services	JISR Services	COI Services
BI-DIRECTIONAL					
BG HQ	Close Obs Plt	Voice (Secure)	Voice	Audio-Based Communication Services	Core Services
BG HQ	Close Obs Plt	Instant Message	Instant Messaging	Text-Based Collaboration Services	Core Services
BRIGADE ALL SOURCES ANALYSIS CELL (BDE ASAC) - TECHNICAL INTELLIGENCE EXPLOITATION TEAM (TET)					
Bde ASAC	TET	ISRR	Requests & Responses	JISR Services	COI Services
Bde ASAC	TET	PIR	Tasking & Orders	JISR Services	COI Services
Bde ASAC	TET	HPTL	Requests & Responses	JISR Services	COI Services
Bde ASAC	TET	HVTL	Requests & Responses	JISR Services	COI Services
TET	Bde ASAC	TECHINT	Intel Database Services	JISR Services	COI Services
BI-DIRECTIONAL					
Bde ASAC	TET	Voice (Secure)	Voice	Audio-Based Communication Services	Core Services

IER From	IER To	IE Product	User Service Definition Operational Capability	Technical Service Level 2	Technical Service Level 1
Bde ASAC	TET	Instant Message	Instant Messaging	Text-Based Collaboration Services	Core Services
COMPANY INTELLIGENCE SUPPORT TEAM (COIST) - TECHNICAL INTELLIGENCE EXPLOITATION TEAM (TET)					
BI-DIRECTIONAL					
Bde ASAC	TET	Voice (Secure)	Voice	Audio-Based Communication Services	Core Services
Bde ASAC	TET	Instant Message	Instant Messaging	Text-Based Collaboration Services	Core Services
COY HQ - Recce Patrols					
Coy HQ	Recce Patrols	IR	Tasking & Orders	JISR Services	COI Services
Coy HQ	Recce Patrols	PIR	Tasking & Orders	JISR Services	COI Services
Coy HQ	Recce Patrols	HPTL	Requests & Responses	JISR Services	COI Services
Coy HQ	Recce Patrols	HVTL	Requests & Responses	JISR Services	COI Services
Recce Patrols	Coy HQ	INTREPS	Reports	JISR Services	COI Services
Recce Patrols	Coy HQ	FFT Info	Live Tracks	Battlespace Information Services	COI Services
Recce Patrols	Coy HQ	ENSITREP	Operations Assessment Services	Tasking and Order Services	COI Services

NATO UNCLASSIFIED
DRAFT

ANNEX C TO
 Draft MC 0640

IER From	IER To	IE Product	User Service Definition Operational Capability	Technical Service Level 2	Technical Service Level 1
Recce Patrols	Coy HQ	OWNSITREP	Operations Assessment Services	Tasking and Order Services	COI Services
BI-DIRECTIONAL					
Coy HQ	Recce Patrols	Voice (Secure)	Voice	Audio-Based Communication Services	Core Services
Coy HQ	Recce Patrols	Instant Message	Instant Messaging	Text-Based Collaboration Services	Core Services

Table C-2: Land Intelligence in a VJTF(L) Scenario Product Dissemination and Consumption

MJO+ INTELLIGENCE IER

12. Specific H2H and systems information product exchanges to enable the effective collection, exploitation, dissemination and receipt of intelligence product in the land environment during a MJO+ scenario are depicted in Figure C-4. The unidirectional red and green arrows represent products either consumed or disseminated from intelligence entities within the land environment. The bi-directional black arrows represent products that are both disseminated and consumed by land based intelligence entities.

NATO UNCLASSIFIED
DRAFT

ANNEX C TO
 MC 0640

13. As introduced in Figure C-4, the products depicted in the table C-3 details the unidirectional and bi-directional products relating to the intelligence process within a land environment under a MJO+ scenario. The column 'IER From' and 'IER To' details the C2 entities which the information products are exchanged with, the third column lists the product that is exchanged. Column 4 lists the operational capability that the product supports and columns 5 - 6 map the product to the service type as detailed in the C3 Taxonomy nomenclature:

IER From	IER To	IE Product	User Service Definition Operational Capability	Technical Service Level 2	Technical Service Level 1
JTF HQ - LAND INTELLIGENCE FUSION CELL					
JTF HQ	LANDCOM	OPLAN Annex D	Plans	Joint Services	COI Services
JTF HQ	LANDCOM	CTL	Tasking & Orders	JISR Services	COI Services
LANDCOM	JTF HQ	FMV	Full Motion Video	JISR Services	COI Services
BI-DIRECTIONAL					
JTF HQ	LANDCOM	Voice (Secure)	Voice	Audio-Based Communication Services	Core Services
JTF HQ	LANDCOM	Formal Message	Formal Messaging	Military Messaging Service	Core Enterprise Services
JTF HQ	LANDCOM	Informal Message	Informal Messaging	Informal Messaging Services	Core Services
JTF HQ	LANDCOM	Instant Message	Instant Messaging	Text-Based Collaboration Services	Core Services
JTF HQ	LANDCOM	Office Collaboration (Audio)	Collaboration	Audio-Based Communication Services	Core Enterprise Services
JTF HQ	LANDCOM	Office Collaboration (AV)	Collaboration	Video-Based Communication Services	Core Enterprise Services

IER From	IER To	IE Product	User Service Definition Operational Capability	Technical Service Level 2	Technical Service Level 1
JTF HQ	LANDCOM	Office Collaboration (Chat)	Collaboration	Text-Based Collaboration Services	Core Enterprise Services
JTF HQ	LANDCOM	VTC	VTC	Video Based Collaboration Services	Core Services
JTF HQ	LANDCOM	GMTI	Situational Awareness	JISR Services	COI Services
JTF HQ	LANDCOM	PIR	Tasking & Orders	JISR Services	COI Services
JTF HQ	LANDCOM	ISR Priority Bands	Tasking & Orders	JISR Services	COI Services
JTF HQ	LANDCOM	INTREPS	Reports	JISR Services	COI Services
JTF HQ	LANDCOM	National Requests & Responses	Requests & Responses	JISR Services	COI Services
JTF HQ	LANDCOM	Imagery	Intel Database Services	JISR Services	COI Services
JTF HQ	LANDCOM	Motion Imagery	Intel Database Services	JISR Services	COI Services
JTF HQ	LANDCOM	ISRR	Requests & Responses	JISR Services	COI Services
JTF HQ	LANDCOM	RFI	Requests & Responses	JISR Services	COI Services
JTF HQ	LANDCOM	CRL	Requests & Responses	JISR Services	COI Services
JTF HQ	LANDCOM	ICP	Plans	JISR Services	COI Services
JTF HQ	LANDCOM	ISR Sync Matrix	Plans	JISR Services	COI Services
LANDCOM - SPECIAL OPERATIONS COMPONENT COMMAND					
SOCC	LANDCOM	Biometric Info	Reports	JISR Services	COI Services
BI-DIRECTIONAL					
LANDCOM	SOCC	Voice (Secure)	Voice	Audio-Based Communication Services	Core Services
LANDCOM	SOCC	Formal Message	Formal Messaging	Military Messaging Service	Core Enterprise Services

IER From	IER To	IE Product	User Service Definition Operational Capability	Technical Service Level 2	Technical Service Level 1
LANDCOM	SOCC	Informal Message	Informal Messaging	Informal Messaging Services	Core Services
LANDCOM	SOCC	Instant Message	Instant Messaging	Text-Based Collaboration Services	Core Services
LANDCOM	SOCC	VTC	VTC	Video Based Collaboration Services	Core Services
LANDCOM	SOCC	INTREPS	Reports	JISR Services	COI Services
LANDCOM	SOCC	National Requests & Responses	Requests & Responses	JISR Services	COI Services
LANDCOM	SOCC	FMV	Full Motion Video	JISR Services	COI Services
LANDCOM	SOCC	Imagery	Intel Database Services	JISR Services	COI Services
LANDCOM	SOCC	Motion Imagery	Intel Database Services	JISR Services	COI Services
LANDCOM	SOCC	RFI	Requests & Responses	JISR Services	COI Services
LAND INTELLIGENCE FUSION CELL - CORPS INTELLIGENCE FUSION CELL					
LIFC	CIFC	INTREPS	Reports	JISR Services	COI Services
LIFC	CIFC	RIP	Situational Awareness	JISR Services	COI Services
LIFC	CIFC	JIPB Product	Plans	JISR Services	COI Services
LIFC	CIFC	METOC Info	METEO	Environmental Services	COI Services
LIFC	CIFC	Imagery	Intel Database Services	JISR Services	COI Services
LIFC	CIFC	Biometric Info	Reports	JISR Services	COI Services
LIFC	CIFC	Collection & Exploitation Plan (CXP)	Plans	Joint Services	COI Services
LIFC	CIFC	OPLAN Annex D	Operation Order Services	Tasking and Order Services	COI Services

NATO UNCLASSIFIED
DRAFT

ANNEX C TO
 MC 0640

IER From	IER To	IE Product	User Service Definition Operational Capability	Technical Service Level 2	Technical Service Level 1
LIFC	CIFC	PIR	Tasking & Orders	JISR Services	COI Services
LIFC	CIFC	ISR Priority Bands	Tasking & Orders	JISR Services	COI Services
LIFC	CIFC	CTL	Tasking & Orders	JISR Services	COI Services
LIFC	CIFC	ICP	Plans	JISR Services	COI Services
CIFC	LIFC	RIP	Situational Awareness	JISR Services	COI Services
CIFC	LIFC	EW Info	Reports	JISR Services	COI Services
CIFC	LIFC	CRL	Requests & Responses	JISR Services	COI Services
BI-DIRECTIONAL					
LIFC	CIFC	Voice (Secure)	Voice	Audio-Based Communication Services	Core Services
LIFC	CIFC	Formal Message	Formal Messaging	Military Messaging Service	Core Enterprise Services
LIFC	CIFC	Informal Message	Informal Messaging	Informal Messaging Services	Core Services
LIFC	CIFC	Instant Message	Instant Messaging	Text-Based Collaboration Services	Core Services
LIFC	CIFC	Office Collaboration (Audio)	Collaboration	Audio-Based Communication Services	Core Enterprise Services
LIFC	CIFC	Office Collaboration (AV)	Collaboration	Video-Based Communication Services	Core Enterprise Services
LIFC	CIFC	Office Collaboration (Chat)	Collaboration	Text-Based Collaboration Services	Core Enterprise Services

IER From	IER To	IE Product	User Service Definition Operational Capability	Technical Service Level 2	Technical Service Level 1
LIFC	CIFC	VTC	VTC	Video Based Collaboration Services	Core Services
LIFC	CIFC	Document Collaboration & Storage	Information Mgt	Content Management Services	Core Enterprise Services
LIFC	CIFC	GMTI	Situational Awareness	JISR Services	Core Enterprise Services
LIFC	CIFC	INTREPS	Reports	JISR Services	COI Services
LIFC	CIFC	Motion Imagery	Intel Database Services	JISR Services	COI Services
LIFC	CIFC	Biometric Info	Reports	JISR Services	COI Services
LIFC	CIFC	ISRR	Requests & Responses	JISR Services	COI Services
LIFC	CIFC	RFI	Requests & Responses	JISR Services	COI Services
LIFC	CIFC	ISR Sync Matrix	Plans	JISR Services	COI Services
LAND INTELLIGENCE FUSION CELL - ISTAR ASSETS					
LIFC	ISTAR ASSETS	ISTAR Asset Report	Reports	JISR Services	COI Services
BI-DIRECTIONAL					
LIFC	ISTAR ASSETS	Voice (Secure)	Informal Messaging	Informal Messaging Services	Core Services
LIFC	ISTAR ASSETS	Informal Message	Instant Messaging	Text-Based Collaboration Services	Core Services
LIFC	ISTAR ASSETS	Instant Message	Instant Messaging	Text-Based Collaboration Services	Core Services
CORPS INTELLIGENCE FUSION CENTRE - DIVISION ALL SOURCES ANALYSIS CELL					
CIFC	Div ASAC	RIP	Situational Awareness	JISR Services	COI Services
CIFC	Div ASAC	JIPB Product	Plans	JISR Services	COI Services

NATO UNCLASSIFIED
DRAFT

ANNEX C TO
 MC 0640

IER From	IER To	IE Product	User Service Definition Operational Capability	Technical Service Level 2	Technical Service Level 1
CIFC	Div ASAC	METOC Info	METEO	Environmental Services	COI Services
CIFC	Div ASAC	Imagery	Intel Database Services	JISR Services	COI Services
CIFC	Div ASAC	Biometric Info	Reports	JISR Services	COI Services
CIFC	Div ASAC	Collection & Exploitation Plan (CXP)	Plans	Joint Services	COI Services
CIFC	Div ASAC	PIR	Tasking & Orders	JISR Services	COI Services
CIFC	Div ASAC	ISR Priority Bands	Tasking & Orders	JISR Services	COI Services
CIFC	Div ASAC	CTL	Tasking & Orders	JISR Services	COI Services
CIFC	Div ASAC	ICP	Plans	JISR Services	COI Services
Div ASAC	CIFC	CRL	Requests & Responses	JISR Services	COI Services
BI-DIRECTIONAL					
CIFC	Div ASAC	Voice (Secure)	Voice	Audio-Based Communication Services	Core Services
CIFC	Div ASAC	Formal Message	Formal Messaging	Military Messaging Service	Core Enterprise Services
CIFC	Div ASAC	Informal Message	Informal Messaging	Informal Messaging Services	Core Services
CIFC	Div ASAC	Instant Message	Instant Messaging	Text-Based Collaboration Services	Core Services
CIFC	Div ASAC	Office Collaboration (Audio)	Collaboration	Audio-Based Communication Services	Core Enterprise Services

IER From	IER To	IE Product	User Service Definition Operational Capability	Technical Service Level 2	Technical Service Level 1
CIFC	Div ASAC	Office Collaboration (AV)	Collaboration	Video-Based Communication Services	Core Enterprise Services
CIFC	Div ASAC	Office Collaboration (Chat)	Collaboration	Text-Based Collaboration Services	Core Enterprise Services
CIFC	Div ASAC	Document Collaboration & Storage	Information Mgt	Content Management Services	Core Enterprise Services
CIFC	Div ASAC	VTC	VTC	Video Based Collaboration Services	Core Services
CIFC	Div ASAC	GMTI	Situational Awareness	JISR Services	Core Enterprise Services
CIFC	Div ASAC	INTREPS	Reports	JISR Services	COI Services
CIFC	Div ASAC	Motion Imagery	Intel Database Services	JISR Services	COI Services
CIFC	Div ASAC	Biometric Info	Reports	JISR Services	COI Services
CIFC	Div ASAC	ISRR	Requests & Responses	JISR Services	COI Services
CIFC	Div ASAC	RFI	Requests & Responses	JISR Services	COI Services
CIFC	Div ASAC	ISR Sync Matrix	Plans	JISR Services	COI Services
CORPS INTELLIGENCE FUSION CENTRE - NATIONAL INTELLIGENCE CELL (NIC)					
BI-DIRECTIONAL					
CIFC	NIC	Voice (Secure)	Voice	Audio-Based Communication Services	Core Services
CIFC	NIC	Formal Message	Formal Messaging	Military Messaging Service	Core Enterprise Services

IER From	IER To	IE Product	User Service Definition Operational Capability	Technical Service Level 2	Technical Service Level 1
CIFC	NIC	Informal Message	Informal Messaging	Informal Messaging Services	Core Services
CIFC	NIC	National Requests & Responses	Requests & Responses	JISR Services	COI Services
CORPS INTELLIGENCE FUSION CENTRE - ISTAR ASSETS (IA)					
CIFC	IA	METOC Info	METEO	Environmental Services	COI Services
CIFC	IA	ISR Sync Matrix	Plans	JISR Services	COI Services
CIFC	IA	ISRR	Requests & Responses	JISR Services	COI Services
CIFC	IA	PIR	Tasking & Orders	JISR Services	COI Services
CIA	CIFC	MIEXREP	Reports	JISR Services	COI Services
CIA	CIFC	FMV	JISR Imagery and Video Services	JISR Services	COI Services
CIA	CIFC	INTREPS	Reports	JISR Services	COI Services
CIA	CIFC	Motion Imagery	Intel Database Services	JISR Services	COI Services
BI-DIRECTIONAL					
CIFC	IA	Voice (Secure)	Voice	Audio-Based Communication Services	Core Services
CIFC	IA	Informal Message	Informal Messaging	Informal Messaging Services	Core Services
CIFC	IA	Instant Message	Instant Messaging	Text-Based Collaboration Services	Core Services
CIFC	IA	Office Collaboration (Audio)	Collaboration	Audio-Based Communication Services	Core Enterprise Services

IER From	IER To	IE Product	User Service Definition Operational Capability	Technical Service Level 2	Technical Service Level 1
CIFC	IA	Office Collaboration (Chat)	Collaboration	Text-Based Collaboration Services	Core Enterprise Services
CIFC	IA	Document Collaboration & Storage	Information Mgt	Content Management Services	Core Enterprise Services
CORPS INTELLIGENCE FUSION CENTRE (CIFC) - ELECTRONIC WARFARE COORDINATION CELL (EWCC)					
CIFC	EWCC	CCIR	Tasking & Orders	JISR Services	COI Services
CIFC	EWCC	PIR	Tasking & Orders	JISR Services	COI Services
CIFC	EWCC	HPTL	Requests & Responses	JISR Services	COI Services
CIFC	EWCC	HVTL	Requests & Responses	JISR Services	COI Services
EWCC	CIFC	EW Info	Reports	JISR Services	COI Services
BI-DIRECTIONAL					
CIFC	EWCC	Voice (Secure)	Voice	Audio-Based Communication Services	Core Services
CIFC	EWCC	Informal Message	Informal Messaging	Informal Messaging Services	Core Services
CIFC	EWCC	Instant Message	Instant Messaging	Text-Based Collaboration Services	Core Services
CIFC	EWCC	Office Collaboration (Audio)	Collaboration	Audio-Based Communication Services	Core Enterprise Services
CIFC	EWCC	Office Collaboration (Chat)	Collaboration	Text-Based Collaboration Services	Core Enterprise Services

NATO UNCLASSIFIED
DRAFT

ANNEX C TO
MC 0640

IER From	IER To	IE Product	User Service Definition Operational Capability	Technical Service Level 2	Technical Service Level 1
CIFC	EWCC	Document Collaboration & Storage	Information Mgt	Content Management Services	Core Enterprise Services
DIVISION ALL SOURCES ANALYSIS CELL (DIV ASAC)- BRIGADE ALL SOURCES ANALYSIS CELL (BDE ASAC)					
Div ASAC	Bde ASAC	RIP	Situational Awareness	JISR Services	COI Services
Div ASAC	Bde ASAC	JIPB Product	Plans	JISR Services	COI Services
Div ASAC	Bde ASAC	METOC Info	METEO	Environmental Services	COI Services
Div ASAC	Bde ASAC	Imagery	Intel Database Services	JISR Services	COI Services
Div ASAC	Bde ASAC	Biometric Info	Reports	JISR Services	COI Services
Div ASAC	Bde ASAC	CXP	Plans	Joint Services	COI Services
Div ASAC	Bde ASAC	PIR	Tasking & Orders	JISR Services	COI Services
Div ASAC	Bde ASAC	ISR Priority Bands	Tasking & Orders	JISR Services	COI Services
Div ASAC	Bde ASAC	CTL	Tasking & Orders	JISR Services	COI Services
Div ASAC	Bde ASAC	ICP	Plans	JISR Services	COI Services
Div ASAC	Bde ASAC	CRL	Requests & Responses	JISR Services	COI Services
BI-DIRECTIONAL					
Div ASAC	Bde ASAC	Voice (Secure)	Voice	Audio-Based Communication Services	Core Services
Div ASAC	Bde ASAC	Formal Message	Formal Messaging	Military Messaging Service	Core Enterprise Services
Div ASAC	Bde ASAC	Informal Message	Informal Messaging	Informal Messaging Services	Core Services
Div ASAC	Bde ASAC	Instant Message	Instant Messaging	Text-Based Collaboration Services	Core Services

NATO UNCLASSIFIED
DRAFT

ANNEX C TO
MC 0640

IER From	IER To	IE Product	User Service Definition Operational Capability	Technical Service Level 2	Technical Service Level 1
Div ASAC	Bde ASAC	Office Collaboration (Audio)	Collaboration	Audio-Based Communication Services	Core Enterprise Services
Div ASAC	Bde ASAC	Office Collaboration (AV)	Collaboration	Video-Based Communication Services	Core Enterprise Services
Div ASAC	Bde ASAC	Office Collaboration (Chat)	Collaboration	Text-Based Collaboration Services	Core Enterprise Services
Div ASAC	Bde ASAC	Document Collaboration & Storage	Information Mgt	Content Management Services	Core Enterprise Services
Div ASAC	Bde ASAC	VTC	VTC	Video Based Collaboration Services	Core Services
Div ASAC	Bde ASAC	GMTI	Situational Awareness	JISR Services	Core Enterprise Services
Div ASAC	Bde ASAC	INTREPS	Reports	JISR Services	COI Services
Div ASAC	Bde ASAC	Motion Imagery	Plans	JISR Services	COI Services
Div ASAC	Bde ASAC	Biometric Info	Reports	JISR Services	COI Services
Div ASAC	Bde ASAC	ISRR	Requests & Responses	JISR Services	COI Services
Div ASAC	Bde ASAC	RFI	Requests & Responses	JISR Services	COI Services
Div ASAC	Bde ASAC	ISR Sync Matrix	Plans	JISR Services	COI Services
BRIGADE ALL SOURCES ANALYSIS CELL (BDE ASAC) - ELECTRONIC WARFARE COORDINATION CENTRE (EWCC)					
BDE ASAC	EWCC	CCIR	Tasking & Orders	JISR Services	COI Services
BDE ASAC	EWCC	PIR	Tasking & Orders	JISR Services	COI Services
BDE ASAC	EWCC	HPTL	Requests & Responses	JISR Services	COI Services
BDE ASAC	EWCC	HVTL	Requests & Responses	JISR Services	COI Services

NATO UNCLASSIFIED
DRAFT

ANNEX C TO
 MC 0640

IER From	IER To	IE Product	User Service Definition Operational Capability	Technical Service Level 2	Technical Service Level 1
EWCC	Bde ASAC	EW Info	Reports	EW Services	COI Services
BI-DIRECTIONAL					
BDE ASAC	EWCC	Voice (Secure)	Voice	Audio-Based Communication Services	Core Services
BDE ASAC	EWCC	Instant Message	Instant Messaging	Text-Based Collaboration Services	COI Services
ELECTRONIC WARFARE COORDINATION CENTRE (EWCC) - ELECTRONIC WARFARE ASSETS (EW ASSETS)					
EWCC	EW ASSETS	OPTASK EW	Tasking & Orders	EW Services	COI Services
EW ASSETS	EWCC	EW SITREP	Reports	EW Services	COI Services
EW ASSETS	EWCC	RFL	Reports	EW Services	COI Services
BI-DIRECTIONAL					
EWCC	EW ASSETS	Voice (Secure)	Voice	Audio-Based Communication Services	Core Services
EWCC	EW ASSETS	Instant Message	Instant Messaging	Text-Based Collaboration Services	Core Services
EW ASSETS	EWCC	EW Info	Reports	EW Services	COI Services
BRIGADE ALL SOURCES ANALYSIS CELL (BDE ASAC) - BRIGADE RECONNAISSANCE FORCE (BDE Recce Force)					
Bde ASAC	Bde Recce Force	IR	Tasking & Orders	JISR Services	COI Services
Bde ASAC	Bde Recce Force	METOC Info	Reports	JISR Services	COI Services

NATO UNCLASSIFIED
DRAFT

ANNEX C TO
MC 0640

IER From	IER To	IE Product	User Service Definition Operational Capability	Technical Service Level 2	Technical Service Level 1
Bde ASAC	Bde Recce Force	PIR	Tasking & Orders	JISR Services	COI Services
Bde ASAC	Bde Recce Force	HPTL	Requests & Responses	JISR Services	COI Services
Bde ASAC	Bde Recce Force	HVTL	Requests & Responses	JISR Services	COI Services
Bde Recce Force	Bde ASAC	ENSITREP	Operations Assessment Services	Tasking and Order Services	COI Services
Bde Recce Force	Bde ASAC	OWNSITREP	Operations Assessment Services	Tasking and Order Services	COI Services
Bde Recce Force	Bde ASAC	FFT Info	Track Services	Battlespace Information Services	COI Services
Bde Recce Force	Bde ASAC	INTREPS	Reports	JISR Services	COI Services
BI-DIRECTIONAL					
Bde ASAC	Bde Recce Force	Voice (Secure)	Voice	Audio-Based Communication Services	Core Services
Bde ASAC	Bde Recce Force	Instant Message	Instant Messaging	Text-Based Collaboration Services	Core Services
BRIGADE ALL SOURCES ANALYSIS CELL (BDE ASAC) - FIRE SUPPORT COORDINATION CELL (FSCC)					
Bde ASAC	FSCC	ISR Sync Matrix	Plans	JISR Services	COI Services
Bde ASAC	FSCC	ISRR	Requests & Responses	JISR Services	COI Services
FSCC	Bde ASAC	Imagery	Intel Database Services	JISR Services	COI Services

NATO UNCLASSIFIED
DRAFT

ANNEX C TO
 MC 0640

IER From	IER To	IE Product	User Service Definition Operational Capability	Technical Service Level 2	Technical Service Level 1
BI-DIRECTIONAL					
Bde ASAC	FSCC	Voice (Secure)	Voice	Audio-Based Communication Services	Core Services
Bde ASAC	FSCC	Instant Message	Instant Messaging	Text-Based Collaboration Services	Core Services
BRIGADE ALL SOURCES ANALYSIS CELL (BDE ASAC) - UNMANND AERIAL SURVEILLANCE (UAS Gnd Control Stn)					
Bde ASAC	UAS Gnd Control Station	METOC Info	Reports	JISR Services	COI Services
Bde ASAC	UAS Gnd Control Station	ISR Sync Matrix	Plans	JISR Services	COI Services
Bde ASAC	UAS Gnd Control Station	ISRR	Requests & Responses	JISR Services	COI Services
Bde ASAC	UAS Gnd Control Station	PIR	Tasking & Orders	JISR Services	COI Services
UAS Gnd Control Station	Bde ASAC	MIEXREP	Reports	JISR Services	COI Services
UAS Gnd Control Station	Bde ASAC	FMV	Full Motion Video	JISR Services	COI Services

NATO UNCLASSIFIED
DRAFT

ANNEX C TO
MC 0640

IER From	IER To	IE Product	User Service Definition Operational Capability	Technical Service Level 2	Technical Service Level 1
UAS Gnd Control Station	Bde ASAC	INTREPS	Reports	JISR Services	COI Services
BI-DIRECTIONAL					
Bde ASAC	UAS Gnd Control Station	Voice (Secure)	Voice	Audio-Based Communication Services	Core Services
Bde ASAC	UAS Gnd Control Station	Instant Message	Instant Messaging	Text-Based Collaboration Services	Core Services
BRIGADE ALL SOURCES ANALYSIS CELL (BDE ASAC) - HUMAN INTELLIGENCE (HUMINT)					
BDE ASAC	HUMINT	ISRR	Requests & Responses	JISR Services	COI Services
BDE ASAC	HUMINT	ISR Sync Matrix	Plans	JISR Services	COI Services
BDE ASAC	HUMINT	PIR	Tasking & Orders	JISR Services	COI Services
BDE ASAC	HUMINT	HPTL	Tasking & Orders	JISR Services	COI Services
BDE ASAC	HUMINT	HVTL	Tasking & Orders	JISR Services	COI Services
HUMINT	BDE ASAC	OS Int	Reports	JISR Services	COI Services
HUMINT	BDE ASAC	Debrief	Reports	JISR Services	COI Services
HUMINT	BDE ASAC	Fingerprint Record	Reports	JISR Services	COI Services
HUMINT	BDE ASAC	TQR	Reports	JISR Services	COI Services
HUMINT	BDE ASAC	HUMINT Info	Reports	JISR Services	COI Services
HUMINT	BDE ASAC	HUMINT Rep	Reports	JISR Services	COI Services
HUMINT	BDE ASAC	HUMINTSUM	Reports	JISR Services	COI Services
HUMINT	BDE ASAC	DNA Data Record	Reports	JISR Services	COI Services

NATO UNCLASSIFIED
DRAFT

ANNEX C TO
 MC 0640

IER From	IER To	IE Product	User Service Definition Operational Capability	Technical Service Level 2	Technical Service Level 1
BI-DIRECTIONAL					
BDE ASAC	HUMINT	Voice (Secure)	Voice	Audio-Based Communication Services	Core Services
BDE ASAC	HUMINT	Instant Message	Instant Messaging	Text-Based Collaboration Services	Core Services
HUMAN INTELLIGENCE (HUMINT) - LOCAL POPULACE					
Local Populace	HUMINT	Open Source Int	Reports	JISR Services	COI Services
BI-DIRECTIONAL					
HUMINT	Local Populace	Voice (Non Secure)	Voice	Audio-Based Communication Services	Core Services
HUMINT	Local Populace	Informal Message	Informal Messaging	Text-Based Collaboration Services	Core Services
HUMINT	Local Populace	Fax	Fax	Fax Services	Core Services
HUMAN INTELLIGENCE (HUMINT) - BATTLE GROUP INTELLIGENCE SUPPORT SECTION (BGISS)					
BI-DIRECTIONAL					
BGISS	HUMINT	Voice (Secure)	Voice	Audio-Based Communication Services	Core Services

IER From	IER To	IE Product	User Service Definition Operational Capability	Technical Service Level 2	Technical Service Level 1
HUMAN INTELLIGENCE (HUMINT) - COMPANY INTELLIGENCE SUPPORT TEAM (COIST)					
BI-DIRECTIONAL					
COIST	HUMINT	Voice (Secure)	Voice	Audio-Based Communication Services	Core Services
BRIGADE ALL SOURCES ANALYSIS CELL (BDE ASAC) - BATTLE GROUP INTELLIGENCE SUPPORT SECTION (BGISS)					
Bde ASAC	BGISS	ISRR	Requests & Responses	JISR Services	COI Services
Bde ASAC	BGISS	ISR Sync Matrix	Plans	JISR Services	COI Services
Bde ASAC	BGISS	PIR	Tasking & Orders	JISR Services	COI Services
Bde ASAC	BGISS	HPTL	Requests & Responses	JISR Services	COI Services
Bde ASAC	BGISS	HVTL	Requests & Responses	JISR Services	COI Services
BGISS	Bde ASAC	Tactical Questioning Report	Reports	JISR Services	COI Services
BGISS	Bde ASAC	Biometric Info	Reports	JISR Services	COI Services
BGISS	Bde ASAC	CRL	Requests & Responses	JISR Services	COI Services
BGISS	Bde ASAC	Imagery	Intel Database Services	JISR Services	COI Services
BI-DIRECTIONAL					
Bde ASAC	BGISS	Voice (Secure)	Voice	Audio-Based Communication Services	Core Services
Bde ASAC	BGISS	Instant Message	Instant Messaging	Text-Based Collaboration Services	Core Services
Bde ASAC	BGISS	INTREPS	Reports	JISR Services	COI Services
BATTLE GROUP INTELLIGENCE SUPPORT SECTION (BGISS) - COMPANY INTELLIGENCE SUPPORT TEAM (COIST)					
BGISS	COIST	CXP	Plans	Joint Services	COI Services

IER From	IER To	IE Product	User Service Definition Operational Capability	Technical Service Level 2	Technical Service Level 1
BGISS	COIST	PIR	Tasking & Orders	JISR Services	COI Services
BGISS	COIST	HPTL	Requests & Responses	JISR Services	COI Services
BGISS	COIST	HVTL	Requests & Responses	JISR Services	COI Services
COIST	BGISS	Tactical Questioning Report	Reports	JISR Services	COI Services
COIST	BGISS	Biometric Info	Reports	JISR Services	COI Services
COIST	BGISS	CRL	Requests & Responses	JISR Services	COI Services
BI-DIRECTIONAL					
BGISS	COIST	Voice (Secure)	Voice	Audio-Based Communication Services	Core Services
BGISS	COIST	Instant Message	Instant Messaging	Text-Based Collaboration Services	Core Services
BGISS	COIST	INTREPS	Reports	JISR Services	COI Services
BATTLE GROUP (BG HQ) - CLOSE OBSERVATION PLATOON (Close Obs Plt)					
BG HQ	Close Obs Plt	IR	Tasking & Orders	JISR Services	COI Services
BG HQ	Close Obs Plt	PIR	Tasking & Orders	JISR Services	COI Services
BG HQ	Close Obs Plt	HPTL	Requests & Responses	JISR Services	COI Services
BG HQ	Close Obs Plt	HVTL	Requests & Responses	JISR Services	COI Services
Close Obs Plt	BG HQ	INTREPS	Reports	JISR Services	COI Services

IER From	IER To	IE Product	User Service Definition Operational Capability	Technical Service Level 2	Technical Service Level 1
Close Obs Plt	BG HQ	FFT Info	Intel Database Services	JISR Services	COI Services
Close Obs Plt	BG HQ	ENSITREP	Operations Assessment Services	Tasking and Order Services	COI Services
Close Obs Plt	BG HQ	OWNSITREP	Operations Assessment Services	Tasking and Order Services	COI Services
Close Obs Plt	BG HQ	Imagery	Intel Database Services	JISR Services	COI Services
BI-DIRECTIONAL					
BG HQ	Close Obs Plt	Voice (Secure)	Voice	Audio-Based Communication Services	Core Services
BG HQ	Close Obs Plt	Instant Message	Instant Messaging	Text-Based Collaboration Services	Core Services
BRIGADE ALL SOURCES ANALYSIS CELL (BDE ASAC) - TECHNICAL INTELLIGENCE EXPLOITATION TEAM (TET)					
Bde ASAC	TET	ISRR	Requests & Responses	JISR Services	COI Services
Bde ASAC	TET	PIR	Tasking & Orders	JISR Services	COI Services
Bde ASAC	TET	HPTL	Requests & Responses	JISR Services	COI Services
Bde ASAC	TET	HVTL	Requests & Responses	JISR Services	COI Services
TET	Bde ASAC	TECHINT	Intel Database Services	JISR Services	COI Services
BI-DIRECTIONAL					
Bde ASAC	TET	Voice (Secure)	Voice	Audio-Based Communication Services	Core Services
Bde ASAC	TET	Instant Message	Instant Messaging	Text-Based Collaboration Services	Core Services

IER From	IER To	IE Product	User Service Definition Operational Capability	Technical Service Level 2	Technical Service Level 1
COMPANY INTELLIGENCE SUPPORT TEAM (COIST) - TECHNICAL INTELLIGENCE EXPLOITATION TEAM (TET)					
BI-DIRECTIONAL					
Bde ASAC	TET	Voice (Secure)	Voice	Audio-Based Communication Services	Core Services
Bde ASAC	TET	Instant Message	Instant Messaging	Text-Based Collaboration Services	Core Services
COMPANY HEADQUARTERS (COY HQ) - RECONNAISSANCE PATROLS (Recce Patrols)					
Coy HQ	Recce Patrols	IR	Tasking & Orders	JISR Services	COI Services
Coy HQ	Recce Patrols	PIR	Tasking & Orders	JISR Services	COI Services
Coy HQ	Recce Patrols	HPTL	Requests & Responses	JISR Services	COI Services
Coy HQ	Recce Patrols	HVTL	Requests & Responses	JISR Services	COI Services
Recce Patrols	Coy HQ	INTREPS	Reports	JISR Services	COI Services
Recce Patrols	Coy HQ	FFT Info	Intel Database Services	JISR Services	COI Services
Recce Patrols	Coy HQ	ENSITREP	Operations Assessment Services	Tasking and Order Services	COI Services
Recce Patrols	Coy HQ	OWNSITREP	Operations Assessment Services	Tasking and Order Services	COI Services

IER From	IER To	IE Product	User Service Definition Operational Capability	Technical Service Level 2	Technical Service Level 1
BI-DIRECTIONAL					
Coy HQ	Recce Patrols	Voice (Secure)	Voice	Audio-Based Communication Services	Core Services
Coy HQ	Recce Patrols	Instant Message	Instant Messaging	Text-Based Collaboration Services	Core Services

Table C-3: Land Intelligence in a MJO+ Scenario Product Dissemination and Consumption

VJTF(L) FIRE SUPPORT IER

14. Specific C2 and H2H information product exchange to enable the effective Fire Support to be provided in the land environment during a VJTF(L) scenario is depicted in Figure C-5. The unidirectional red and green arrows represent products either consumed or disseminated from Fire Support entities within the land environment. The bi-directional black arrows represent products that are both disseminated and consumed by Fire Support entities in support of a Land based deployment.

15. As introduced in Figure C-5, the products depicted in the Table C-4 details the unidirectional and bi-directional products relating to the Fire Support process within a land environment under a VJTF(L) scenario. The column 'IER From' and 'IER To' details the C2 entities which the information products are exchanged with, the third column lists the product that is exchanged. Column 4 lists the operational capability that the product supports and columns 5 - 6 map the product to the service type as detailed in the C3 Taxonomy nomenclature:

IER From	IER To	IE Product	User Service Definition Operational Capability	Technical Service Level 2	Technical Service Level 1
JOINT FORCE TARGET SUPPORT CELL (JFTSC) - CORPS TARGET SUPPORT CELL (TSC)					
JFC JFTSC	CTSC	JPTL	Targeting Services	Operations Planning Services	COI Services
JFC JFTSC	CTSC	TEAS	Targeting Services	Operations Planning Services	COI Services
JFC JFTSC	CTSC	NSL	Targeting Services	Operations Planning Services	COI Services
JFC JFTSC	CTSC	RTL	Targeting Services	Operations Planning Services	COI Services
CTSC	JFC JFTSC	TNL	Targeting Services	Operations Planning Services	COI Services
CTSC	JFC JFTSC	Status Reports	Reports	Joint Services	COI Services
CTSC	JFC JFTSC	BDA	Reports	Tasking & Order Services	COI Services

NATO UNCLASSIFIED
DRAFT

ANNEX C TO
 MC 0640

IER From	IER To	IE Product	User Service Definition Operational Capability	Technical Service Level 2	Technical Service Level 1
BI-DIRECTIONAL					
JFC JFTSC	CTSC	Voice (Secure)	Voice	Audio-Based Communication Services	Core Services
JFC JFTSC	CTSC	Formal Message	Formal Messaging	Military Messaging Service	Core Services
JFC JFTSC	CTSC	Informal Message	Informal Messaging	Informal Messaging Services	Core Services
JFC JFTSC	CTSC	Instant Message	Instant Messaging	Text-Based Collaboration Services	Core Services
JFC JFTSC	CTSC	Office Collaboration (Audio)	Collaboration	Audio-Based Communication Services	Core Services
JFC JFTSC	CTSC	Office Collaboration (AV)	Collaboration	Video-Based Communication Services	Core Services
JFC JFTSC	CTSC	Office Collaboration (Chat)	Collaboration	Text-Based Collaboration Services	Core Services
JFC JFTSC	CTSC	VTC	VTC	Video Based Collaboration Services	Core Services
JFC JFTSC	CTSC	Target Folder (TST)	Targeting Services	Operations Planning Services	COI Services
JFC JFTSC	CTSC	Target Folder	Targeting Services	Operations Planning Services	COI Services

IER From	IER To	IE Product	User Service Definition Operational Capability	Technical Service Level 2	Technical Service Level 1
COMBINED AIR OPERATIONS CENTRE (CAOC) - AIR OPERATIONS COORDINATION CENTRE (LAND) (AOCC(L))					
CAOC	AOCC(L)	ASSESSREP	Intent & Guidance	Joint Services	COI Services
CAOC	AOCC(L)	RAP	Situational Awareness	Air Services	COI Services
AOCC(L)	CAOC	SITREP	Reports	Joint Services	COI Services
BI-DIRECTIONAL					
CAOC	AOCC(L)	Voice (Secure)	Voice	Audio-Based Communication Services	Core Services
CAOC	AOCC(L)	Formal Message	Formal Messaging	Military Messaging Service	Core Services
CAOC	AOCC(L)	Informal Message	Informal Messaging	Informal Messaging Services	Core Services
CAOC	AOCC(L)	Instant Message	Instant Messaging	Text-Based Collaboration Services	Core Services
CAOC	AOCC(L)	Office Collaboration (Audio)	Collaboration	Audio-Based Communication Services	Core Services
CAOC	AOCC(L)	Office Collaboration (AV)	Collaboration	Video-Based Communication Services	Core Services
CAOC	AOCC(L)	Office Collaboration (Chat)	Collaboration	Text-Based Collaboration Services	Core Services
CAOC	AOCC(L)	VTC	VTC	Video Based Collaboration Services	Core Services

NATO UNCLASSIFIED
DRAFT

ANNEX C TO
 MC 0640

IER From	IER To	IE Product	User Service Definition Operational Capability	Technical Service Level 2	Technical Service Level 1
CAOC	AOCC(L)	Airspace Control Measures	Airspace Management Services	Air Services	Core Services
CORPS TARGET SUPPORT CELL (TSC)- AIR OPERATIONS COORDINATION CENTRE (LAND) (AOCC(L))					
CTSC	AOCC(L)	Airspace Control Measures	Airspace Management Services	Air Services	Core Services
CTSC	AOCC(L)	SITREP	Reports	Air Services	Core Services
AOCC(L)	CTSC	ASSESSREP	Intent & Guidance	Joint Services	COI Services
BI-DIRECTIONAL					
CTSC	AOCC(L)	Voice (Secure)	Voice	Audio-Based Communication Services	Core Services
CTSC	AOCC(L)	Informal Message	Informal Messaging	Informal Messaging Services	Core Services
CTSC	AOCC(L)	Instant Message	Instant Messaging	Text-Based Collaboration Services	Core Services
CTSC	AOCC(L)	Office Collaboration (Audio)	Collaboration	Audio-Based Communication Services	Core Services
CTSC	AOCC(L)	Office Collaboration (AV)	Collaboration	Video-Based Communication Services	Core Services
CTSC	AOCC(L)	Office Collaboration (Chat)	Collaboration	Text-Based Collaboration Services	Core Services

IER From	IER To	IE Product	User Service Definition Operational Capability	Technical Service Level 2	Technical Service Level 1
CORPS TARGET SUPPORT CELL (CTSC)- BRIGADE JOINT FIRES CELL (BJFC)					
CTSC	BJFC	HPTL	Targeting Services	Operations Planning Services	COI Services
CTSC	BJFC	PTL	Targeting Services	Operations Planning Services	COI Services
CTSC	BJFC	TEA	Targeting Services	Operations Planning Services	COI Services
CTSC	BJFC	METEOC Info	Meteorology Services	Environmental Services	COI Services
CTSC	BJFC	NSL	Targeting Services	Operations Planning Services	COI Services
CTSC	BJFC	RTL	Targeting Services	Operations Planning Services	COI Services
CTSC	BJFC	Target Management	Targeting Services	Operations Planning Services	COI Services
CTSC	BJFC	Battlefield Control Measures	Maneuver Planning Services	LAND Services	COI Services
CTSC	BJFC	Fire Plan Orders	Targeting Services	Operations Planning Services	COI Services
BJFC	CTSC	Status Reports	Reports	LAND Services	COI Services
BJFC	CTSC	BDA	Reports	Tasking & Order Services	COI Services
BJFC	CTSC	TNL	Targeting Services	Operations Planning Services	COI Services

NATO UNCLASSIFIED
DRAFT

ANNEX C TO
MC 0640

IER From	IER To	IE Product	User Service Definition Operational Capability	Technical Service Level 2	Technical Service Level 1
BI-DIRECTIONAL					
CTSC	BJFC	Voice (Secure)	Voice	Audio-Based Communication Services	Core Services
CTSC	BJFC	Formal Message	Formal Messaging	Military Messaging Service	Core Enterprise Services
CTSC	BJFC	Informal Message	Informal Messaging	Informal Messaging Services	Core Services
CTSC	BJFC	Instant Message	Instant Messaging	Text-Based Collaboration Services	Core Services
CTSC	BJFC	Office Collaboration (Audio)	Collaboration	Audio-Based Communication Services	Core Services
CTSC	BJFC	Office Collaboration (AV)	Collaboration	Video-Based Communication Services	Core Services
CTSC	BJFC	Office Collaboration (Chat)	Collaboration	Text-Based Collaboration Services	Core Services
CTSC	BJFC	VTC	VTC	Video Based Collaboration Services	Core Services
CTSC	BJFC	Target Folder (TST)	Targeting Services	Operations Planning Services	COI Services
CTSC	BJFC	Target Folder	Targeting Services	Operations Planning Services	COI Services
CTSC	BJFC	RFI	Requests & Responses	LAND Services	COI Services

IER From	IER To	IE Product	User Service Definition Operational Capability	Technical Service Level 2	Technical Service Level 1
CTSC	BJFC	CCT	Targeting Services	Operations Planning Services	COI Services
BRIGADE JOINT FIRES CELL (BJFC) - VERY HIGH READINESS JOINT TASK FORCE INTELLIGENCE SURVEILLANCE RECONNAISSANCE RESOURCES (VJTF ISR)					
BJFC	VJTF ISR	Target Info Requests	Targeting Services	Operations Planning Services	COI Services
BJFC	VJTF ISR	Target Info Reports	Targeting Services	Operations Planning Services	COI Services
VJTF ISR	BJFC	BDA	Reports	Tasking & Order Services	COI Services
BI-DIRECTIONAL					
CCIR Man	Th ISR Res	Voice (Secure)	Voice	Audio-Based Communication Services	Core Services
CCIR Man	Th ISR Res	Instant Message	Instant Messaging	Text-Based Collaboration Services	Core Services
BRIGADE JOINT FIRES CELL (BJFC) - BRIGADE FIRE DIRECTION CENTRE (BFDC)					
BJFC	BFDC	Call For Fire	Targeting Services	Operations Planning Services	COI Services
BJFC	BFDC	Fire Plan Orders	Targeting Services	Operations Planning Services	COI Services
BJFC	BFDC	Deployment Commands	Tasking & Orders	Operations Planning Services	COI Services
BJFC	BFDC	ASSESSREP	Intent & Guidance	Joint Services	COI Services
BJFC	BFDC	METEOC Info	Meteorology Services	Environmental Services	COI Services

IER From	IER To	IE Product	User Service Definition Operational Capability	Technical Service Level 2	Technical Service Level 1
BFDC	BJFC	Target Info Requests	Targeting Services	Operations Planning Services	COI Services
BFDC	BJFC	Fire Unit Status Reports	Reports	Operations Planning Services	COI Services
BFDC	BJFC	Ammo Status Reports	Reports	Logistics Services	COI Services
BFDC	BJFC	SITREP	Reports	Joint Services	COI Services
BI-DIRECTIONAL					
BJFC	BFDC	Voice (Secure)	Voice	Audio-Based Communication Services	Core Services
BJFC	BFDC	Informal Message	Informal Messaging	Informal Messaging Services	Core Services
BJFC	BFDC	Instant Message	Instant Messaging	Text-Based Collaboration Services	Core Services
BJFC	BFDC	Target Folder (TST)	Targeting Services	Operations Planning Services	COI Services
BJFC	BFDC	Target Folder	Targeting Services	Operations Planning Services	COI Services
BRIGADE JOINT FIRES CELL (BJFC) - DEEP BATTLE ARTILLERY WEAPON SYSTEMS (DBAWS)					
BI-DIRECTIONAL					
BJFC	DBAWS	Voice (Secure)	Voice	Audio-Based Communication Services	Core Services
BJFC	DBAWS	Informal Message	Informal Messaging	Informal Messaging Services	Core Services

IER From	IER To	IE Product	User Service Definition Operational Capability	Technical Service Level 2	Technical Service Level 1
BJFC	DBAWS	Instant Message	Instant Messaging	Text-Based Collaboration Services	Core Services
BRIGADE JOINT FIRES CELL (BJFC) - CLOSE BATTERY ARTILLERY GUNS (CBAG)					
BI-DIRECTIONAL					
BJFC	CBAG	Voice (Secure)	Voice	Audio-Based Communication Services	Core Services
BJFC	CBAG	Informal Message	Informal Messaging	Informal Messaging Services	Core Services
BJFC	CBAG	Instant Message	Instant Messaging	Text-Based Collaboration Services	Core Services
BRIGADE JOINT FIRES CELL (BJFC) - BRIGADE AIR SUPPORT OFFICER (BASO)					
BJFC	BASO	ASSESSREP	Intent & Guidance	Joint Services	COI Services
BASO	BJFC	Airspace Control Measures	Airspace Management Services	Air Services	Core Services
BASO	BJFC	SITREP	Reports	Joint Services	COI Services
BI-DIRECTIONAL					
BJFC	BASO	Voice (Secure)	Voice	Audio-Based Communication Services	Core Services
BJFC	BASO	Instant Message	Instant Messaging	Text-Based Collaboration Services	Core Services
BJFC	BASO	Informal Message	Informal Messaging	Informal Messaging Services	Core Services
BRIGADE JOINT FIRES CELL (BJFC)-BATTLEGROUP JOINT FIRES CELL (BGJFC)					
BJFC	BGJFC	ASSESSREP	Intent & Guidance	Joint Services	COI Services

NATO UNCLASSIFIED
DRAFT

ANNEX C TO
MC 0640

IER From	IER To	IE Product	User Service Definition Operational Capability	Technical Service Level 2	Technical Service Level 1
BJFC	BGIFC	METEOC Info	Meteorology Services	Environmental Services	COI Services
BGIFC	BJFC	BDA	Reports	Tasking & Order Services	COI Services
BGIFC	BJFC	Call For Fire	Targeting Services	Operations Planning Services	COI Services
BGIFC	BJFC	SITREP	Reports	Joint Services	COI Services
BGIFC	BJFC	TNL	Targeting Services	Operations Planning Services	COI Services
BI-DIRECTIONAL					
BJFC	BGIFC	Voice (Secure)	Voice	Audio-Based Communication Services	Core Services
BJFC	BGIFC	Instant Message	Instant Messaging	Text-Based Collaboration Services	Core Services
BJFC	BGIFC	Informal Message	Informal Messaging	Informal Messaging Services	Core Services
BJFC	BGIFC	RFI	Requests & Responses	LAND Services	COI Services
BRIGADE JOINT FIRES CELL (BJFC) - COMPANY LEVEL FIRE SUPPORT TEAM (CFST)					
CFST	BJFC	Call For Fire	Targeting Services	Operations Planning Services	COI Services
BI-DIRECTIONAL					
BJFC	CFST	Voice (Secure)	Voice	Audio-Based Communication Services	Core Services
BJFC	CFST	Instant Message	Instant Messaging	Text-Based Collaboration Services	Core Services

IER From	IER To	IE Product	User Service Definition Operational Capability	Technical Service Level 2	Technical Service Level 1
BATTLEGROUP JOINT FIRES CELL (BJFC) - COMPANY LEVEL FIRE SUPPORT TEAM (CFST)					
BGJFC	CFST	RTO Reports	Targeting Services	Operations Planning Services	COI Services
BGJFC	CFST	Target Information Requests	Targeting Services	Operations Planning Services	COI Services
BGJFC	CFST	ASSESSREP	Intent & Guidance	Joint Services	COI Services
CFST	BGIFC	Call For Fire	Targeting Services	Operations Planning Services	COI Services
CFST	BGIFC	Target Information Reports	Targeting Services	Operations Planning Services	COI Services
CFST	BGIFC	BDA	Reports	Tasking & Order Services	COI Services
CFST	BGIFC	SITREP	Reports	Joint Services	COI Services
BI-DIRECTIONAL					
BGJFC	CFST	Voice (Secure)	Voice	Audio-Based Communication Services	Core Services
BGJFC	CFST	Instant Message	Instant Messaging	Text-Based Collaboration Services	Core Services
BGJFC	CFST	RFI	Requests & Responses	LAND Services	COI Services
BRIGADE FIRE DIRECTION CENTRE (BFDC) - BATTLEGROUP JOINT FIRES CELL (BGJFC)					
BFDC	BGIFC	RTO Reports	Targeting Services	Operations Planning Services	COI Services
BGJFC	BFDC	BDA	Reports	Tasking & Order Services	COI Services

NATO UNCLASSIFIED
DRAFT

ANNEX C TO
MC 0640

IER From	IER To	IE Product	User Service Definition Operational Capability	Technical Service Level 2	Technical Service Level 1
BI-DIRECTIONAL					
BGJFC	CFST	Voice (Secure)	Voice	Audio-Based Communication Services	Core Services
BGJFC	CFST	Instant Message	Instant Messaging	Text-Based Collaboration Services	Core Services
BGJFC	CFST	Informal Message	Informal Messaging	Informal Messaging Services	Core Services
BGJFC	CFST	RFI	Requests & Responses	LAND Services	COI Services
BRIGADE FIRE DIRECTION CENTRE (BFDC) - CLOSE BATTLE ARTILLERY GUNS (CBAG)					
CBAG	BFDC	Target Information Requests	Targeting Services	Operations Planning Services	COI Services
BFDC	CBAG	Fire Missions	Targeting Services	Operations Planning Services	COI Services
BFDC	CBAG	Deployment Commands	Tasking & Orders	Operations Planning Services	COI Services
BFDC	CBAG	Target Management	Targeting Services	Operations Planning Services	COI Services
BFDC	CBAG	ASSESSREP	Intent & Guidance	Joint Services	COI Services
BFDC	CBAG	METEOC Info	Meteorology Services	Environmental Services	COI Services
CBAG	BFDC	Target Information Reports	Targeting Services	Operations Planning Services	COI Services
CBAG	BFDC	Fire Unit Status Reports	Reports	Operations Planning Services	COI Services
CBAG	BFDC	Ammo Status Reports	Reports	Logistics Services	COI Services

NATO UNCLASSIFIED
DRAFT

ANNEX C TO
 MC 0640

IER From	IER To	IE Product	User Service Definition Operational Capability	Technical Service Level 2	Technical Service Level 1
CBAG	BFDC	SITREP	Reports	Joint Services	COI Services
CBAG	BFDC	RTO Reports	Targeting Services	Operations Planning Services	COI Services
BI-DIRECTIONAL					
BGJFC	CFST	Voice (Secure)	Voice	Audio-Based Communication Services	Core Services
BGJFC	CFST	Informal Message	Informal Messaging	Informal Messaging Services	Core Services
BGJFC	CFST	Instant Message	Instant Messaging	Text-Based Collaboration Services	Core Services
BRIGADE FIRE DIRECTION CENTRE (BFDC) - DEEP BATTLE ARTILERY WEAPON SYSTEMS (DBAWS)					
BFDC	DBAWS	Target Information Requests	Targeting Services	Operations Planning Services	COI Services
BFDC	DBAWS	Fire Missions	Targeting Services	Operations Planning Services	COI Services
BFDC	DBAWS	Deployment Commands	Tasking & Orders	Operations Planning Services	COI Services
BFDC	DBAWS	Target Management	Targeting Services	Operations Planning Services	COI Services
BFDC	DBAWS	ASSESSREP	Intent & Guidance	Joint Services	COI Services
BFDC	DBAWS	METEOC Info	Meteorology Services	Environmental Services	COI Services
DBAWS	BFDC	Target Information Reports	Targeting Services	Operations Planning Services	COI Services
DBAWS	BFDC	Fire Unit Status Reports	Reports	Operations Planning Services	COI Services

IER From	IER To	IE Product	User Service Definition Operational Capability	Technical Service Level 2	Technical Service Level 1
DBAWS	BFDC	Ammo Status Reports	Reports	Logistics Services	COI Services
DBAWS	BFDC	SITREP	Reports	Joint Services	COI Services
DBAWS	BFDC	RTO Reports	Targeting Services	Operations Planning Services	COI Services
BI-DIRECTIONAL					
BGJFC	CFST	Voice (Secure)	Voice	Audio-Based Communication Services	Core Services
BGJFC	CFST	Informal Message	Informal Messaging	Informal Messaging Services	Core Services
BGJFC	CFST	Instant Message	Instant Messaging	Text-Based Collaboration Services	Core Services
DEEP BATTLE ARTILERY WEAPON SYSTEMS (DBAWS) - AMMUNITION CONTROL POINT (ACP)					
DBAWS	ACP	Ammunition Status Reports	Reports	Logistics Services	COI Services
DBAWS	ACP	MATDEM	Requests & Responses	Logistics Services	COI Services
ACP	DBAWS	Resup Plan	Plans	Logistics Services	COI Services
BI-DIRECTIONAL					
DBAWS	ACP	Voice (Secure)	Voice	Audio-Based Communication Services	Core Services
DBAWS	ACP	Instant Message	Instant Messaging	Text-Based Collaboration Services	Core Services

IER From	IER To	IE Product	User Service Definition Operational Capability	Technical Service Level 2	Technical Service Level 1
CLOSE BATTLE ARTILLERY GUNS (CBAG) - AMMUNITION CONTROL POINT (ACP)					
DBAWS	ACP	Ammunition Status Reports	Reports	Logistics Services	COI Services
DBAWS	ACP	MATDEM	Requests & Responses	Logistics Services	COI Services
ACP	DBAWS	Resup Plan	Plans	Logistics Services	COI Services
BI-DIRECTIONAL					
DBAWS	ACP	Voice (Secure)	Voice	Audio-Based Communication Services	Core Services
DBAWS	ACP	Instant Message	Instant Messaging	Text-Based Collaboration Services	Core Services
AIR OPERATIONS COORDINATION CENTRE (LAND) (AOCC(L)) - BRIGADE AIR SUPPORT OFFICER (BASO)					
BI-DIRECTIONAL					
AOCC(L)	BASO	Voice (Secure)	Voice	Audio-Based Communication Services	Core Services
AOCC(L)	BASO	Instant Message	Instant Messaging	Text-Based Collaboration Services	Core Services
AOCC(L)	BASO	Informal Message	Informal Messaging	Informal Messaging Services	Core Services
AOCC(L)	BASO	Airspace Control Measures	Airspace Management Services	Air Services	Core Services
BRIGADE AIR SUPPORT OFFICER (BASO) - FORWARD AIR CONTROLLER (FAC)					
BASO	FAC	ASSESSREP	Intent & Guidance	Joint Services	COI Services
FAC	BASO	SITREP	Reports	Joint Services	COI Services

IER From	IER To	IE Product	User Service Definition Operational Capability	Technical Service Level 2	Technical Service Level 1
BI-DIRECTIONAL					
BASO	FAC	Voice (Secure)	Voice	Audio-Based Communication Services	Core Services
BASO	FAC	Instant Message	Instant Messaging	Text-Based Collaboration Services	Core Services
BASO	FAC	Airspace Control Measures	Airspace Management Services	Air Services	Core Services

Table: C-4: Fire Support in a VJTF(L) Scenario Product Dissemination and Consumption

MJO+ FIRE SUPPORT IER

16. Specific C2 and H2H information product exchange to enable the effective Fire Support to be provided in the land environment during a MJO+ scenario is depicted in Figure C-6. The unidirectional red and green arrows represent products either consumed or disseminated from Fire Support entities within the land environment. The bi-directional black arrows represent products that are both disseminated and consumed by Fire Support entities in support of a Land based deployment.

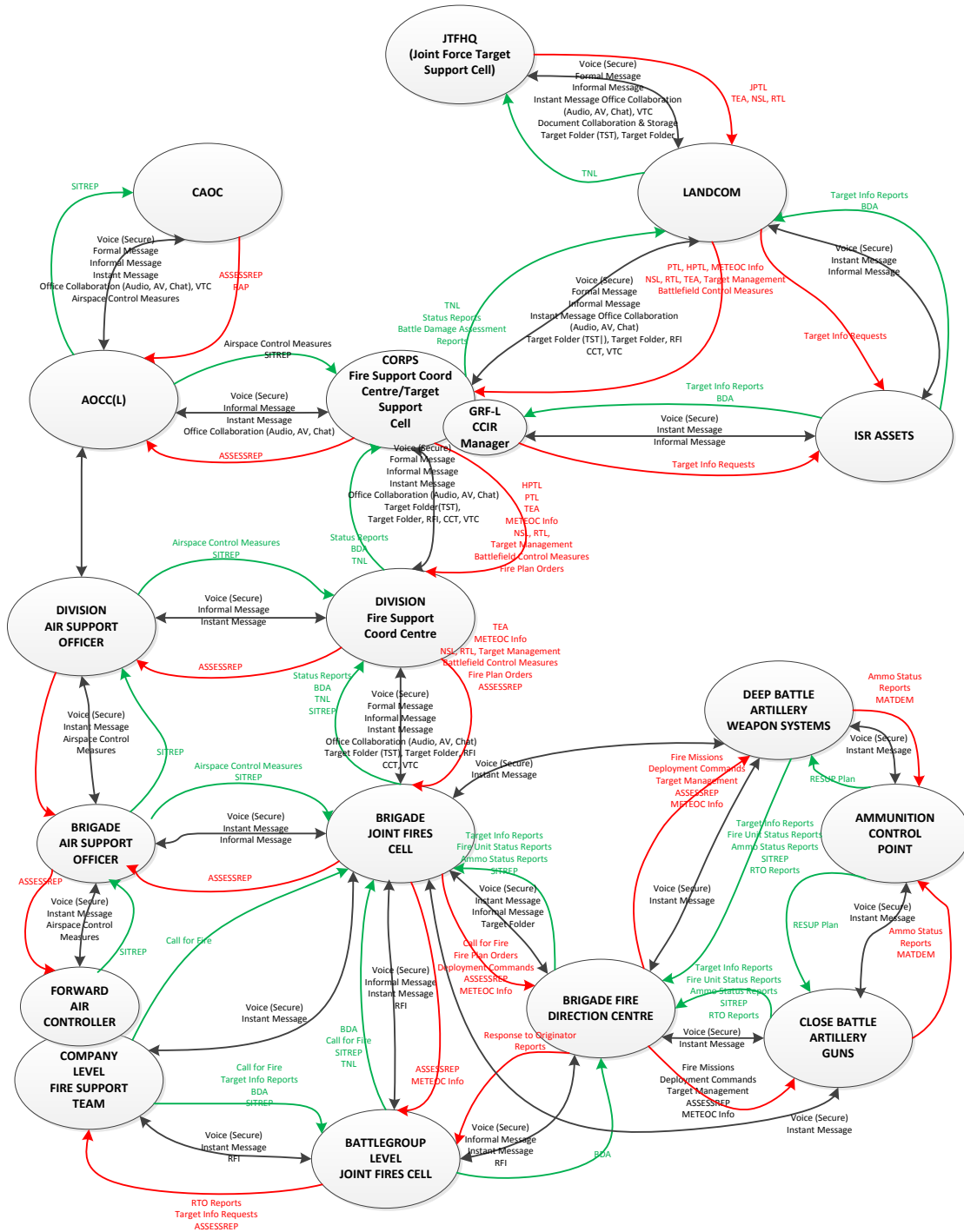

Figure C-6: MJO+ Fire Support Product Dissemination/Consumption

17. As introduced in Figure C-6, the products depicted in the Table C-5 details the unidirectional and bi-directional products relating to the Fire Support process within a land environment under a MJO+ scenario. The column 'IER From' and 'IER To' details the C2 entities which the information products are exchanged with, the third column lists the product that is exchanged. Column 4 lists the operational capability that the product supports and columns 5 - 6 map the product to the service type as detailed in the C3 Taxonomy nomenclature:

IER From	IER To	IE Product	User Service Definition Operational Capability	Technical Service Level 2	Technical Service Level 1
JOINT FORCE TARGET SUPPORT CELL (JFTSC) - LAND COMMAND (LANDCOM)					
JFTSC	LANDCOM	JPTL	Targeting Services	Operations Planning Services	COI Services
JFTSC	LANDCOM	TEA	Targeting Services	Operations Planning Services	COI Services
JFTSC	LANDCOM	NSL	Targeting Services	Operations Planning Services	COI Services
JFTSC	LANDCOM	RTL	Targeting Services	Operations Planning Services	COI Services
LANDCOM	JFTSC	TNL	Targeting Services	Operations Planning Services	COI Services
BI-DIRECTIONAL					
JFTSC	LANDCOM	Voice (Secure)	Voice	Audio-Based Communication Services	Core Services
JFTSC	LANDCOM	Formal Message	Formal Messaging	Military Messaging Service	Core Services

IER From	IER To	IE Product	User Service Definition Operational Capability	Technical Service Level 2	Technical Service Level 1
JFTSC	LANDCOM	Informal Message	Informal Messaging	Informal Messaging Services	Core Services
JFTSC	LANDCOM	Instant Message	Instant Messaging	Text-Based Collaboration Services	Core Services
JFTSC	LANDCOM	Office Collaboration (Audio)	Collaboration	Audio-Based Communication Services	Core Services
JFTSC	LANDCOM	Office Collaboration (AV)	Collaboration	Video-Based Communication Services	Core Services
JFTSC	LANDCOM	Office Collaboration (Chat)	Collaboration	Text-Based Collaboration Services	Core Services
JFTSC	LANDCOM	Document Collaboration & Storage	Content Management Services	Information Management	COI Services
JFTSC	LANDCOM	VTC	VTC	Video Based Collaboration Services	Core Services
JFTSC	LANDCOM	Target Folder (TST)	Targeting Services	Operations Planning Services	COI Services
JFTSC	LANDCOM	Target Folder	Targeting Services	Operations Planning Services	COI Services
LAND COMMAND (LANDCOM) - CORPS FIRE SUPPORT COORDINATION CENTRE/TARGET SUPPORT CELL (CFSCC/TSC)					
LANDCOM	CFSCC/TSC	PTL	Targeting Services	Operations Planning Services	COI Services
LANDCOM	CFSCC/TSC	HPTL	Targeting Services	Operations Planning Services	COI Services

IER From	IER To	IE Product	User Service Definition Operational Capability	Technical Service Level 2	Technical Service Level 1
LANDCOM	CFSCC/TSC	METEOC Info	Meteorology Services	Environmental Services	COI Services
LANDCOM	CFSCC/TSC	NSL	Targeting Services	Operations Planning Services	COI Services
LANDCOM	CFSCC/TSC	RTL	Targeting Services	Operations Planning Services	COI Services
LANDCOM	CFSCC/TSC	TEA	Targeting Services	Operations Planning Services	COI Services
LANDCOM	CFSCC/TSC	Target Management	Targeting Services	Operations Planning Services	COI Services
LANDCOM	CFSCC/TSC	Battlefield Control Measures	Maneuver Planning Services	LAND Services	COI Services
CFSCC/TSC	LANDCOM	TNL	Targeting Services	Operations Planning Services	COI Services
CFSCC/TSC	LANDCOM	Status Reports	Reports	LAND Services	COI Services
CFSCC/TSC	LANDCOM	BDA	Reports	Tasking & Order Services	COI Services
BI-DIRECTIONAL					
LANDCOM	CFSCC/TSC	Voice (Secure)	Voice	Audio-Based Communication Services	Core Services
LANDCOM	CFSCC/TSC	Formal Message	Formal Messaging	Military Messaging Service	Core Services
LANDCOM	CFSCC/TSC	Informal Message	Informal Messaging	Informal Messaging Services	Core Services
LANDCOM	CFSCC/TSC	VTC	VTC	Video Based Collaboration Services	Core Services

NATO UNCLASSIFIED
DRAFT

ANNEX C TO
MC 0640

IER From	IER To	IE Product	User Service Definition Operational Capability	Technical Service Level 2	Technical Service Level 1
LANDCOM	CFSCC/TSC	Instant Message	Instant Messaging	Text-Based Collaboration Services	Core Services
LANDCOM	CFSCC/TSC	Office Collaboration (Audio)	Collaboration	Audio-Based Communication Services	Core Services
LANDCOM	CFSCC/TSC	Office Collaboration (AV)	Collaboration	Video-Based Communication Services	Core Services
LANDCOM	CFSCC/TSC	Office Collaboration (Chat)	Collaboration	Text-Based Collaboration Services	Core Services
LANDCOM	CFSCC/TSC	Target Folder (TST)	Targeting Services	Operations Planning Services	COI Services
LANDCOM	CFSCC/TSC	Target Folder	Targeting Services	Operations Planning Services	COI Services
LANDCOM	CFSCC/TSC	RFI	Requests & Responses	LAND Services	COI Services
LANDCOM	CFSCC/TSC	CCT	Targeting Services	Operations Planning Services	COI Services
COMBINED AIR OPERATIONS CENTRE (CAOC) - AIR OPERATIONS COORDINATION CENTRE (LAND) (AOCC(L))					
CAOC	AOCC(L)	ASSESSREP	Intent & Guidance	Joint Services	COI Services
CAOC	AOCC(L)	RAP	Situational Awareness	Air Services	COI Services
AOCC(L)	CAOC	SITREP	Reports	Joint Services	COI Services
BI-DIRECTIONAL					
CAOC	AOCC(L)	Voice (Secure)	Voice	Audio-Based Communication Services	Core Services

IER From	IER To	IE Product	User Service Definition Operational Capability	Technical Service Level 2	Technical Service Level 1
CAOC	AOCC(L)	Formal Message	Formal Messaging	Military Messaging Service	Core Services
CAOC	AOCC(L)	Informal Message	Informal Messaging	Informal Messaging Services	Core Services
CAOC	AOCC(L)	Instant Message	Instant Messaging	Text-Based Collaboration Services	Core Services
CAOC	AOCC(L)	Office Collaboration (Audio)	Collaboration	Audio-Based Communication Services	Core Services
CAOC	AOCC(L)	Office Collaboration (AV)	Collaboration	Video-Based Communication Services	Core Services
CAOC	AOCC(L)	Office Collaboration (Chat)	Collaboration	Text-Based Collaboration Services	Core Services
CAOC	AOCC(L)	VTC	VTC	Video Based Collaboration Services	Core Services
CAOC	AOCC(L)	Airspace Control Measures	Airspace Management Services	Air Services	Core Services
CORPS FIRE SUPPORT COORDINATION CENTRE/TARGET SUPPORT (CFSCC/TSC) - AIR OPERATIONS COORDINATION CENTRE (LAND) (AOCC(L))					
CFSCC/TSC	AOCC(L)	Airspace Control Measures	Airspace Management Services	Air Services	Core Services
CFSCC/TSC	AOCC(L)	SITREP	Reports	Air Services	Core Services
AOCC(L)	CFSCC/TSC	ASSESSREP	Intent & Guidance	Joint Services	COI Services

NATO UNCLASSIFIED
DRAFT

ANNEX C TO
 MC 0640

IER From	IER To	IE Product	User Service Definition Operational Capability	Technical Service Level 2	Technical Service Level 1
BI-DIRECTIONAL					
CFSCC/TSC	AOCC(L)	Voice (secure)	Voice	Audio-Based Communication Services	Core Services
CFSCC/TSC	AOCC(L)	Informal Message	Informal Messaging	Informal Messaging Services	Core Services
CFSCC/TSC	AOCC(L)	Instant Message	Instant Messaging	Text-Based Collaboration Services	Core Services
CFSCC/TSC	AOCC(L)	Office Collaboration (Audio)	Collaboration	Audio-Based Communication Services	Core Services
CFSCC/TSC	AOCC(L)	Office Collaboration (AV)	Collaboration	Video-Based Communication Services	Core Services
CFSCC/TSC	AOCC(L)	Office Collaboration (Chat)	VTC	Video Based Collaboration Services	Core Services
CFSCC/TSC	AOCC(L)	Office Collaboration (Chat)	Collaboration	Text-Based Collaboration Services	Core Services
LANDCOM - ISR RESOURCES (ISR Res)					
LANDCOM	ISR Res	Target Info Requests	Targeting Services	Operations Planning Services	COI Services
LANDCOM	ISR Res	Target Info Reports	Targeting Services	Operations Planning Services	COI Services
ISR Res	LANDCOM	BDA	Reports	Tasking & Order Services	COI Services

NATO UNCLASSIFIED
DRAFT

ANNEX C TO
MC 0640

IER From	IER To	IE Product	User Service Definition Operational Capability	Technical Service Level 2	Technical Service Level 1
BI-DIRECTIONAL					
LANDCOM	ISR Res	Voice (Secure)	Voice	Audio-Based Communication Services	Core Services
LANDCOM	ISR Res	Instant Message	Instant Messaging	Text-Based Collaboration Services	Core Services
LANDCOM	ISR Res	Informal Message	Informal Messaging	Informal Messaging Services	Core Services
GRF-L COMMANDERS CRITICAL INFORMATION REQUIREMENT (CCIR) MANAGER - ISR RESOURCES (ISR Res)					
CCIR Man	ISR Res	Target Info Requests	Targeting Services	Operations Planning Services	COI Services
CCIR Man	ISR Res	Target Info Reports	Targeting Services	Operations Planning Services	COI Services
ISR Res	CCIR Man	BDA	Reports	Tasking & Order Services	COI Services
BI-DIRECTIONAL					
CCIR Man	ISR Res	Voice (Secure)	Voice	Audio-Based Communication Services	Core Services
CCIR Man	ISR Res	Instant Message	Instant Messaging	Text-Based Collaboration Services	Core Services
LANDCOM	ISR Res	Informal Message	Informal Messaging	Informal Messaging Services	Core Services

IER From	IER To	IE Product	User Service Definition Operational Capability	Technical Service Level 2	Technical Service Level 1
CORPS FIRE SUPPORT COORDINATION CENTRE/TARGET SUPPORT (CFSCC/TSC) - DIVISION FIRE SUPPORT COORDINATION CENTRE (DFSCC)					
CFSCC/TSC	DFSCC	HPTL	Targeting Services	Operations Planning Services	COI Services
CFSCC/TSC	DFSCC	PTL	Targeting Services	Operations Planning Services	COI Services
CFSCC/TSC	DFSCC	TEA	Targeting Services	Operations Planning Services	COI Services
CFSCC/TSC	DFSCC	METEOC Info	Meteorology Services	Environmental Services	COI Services
CFSCC/TSC	DFSCC	NSL	Targeting Services	Operations Planning Services	COI Services
CFSCC/TSC	DFSCC	RTL	Targeting Services	Operations Planning Services	COI Services
CFSCC/TSC	DFSCC	Target Management	Targeting Services	Operations Planning Services	COI Services
CFSCC/TSC	DFSCC	Battlefield Control Measures	Maneuver Planning Services	LAND Services	COI Services
CFSCC/TSC	DFSCC	Fire Plan Orders	Targeting Services	Operations Planning Services	COI Services
DFSCC	CFSCC/TSC	Status Reports	Reports	LAND Services	COI Services
DFSCC	CFSCC/TSC	BDA	Reports	Tasking & Order Services	COI Services
DFSCC	CFSCC/TSC	TNL	Targeting Services	Operations Planning Services	COI Services

NATO UNCLASSIFIED
DRAFT

ANNEX C TO
 MC 0640

IER From	IER To	IE Product	User Service Definition Operational Capability	Technical Service Level 2	Technical Service Level 1
BI-DIRECTIONAL					
CFSCC/TSC	DFSCC	Voice (Secure)	Voice	Audio-Based Communication Services	Core Services
CFSCC/TSC	DFSCC	Formal Message	Formal Messaging	Military Messaging Service	Core Enterprise Services
CFSCC/TSC	DFSCC	Informal Message	Informal Messaging	Informal Messaging Services	Core Services
CFSCC/TSC	DFSCC	Instant Message	Instant Messaging	Text-Based Collaboration Services	Core Services
CFSCC/TSC	DFSCC	Office Collaboration (Audio)	Collaboration	Audio-Based Communication Services	Core Services
CFSCC/TSC	DFSCC	Office Collaboration (Chat)	VTC	Video Based Collaboration Services	Core Services
CFSCC/TSC	DFSCC	Office Collaboration (AV)	Collaboration	Video-Based Communication Services	Core Services
CFSCC/TSC	DFSCC	Office Collaboration (Chat)	Collaboration	Text-Based Collaboration Services	Core Services
CFSCC/TSC	DFSCC	VTC	VTC	Video Based Collaboration Services	Core Services
CFSCC/TSC	DFSCC	Target Folder (TST)	Targeting Services	Operations Planning Services	COI Services
CFSCC/TSC	DFSCC	Target Folder	Targeting Services	Operations Planning Services	COI Services

IER From	IER To	IE Product	User Service Definition Operational Capability	Technical Service Level 2	Technical Service Level 1
CFSCC/TSC	DFSCC	RFI	Requests & Responses	LAND Services	COI Services
CFSCC/TSC	DFSCC	CCT	Targeting Services	Operations Planning Services	COI Services
DIVISION FIRE SUPPORT COORDINATION CENTRE (DFSCC) - DIVISION AIR SUPPORT OFFICER (DASO)					
DFSCC	DASO	ASSESSREP	Intent & Guidance	Joint Services	COI Services
DASO	DFSCC	Airspace Control Measures	Airspace Management Services	Air Services	Core Services
DASO	DFSCC	SITREP	Reports	Joint Services	COI Services
BI-DIRECTIONAL					
DFSCC	DASO	Voice (Secure)	Voice	Audio-Based Communication Services	Core Services
DFSCC	DASO	Informal Message	Informal Messaging	Informal Messaging Services	Core Services
DFSCC	DASO	Instant Message	Instant Messaging	Text-Based Collaboration Services	Core Services
DIVISION FIRE SUPPORT COORDINATION CENTRE (DFSCC) - BRIGADE JOINT FIRES CELL (BJFC)					
DFSCC	BJFC	TEA	Targeting Services	Operations Planning Services	COI Services
DFSCC	BJFC	METEOC Info	Meteorology Services	Environmental Services	COI Services
DFSCC	BJFC	NSL	Targeting Services	Operations Planning Services	COI Services
DFSCC	BJFC	RTL	Targeting Services	Operations Planning Services	COI Services

IER From	IER To	IE Product	User Service Definition Operational Capability	Technical Service Level 2	Technical Service Level 1
DFSCC	BJFC	Target Management	JISR Imagery and Video Services	Operations Planning Services	COI Services
DFSCC	BJFC	Battlefield Control Measures	Maneuver Planning Services	LAND Services	COI Services
DFSCC	BJFC	Fire Plan Orders	Targeting Services	Operations Planning Services	COI Services
DFSCC	BJFC	ASSESSREP	Intent & Guidance	Joint Services	COI Services
BJFC	DFSCC	Status Reports	Reports	LAND Services	COI Services
BJFC	DFSCC	BDA	Reports	Tasking & Order Services	COI Services
BJFC	DFSCC	TNL	Targeting Services	Operations Planning Services	COI Services
BJFC	DFSCC	SITREP	Reports	Joint Services	COI Services
BI-DIRECTIONAL					
DFSCC	BJFC	Voice (Secure)	Voice	Audio-Based Communication Services	Core Services
DFSCC	BJFC	Formal Message	Formal Messaging	Military Messaging Service	Core Enterprise Services
DFSCC	BJFC	Informal Message	Informal Messaging	Informal Messaging Services	Core Services
DFSCC	BJFC	Instant Message	Instant Messaging	Text-Based Collaboration Services	Core Services
DFSCC	BJFC	Office Collaboration (Audio)	Collaboration	Audio-Based Communication Services	Core Services

IER From	IER To	IE Product	User Service Definition Operational Capability	Technical Service Level 2	Technical Service Level 1
DFSCC	BJFC	Office Collaboration (AV)	Collaboration	Video-Based Communication Services	Core Services
DFSCC	BJFC	Office Collaboration (Chat)	Collaboration	Text-Based Collaboration Services	Core Services
DFSCC	BJFC	VTC	VTC	Video Based Collaboration Services	Core Services
DFSCC	BJFC	Target Folder (TST)	Targeting Services	Operations Planning Services	COI Services
DFSCC	BJFC	Target Folder	Targeting Services	Operations Planning Services	COI Services
DFSCC	BJFC	RFI	Requests & Responses	LAND Services	COI Services
DFSCC	BJFC	CCT	Targeting Services	Operations Planning Services	COI Services
BRIGADE JOINT FIRES CELL (BJFC) - BRIGADE FIRE DIRECTION CENTRE (BFDC)					
BJFC	BFDC	Call For Fire	Targeting Services	Operations Planning Services	COI Services
BJFC	BFDC	Fire Plan Orders	Targeting Services	Operations Planning Services	COI Services
BJFC	BFDC	Deployment Commands	Tasking & Orders	Operations Planning Services	COI Services
BJFC	BFDC	ASSESSREP	Intent & Guidance	Joint Services	COI Services
BJFC	BFDC	METEOC Info	Meteorology Services	Environmental Services	COI Services
BFDC	BJFC	Target Info Requests	Targeting Services	Operations Planning Services	COI Services

IER From	IER To	IE Product	User Service Definition Operational Capability	Technical Service Level 2	Technical Service Level 1
BFDC	BJFC	Fire Unit Status Reports	Reports	Operations Planning Services	COI Services
BFDC	BJFC	Ammo Status Reports	Reports	Logistics Services	COI Services
BFDC	BJFC	SITREP	Reports	Joint Services	COI Services
BI-DIRECTIONAL					
BJFC	BFDC	Voice (Secure)	Voice	Audio-Based Communication Services	Core Services
BJFC	BFDC	Informal Message	Informal Messaging	Informal Messaging Services	Core Services
BJFC	BFDC	Instant Message	Instant Messaging	Text-Based Collaboration Services	Core Services
BJFC	BFDC	Target Folder	Targeting Services	Operations Planning Services	COI Services
BJFC	BFDC	Target Folder (TST)	Targeting Services	Operations Planning Services	COI Services
BRIGADE JOINT FIRES CELL (BJFC) - DEEP BATTLE ARTILLERY WEAPON SYSTEMS (DBAWS)					
BI-DIRECTIONAL					
BJFC	DBAWS	Voice (secure)	Voice	Audio-Based Communication Services	Core Services
BJFC	DBAWS	Instant Message	Instant Messaging	Text-Based Collaboration Services	Core Services

IER From	IER To	IE Product	User Service Definition Operational Capability	Technical Service Level 2	Technical Service Level 1
BRIGADE JOINT FIRES CELL (BJFC) - CLOSE BATTERY ARTILLERY GUNS (CBAG)					
BI-DIRECTIONAL					
BJFC	CBAG	Voice (secure)	Voice	Audio-Based Communication Services	Core Services
BJFC	CBAG	Informal Message	Informal Messaging	Informal Messaging Services	Core Services
BJFC	CBAG	Instant Message	Instant Messaging	Text-Based Collaboration Services	Core Services
BRIGADE JOINT FIRES CELL (BJFC) - BRIGADE AIR SUPPORT OFFICER (BASO)					
BJFC	BASO	ASSESSREP	Intent & Guidance	Joint Services	COI Services
BASO	BJFC	Airspace Control Measures	Airspace Management Services	Air Services	Core Services
BASO	BJFC	SITREP	Reports	Joint Services	COI Services
BI-DIRECTIONAL					
BJFC	BASO	Voice (secure)	Voice	Audio-Based Communication Services	Core Services
BJFC	BASO	Instant Message	Instant Messaging	Text-Based Collaboration Services	Core Services
BJFC	BASO	Informal Message	Informal Messaging	Informal Messaging Services	Core Services
BRIGADE JOINT FIRES CELL (BJFC)-BATTLEGROUP JOINT FIRES CELL (BGJFC)					
BJFC	BGJFC	ASSESSREP	Intent & Guidance	Joint Services	COI Services
BJFC	BGJFC	METEOC Info	Meteorology Services	Environmental Services	COI Services

IER From	IER To	IE Product	User Service Definition Operational Capability	Technical Service Level 2	Technical Service Level 1
BGIFC	BJFC	BDA	Reports	Tasking & Order Services	COI Services
BGIFC	BJFC	Call For Fire	Targeting Services	Operations Planning Services	COI Services
BGIFC	BJFC	SITREP	Reports	Joint Services	COI Services
BGIFC	BJFC	TNL	Targeting Services	Operations Planning Services	COI Services
BI-DIRECTIONAL					
BJFC	BGIFC	Voice (secure)	Voice	Audio-Based Communication Services	Core Services
BJFC	BGIFC	Instant Message	Instant Messaging	Text-Based Collaboration Services	Core Services
BJFC	BGIFC	Informal Message	Informal Messaging	Informal Messaging Services	Core Services
BJFC	BGIFC	RFI	Requests & Responses	LAND Services	COI Services
BRIGADE JOINT FIRES CELL (BJFC) - COMPANY LEVEL FIRE SUPPORT TEAM (CFST)					
CFST	BJFC	Call For Fire	Targeting Services	Operations Planning Services	COI Services
BI-DIRECTIONAL					
BJFC	CFST	Voice (secure)	Voice	Audio-Based Communication Services	Core Services
BJFC	CFST	Instant Message	Instant Messaging	Text-Based Collaboration Services	Core Services

IER From	IER To	IE Product	User Service Definition Operational Capability	Technical Service Level 2	Technical Service Level 1
BATTLEGROUP JOINT FIRES CELL (BJFC) - COMPANY LEVEL FIRE SUPPORT TEAM (CFST)					
BGJFC	CFST	RTO Reports	Targeting Services	Operations Planning Services	COI Services
BGJFC	CFST	Target Information Requests	Targeting Services	Operations Planning Services	COI Services
BGJFC	CFST	ASSESSREP	Intent & Guidance	Joint Services	COI Services
CFST	BGIFC	Call For Fire	Targeting Services	Operations Planning Services	COI Services
CFST	BGIFC	Target Information Reports	Targeting Services	Operations Planning Services	COI Services
CFST	BGIFC	BDA	Reports	Tasking & Order Services	COI Services
CFST	BGIFC	SITREP	Reports	Joint Services	COI Services
BI-DIRECTIONAL					
BGJFC	CFST	Voice (secure)	Voice	Audio-Based Communication Services	Core Services
BGJFC	CFST	Instant Message	Instant Messaging	Text-Based Collaboration Services	Core Services
BGJFC	CFST	RFI	Requests & Responses	LAND Services	COI Services
BRIGADE FIRE DIRECTION CENTRE (BFDC) - BATTLEGROUP JOINT FIRES CELL (BGJFC)					
BFDC	BGIFC	RTO Reports	Targeting Services	Operations Planning Services	COI Services
BGJFC	BFDC	BDA	Reports	Tasking & Order Services	COI Services

IER From	IER To	IE Product	User Service Definition Operational Capability	Technical Service Level 2	Technical Service Level 1
BI-DIRECTIONAL					
BGJFC	CFST	Voice (secure)	Voice	Audio-Based Communication Services	Core Services
BGJFC	CFST	Instant Message	Instant Messaging	Text-Based Collaboration Services	Core Services
BGJFC	CFST	Informal Message	Informal Messaging	Informal Messaging Services	Core Services
BGJFC	CFST	RFI	Requests & Responses	LAND Services	COI Services
BRIGADE FIRE DIRECTION CENTRE (BFDC) - CLOSE BATTLE ARTILLERY GUNS (CBAG)					
BFDC	CBAG	Target Information Requests	Targeting Services	Operations Planning Services	COI Services
BFDC	CBAG	Fire Missions	Targeting Services	Operations Planning Services	COI Services
BFDC	CBAG	Deployment Commands	Tasking & Orders	Operations Planning Services	COI Services
BFDC	CBAG	Target Management	Targeting Services	Operations Planning Services	COI Services
BFDC	CBAG	ASSESSREP	Intent & Guidance	Joint Services	COI Services
BFDC	CBAG	METEOC Info	Meteorology Services	Environmental Services	COI Services
CBAG	BFDC	Target Information Reports	Targeting Services	Operations Planning Services	COI Services
CBAG	BFDC	Fire Unit Status Reports	Reports	Operations Planning Services	COI Services
CBAG	BFDC	Ammo Status Reports	Reports	Logistics Services	COI Services
CBAG	BFDC	SITREP	Reports	Joint Services	COI Services

NATO UNCLASSIFIED
DRAFT

ANNEX C TO
MC 0640

IER From	IER To	IE Product	User Service Definition Operational Capability	Technical Service Level 2	Technical Service Level 1
CBAG	BFDC	RTO Reports	Targeting Services	Operations Planning Services	COI Services
BI-DIRECTIONAL					
BGJFC	CFST	Voice (secure)	Voice	Audio-Based Communication Services	Core Services
BGJFC	CFST	Informal Message	Informal Messaging	Informal Messaging Services	Core Services
BGJFC	CFST	Instant Message	Instant Messaging	Text-Based Collaboration Services	Core Services
BRIGADE FIRE DIRECTION CENTRE (BFDC) - DEEP BATTLE ARTILERY WEAPON SYSTEMS (DBAWS)					
BFDC	DBAWS	Target Information Requests	Targeting Services	Operations Planning Services	COI Services
BFDC	DBAWS	Fire Missions	Targeting Services	Operations Planning Services	COI Services
BFDC	DBAWS	Deployment Commands	Tasking & Orders	Operations Planning Services	COI Services
BFDC	DBAWS	Target Management	Targeting Services	Operations Planning Services	COI Services
BFDC	DBAWS	ASSESSREP	Intent & Guidance	Joint Services	COI Services
BFDC	DBAWS	METEOC Info	Meteorology Services	Environmental Services	COI Services
DBAWS	BFDC	Target Information Reports	Targeting Services	Operations Planning Services	COI Services
DBAWS	BFDC	Fire Unit Status Reports	Reports	Operations Planning Services	COI Services
DBAWS	BFDC	Ammo Status Reports	Reports	Logistics Services	COI Services

IER From	IER To	IE Product	User Service Definition Operational Capability	Technical Service Level 2	Technical Service Level 1
DBAWS	BFDC	SITREP	Reports	Joint Services	COI Services
DBAWS	BFDC	RTO Reports	Targeting Services	Operations Planning Services	COI Services
BI-DIRECTIONAL					
BGJFC	CFST	Voice (secure)	Voice	Audio-Based Communication Services	Core Services
BGJFC	CFST	Informal Message	Informal Messaging	Informal Messaging Services	Core Services
BGJFC	CFST	Instant Message	Instant Messaging	Text-Based Collaboration Services	Core Services
DEEP BATTLE ARTILERY WEAPON SYSTEMS (DBAWS) - AMMUNITION CONTROL POINT (ACP)					
DBAWS	ACP	Ammunition Status Reports	Reports	Logistics Services	COI Services
DBAWS	ACP	MATDEM	Requests & Responses	Logistics Services	COI Services
ACP	DBAWS	Resup Plan	Plans	Logistics Services	COI Services
BI-DIRECTIONAL					
DBAWS	ACP	Voice (secure)	Voice	Audio-Based Communication Services	Core Services
DBAWS	ACP	Instant Message	Instant Messaging	Text-Based Collaboration Services	Core Services
CLOSE BATTLE ARTILLERY GUNS (CBAG) - AMMUNITION CONTROL POINT (ACP)					
DBAWS	ACP	Ammunition Status Reports	Reports	Logistics Services	COI Services
DBAWS	ACP	MATDEM	Requests & Responses	Logistics Services	COI Services

IER From	IER To	IE Product	User Service Definition Operational Capability	Technical Service Level 2	Technical Service Level 1
ACP	DBAWS	Resup Plan	Plans	Logistics Services	COI Services
BI-DIRECTIONAL					
DBAWS	ACP	Voice (secure)	Voice	Audio-Based Communication Services	Core Services
DBAWS	ACP	Instant Message	Instant Messaging	Text-Based Collaboration Services	Core Services
AIR OPERATIONS COORDINATION CENTRE (LAND) (AOCC(L)) - DIVISION AIR SUPPORT OFFICER (DASO)					
BI-DIRECTIONAL					
AOCC(L)	DASO	Voice (secure)	Voice	Audio-Based Communication Services	Core Services
AOCC(L)	DASO	Instant Message	Instant Messaging	Text-Based Collaboration Services	Core Services
AOCC(L)	DASO	Informal Message	Informal Messaging	Informal Messaging Services	Core Services
AOCC(L)	DASO	Airspace Control Measures	Airspace Management Services	Air Services	Core Services
DIVISION AIR SUPPORT OFFICER (DASO) - BRIGADE AIR SUPPORT OFFICER (BASO)					
DASO	BASO	ASSESSREP	Intent & Guidance	Joint Services	COI Services
BASO	DASO	SITREP	Reports	Joint Services	COI Services
BI-DIRECTIONAL					
DASO	BASO	Voice (secure)	Voice	Audio-Based Communication Services	Core Services

NATO UNCLASSIFIED
DRAFT

ANNEX C TO
 MC 0640

IER From	IER To	IE Product	User Service Definition Operational Capability	Technical Service Level 2	Technical Service Level 1
DASO	BASO	Instant Message	Instant Messaging	Text-Based Collaboration Services	Core Services
DASO	BASO	Airspace Control Measures	Airspace Management Services	Air Services	Core Services
BRIGADE AIR SUPPORT OFFICER (BASO) - FORWARD AIR CONTROLLER (FAC)					
BASO	FAC	ASSESSREP	Intent & Guidance	Joint Services	COI Services
FAC	BASO	SITREP	Reports	Joint Services	COI Services
BI-DIRECTIONAL					
BASO	FAC	Voice (secure)	Voice	Audio-Based Communication Services	Core Services
BASO	FAC	Instant Message	Instant Messaging	Text-Based Collaboration Services	Core Services
BASO	FAC	Airspace Control Measures	Airspace Management Services	Air Services	Core Services

Table C-5: Fire Support in a MJO+ Scenario Product Dissemination and Consumption

VJTF(L) LOGISTICS SUPPORT IER

18. Specific C2 and H2H information product exchange to enable the effective Logistics Support to be provided in the land environment during a VJTF(L) scenario is depicted in Figure C-7. The unidirectional red and green arrows represent products either consumed or disseminated from Logistics entities within the land environment. The bi-directional black arrows represent products that are both disseminated and consumed by Logistics entities deployed in support of a Land based deployment:

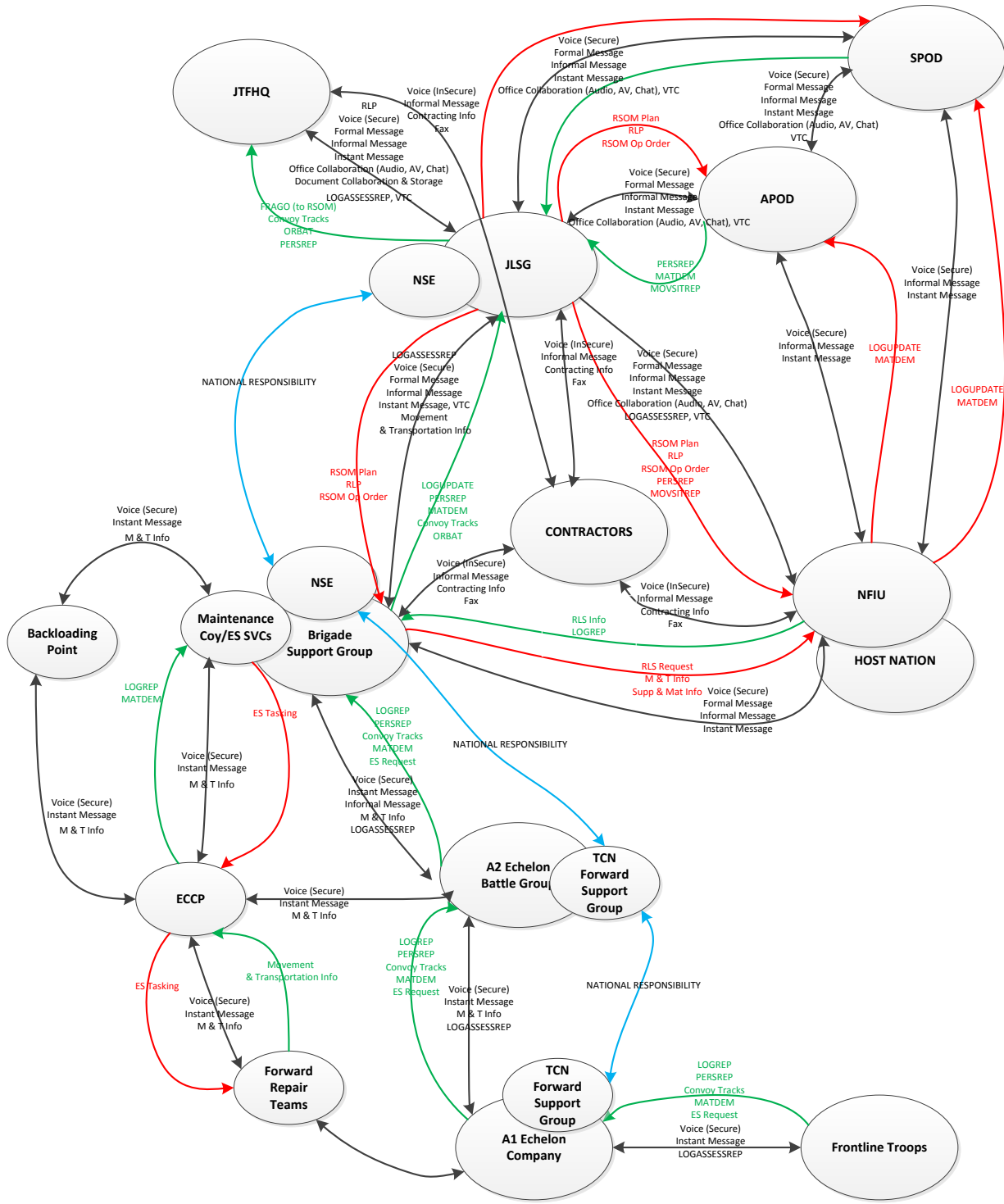

Figure C-7: VJTF(L) Logistics Support Product Dissemination/Consumption

NATO UNCLASSIFIED
DRAFT

ANNEX C TO
 MC 0640

19. As introduced in Figure C-7, the products depicted in the Table C-6 details the unidirectional and bi-directional products relating to the Logistics support process within a land environment under a VJTF(L) scenario. The column 'IER From' and 'IER To' details the C2 entities which the information products are exchanged with; the third column lists the product that is exchanged. Column 4 lists the operational capability that the product supports and columns 5 - 6 map the product to the service type as detailed in the C3 Taxonomy nomenclature:

IER From	IER To	IE Product	User Service Definition Operational Capability	Technical Service Level 2	Technical Service Level 1
JOINT TASK FORCE HEADQUARTERS (JTF HQ) - JOINT LOGISTICS SUPPORT GROUP (JLSG)					
JLSG	JTF HQ	FRAGO (to RSOM)	Tasking & Orders	Joint Services	COI Services
JLSG	JTF HQ	Convoy Tracks	Live Tracks	Battlespace Information Services	COI Services
JLSG	JTF HQ	ORBAT	Situational Awareness	Situational Awareness Service	COI Services
JLSG	JTF HQ	PERSREP	Reports	Logistics Services	COI Services
BI-DIRECTIONAL					
JTF HQ	JLSG	Voice (Secure)	Voice	Audio-Based Communication Services	Core Services
JTF HQ	JLSG	Formal Message	Formal Messaging	Military Messaging Service	Core Services
JTF HQ	JLSG	Informal Message	Informal Messaging	Informal Messaging Services	Core Services

IER From	IER To	IE Product	User Service Definition Operational Capability	Technical Service Level 2	Technical Service Level 1
JTF HQ	JLSG	Instant Message	Instant Messaging	Text-Based Collaboration Services	Core Services
JTF HQ	JLSG	Office Collaboration (Audio)	Collaboration	Audio-Based Communication Services	Core Services
JTF HQ	JLSG	Office Collaboration (AV)	Collaboration	Video-Based Communication Services	Core Services
JTF HQ	JLSG	Office Collaboration (Chat)	Collaboration	Text-Based Collaboration Services	Core Services
JTF HQ	JLSG	Document Collaboration & Storage	Information Management	Content Management Services	Core Services
JTF HQ	JLSG	VTC	VTC	Video Based Collaboration Services	Core Services
JTF HQ	JLSG	RLP	Situational Awareness	Logistics Services	COI Services
JLSG	JTF HQ	LOGASSESSREP	Reports	Logistics Services	COI Services
JOINT TASK FORCE HEADQUARTERS (JTF HQ) - CONTRACTORS					
BI-DIRECTIONAL					
JTFHQ	CONTRACT ORS	Voice (Insecure)	Voice	Audio-Based Communication Services	Core Services

IER From	IER To	IE Product	User Service Definition Operational Capability	Technical Service Level 2	Technical Service Level 1
JTFHQ	CONTRACT ORS	Informal Message	Informal Messaging	Informal Messaging Services	Core Services
JTFHQ	CONTRACT ORS	Contracting Info	Reports	ERP Services	COI Services
JTFHQ	CONTRACT ORS	Fax	Fax	Fax Services	Core Services
JOINT LOGISTICS SUPPORT GROUP (JLSG) - SEAPORT OF DISEMBARKATION (SPOD)					
JLSG	SPOD	RSOM Plan	Plans	Logistics Services	COI Services
JLSG	SPOD	RLP	Situational Awareness	Logistics Services	COI Services
JLSG	SPOD	RSOM Op Order	Tasking & Orders	Logistics Services	COI Services
SPOD	JLSG	PERSREP	Reports	Logistics Services	COI Services
SPOD	JLSG	MATDEM	Requests & Responses	Logistics Services	COI Services
SPOD	JLSG	MOVSITREP	Plans	Logistics Services	COI Services
BI-DIRECTIONAL					
JLSG	SPOD	Voice (Secure)	Voice	Audio-Based Communication Services	Core Services
JLSG	SPOD	Formal Message	Formal Messaging	Military Messaging Service	Core Enterprise Services
JLSG	SPOD	Informal Message	Informal Messaging	Informal Messaging Services	Core Services
JLSG	SPOD	Document Collaboration & Storage	Information Management	Content Management Services	Core Services

NATO UNCLASSIFIED
DRAFT

ANNEX C TO
MC 0640

IER From	IER To	IE Product	User Service Definition Operational Capability	Technical Service Level 2	Technical Service Level 1
JLSG	SPOD	Instant Message	Instant Messaging	Text-Based Collaboration Services	Core Services
JLSG	SPOD	Office Collaboration (Audio)	Collaboration	Audio-Based Communication Services	Core Services
JLSG	SPOD	Office Collaboration (AV)	Collaboration	Video-Based Communication Services	Core Services
JLSG	SPOD	Office Collaboration (Chat)	Collaboration	Text-Based Collaboration Services	Core Services
JLSG	SPOD	VTC	VTC	Video Based Collaboration Services	Core Services
JOINT LOGISTICS SUPPORT GROUP (JLSG) - AIRPORT OF DISEMBARKATION (APOD)					
JLSG	APOD	RSOM Plan	Plans	Logistics Services	COI Services
JLSG	APOD	RLP	Situational Awareness	Logistics Services	COI Services
JLSG	APOD	RSOM Op Order	Tasking & Orders	Logistics Services	COI Services
APOD	JLSG	PERSREP	Reports	Logistics Services	COI Services
APOD	JLSG	MATDEM	Requests & Responses	Logistics Services	COI Services
APOD	JLSG	MOVSITREP	Plans	Logistics Services	COI Services
BI-DIRECTIONAL					
JLSG	APOD	Voice (Secure)	Voice	Audio-Based Communication Services	Core Services

IER From	IER To	IE Product	User Service Definition Operational Capability	Technical Service Level 2	Technical Service Level 1
JLSG	APOD	Formal Message	Formal Messaging	Military Messaging Service	Core Enterprise Services
JLSG	APOD	Informal Message	Informal Messaging	Informal Messaging Services	Core Services
JLSG	APOD	Instant Message	Instant Messaging	Text-Based Collaboration Services	Core Services
JLSG	APOD	Office Collaboration (Audio)	Collaboration	Audio-Based Communication Services	Core Services
JLSG	APOD	Office Collaboration (AV)	Collaboration	Video-Based Communication Services	Core Services
JLSG	APOD	Office Collaboration (Chat)	Collaboration	Text-Based Collaboration Services	Core Services
JLSG	APOD	VTC	VTC	Video Based Collaboration Services	Core Services
AIRPORT OF DISEMBARKATION (APOD) - SEAPORT OF DISEMBARKATION (SPOD)					
BI-DIRECTIONAL					
APOD	SPOD	Voice (Secure)	Voice	Audio-Based Communication Services	Core Services
APOD	SPOD	Informal Message	Informal Messaging	Informal Messaging Services	Core Services

IER From	IER To	IE Product	User Service Definition Operational Capability	Technical Service Level 2	Technical Service Level 1
APOD	SPOD	Instant Message	Instant Messaging	Text-Based Collaboration Services	Core Services
APOD	SPOD	Office Collaboration (Audio)	Collaboration	Audio-Based Communication Services	Core Services
APOD	SPOD	Office Collaboration (AV)	Collaboration	Video-Based Communication Services	Core Services
APOD	SPOD	Office Collaboration (Chat)	Collaboration	Text-Based Collaboration Services	Core Services
APOD	SPOD	VTC	VTC	Video Based Collaboration Services	Core Services
SEAPORT OF DISEMBARKATION (SPOD) - NATO FORCE INTEGRATION UNIT (NFIU)/HOST NATION (HN)					
NFIU/HN	SPOD	LOGUPDATE	Reports	Logistics Services	COI Services
NFIU/HN	SPOD	MATDEM	Requests & Responses	Logistics Services	COI Services
BI-DIRECTIONAL					
NFIU/HN	SPOD	Voice (Secure)	Voice	Audio-Based Communication Services	Core Services
NFIU/HN	SPOD	Informal Message	Informal Messaging	Informal Messaging Services	Core Services

NATO UNCLASSIFIED
DRAFT

ANNEX C TO
 MC 0640

IER From	IER To	IE Product	User Service Definition Operational Capability	Technical Service Level 2	Technical Service Level 1
NFIU/HN	SPOD	Instant Message	Instant Messaging	Text-Based Collaboration Services	Core Services
AIRPORT OF DISEMBARKATION (APOD) - NATO FORCE INTEGRATION UNIT (NFIU)/HOST NATION (HN)					
NFIU/HN	APOD	LOGUPDATE	Reports	Logistics Services	COI Services
NFIU/HN	APOD	MATDEM	Requests & Responses	Logistics Services	COI Services
BI-DIRECTIONAL					
NFIU/HN	APOD	Voice (Secure)	Voice	Audio-Based Communication Services	Core Services
NFIU/HN	APOD	Informal Message	Informal Messaging	Informal Messaging Services	Core Services
NFIU/HN	APOD	Instant Message	Instant Messaging	Text-Based Collaboration Services	Core Services
JOINT LOGISTICS SUPPORT GROUP (JLSG) - CONTRACTORS					
BI-DIRECTIONAL					
JLSG	CONTRACT ORS	Voice (Insecure)	Voice	Audio-Based Communication Services	Core Services
JLSG	CONTRACT ORS	Informal Message	Informal Messaging	Informal Messaging Services	Core Services
JLSG	CONTRACT ORS	Contracting Info	Reports	ERP Services	COI Services
JLSG	CONTRACT ORS	Fax	Fax	Fax Services	Core Services

IER From	IER To	IE Product	User Service Definition Operational Capability	Technical Service Level 2	Technical Service Level 1
JOINT LOGISTICS SUPPORT GROUP (JLSG) - BRIGADE SUPPORT GROUP (BSG)					
JLSG	BSG	RSOM Plan	Plans	Logistics Services	COI Services
JLSG	BSG	RLP	Situational Awareness	Logistics Services	COI Services
JLSG	BSG	RSOM Op Order	Tasking & Orders	Logistics Services	COI Services
BSG	JLSG	LOGUPDATE	Reports	Logistics Services	COI Services
BSG	JLSG	PERSREP	Reports	Logistics Services	COI Services
BSG	JLSG	MATDEM	Requests & Responses	Logistics Services	COI Services
BSG	JLSG	Convoy Tracks	Live Tracks	Battlespace Information Services	COI Services
BSG	JLSG	ORBAT	Situational Awareness	Situational Awareness Service	COI Services
BI-DIRECTIONAL					
JLSG	BSG	Voice (Secure)	Informal Messaging	Informal Messaging Services	Core Services
JLSG	BSG	Formal Message	Formal Messaging	Military Messaging Service	Core Services
JLSG	BSG	Informal Message	Instant Messaging	Text-Based Collaboration Services	Core Services
JLSG	BSG	Instant Message	Instant Messaging	Text-Based Collaboration Services	Core Services
JLSG	BSG	LOGASSESSREP	Reports	Logistics Services	COI Services

NATO UNCLASSIFIED
DRAFT

ANNEX C TO
 MC 0640

IER From	IER To	IE Product	User Service Definition Operational Capability	Technical Service Level 2	Technical Service Level 1
JLSG	BSG	Movement &Transportation Information (M&T Info)	Situational Awareness	Logistics Services	COI Services
JLSG	BSG	VTC	VTC	Video Based Collaboration Services	Core Services
JOINT LOGISTICS SUPPORT GROUP (JLSG) - NATO FORCE INTEGRATION UNIT (NFIU)/HOST NATION (HN)					
JLSG	NFIU/HN	RSOM Plan	Plans	Logistics Services	COI Services
JLSG	NFIU/HN	RLP	Situational Awareness	Logistics Services	COI Services
JLSG	NFIU/HN	RSOM Op Order	Tasking & Orders	Logistics Services	COI Services
JLSG	NFIU/HN	Document Collaboration & Storage	VTC	Video Based Collaboration Services	Core Services
JLSG	NFIU/HN	PERSREP	Reports	Logistics Services	COI Services
JLSG	NFIU/HN	MOVSITREP	Plans	Logistics Services	COI Services
BI-DIRECTIONAL					
JLSG	NFIU/HN	Voice (Secure)	Voice	Audio-Based Communication Services	Core Services
JLSG	NFIU/HN	Formal Message	Formal Messaging	Military Messaging Service	Core Services
JLSG	NFIU/HN	Informal Message	Informal Messaging	Informal Messaging Services	Core Services

NATO UNCLASSIFIED
DRAFT

ANNEX C TO
 MC 0640

IER From	IER To	IE Product	User Service Definition Operational Capability	Technical Service Level 2	Technical Service Level 1
JLSG	NFIU/HN	Instant Message	Instant Messaging	Text-Based Collaboration Services	Core Services
JLSG	NFIU/HN	Office Collaboration (Audio)	Collaboration	Audio-Based Communication Services	Core Services
JLSG	NFIU/HN	Office Collaboration (AV)	Collaboration	Video-Based Communication Services	Core Services
JLSG	NFIU/HN	Office Collaboration (Chat)	Collaboration	Text-Based Collaboration Services	Core Services
JLSG	NFIU/HN	Document Collaboration & Storage	Information Management	Content Management Services	Core Services
JLSG	NFIU/HN	VTC	VTC	Video Based Collaboration Services	Core Services
JLSG	NFIU/HN	LOGASSESSREP	Reports	Logistics Services	COI Services
NATO FORCE INTEGRATION UNIT (NFIU)/HOST NATION (HN) - CONTRACTORS					
BI-DIRECTIONAL					
NFIU/HN	CONTRACT ORS	Voice (InSecure)	Voice	Audio-Based Communication Services	Core Services
NFIU/HN	CONTRACT ORS	Informal Message	Informal Messaging	Informal Messaging Services	Core Services

IER From	IER To	IE Product	User Service Definition Operational Capability	Technical Service Level 2	Technical Service Level 1
NFIU/HN	CONTRACT ORS	Contracting Info	Reports	ERP Services	COI Services
NFIU/HN	CONTRACT ORS	Fax	Fax	Fax Services	Core Services
NATO FORCE INTEGRATION UNIT (NFIU)/HOST NATION (HN)- BRIGADE SUPPORT GROUP (BSG)					
NFIU/HN	BSG	RLS Info	JISR Imagery and Video Services	Reports	Logistics Services
NFIU/HN	BSG	LOGREP	Reports	Logistics Services	COI Services
BSG	NFIU/HN	RLS Request	Requests & Responses	Logistics Services	COI Services
BSG	NFIU/HN	M&T Info	M&T Info	Situational Awareness	Logistics Services
BSG	NFIU/HN	Supp & Matt Info	Supp & Mat Info	Reports	Logistics Services
BI-DIRECTIONAL					
NFIU/HN	BSG	Voice (InSecure)	Voice	Audio-Based Communication Services	Core Services
NFIU/HN	BSG	Informal Message	Informal Messaging	Informal Messaging Services	Core Services
NFIU/HN	BSG	Instant Message	Instant Messaging	Text-Based Collaboration Services	Core Services
NFIU/HN	BSG	Formal Message	Formal Messaging	Military Messaging Service	Core Services

IER From	IER To	IE Product	User Service Definition Operational Capability	Technical Service Level 2	Technical Service Level 1
BRIGADE SUPPORT GROUP - CONTRACTORS					
BI-DIRECTIONAL					
BSG	CONTRACT ORS	Voice (InSecure)	Voice	Audio-Based Communication Services	Core Services
BSG	CONTRACT ORS	Informal Message	Informal Messaging	Informal Messaging Services	Core Services
BSG	CONTRACT ORS	Contracting Info	Reports	ERP Services	COI Services
BSG	CONTRACT ORS	Fax	Fax	Fax Services	Core Services
MAINTENANCE COMPANY (MC)/EQUIPMENT SUPPORT SERVICES (ES) - BACKLOADING POINT (BP)					
BI-DIRECTIONAL					
MC/ES	BP	Voice (Secure)	Voice	Audio-Based Communication Services	Core Services
MC/ES	BP	Instant Message	Instant Messaging	Text-Based Collaboration Services	Core Services
MC/ES	BP	Movement &Transportation Information (M&T Info)	Situational Awareness	Logistics Services	COI Services
MAINTENANCE COMPANY (MC)/EQUIPMENT SUPPORT SERVICES (ES) - EQUIPMENT COLLECTION & COORDINATION POINT (ECCP)					
MC/ES	ECCP	ES Tasking	Tasking & Orders	Logistics Services	COI Services

NATO UNCLASSIFIED
DRAFT

ANNEX C TO
 MC 0640

IER From	IER To	IE Product	User Service Definition Operational Capability	Technical Service Level 2	Technical Service Level 1
ECCP	MC/ES	LOGREP	Reports	Logistics Services	COI Services
ECCP	MC/ES	MATDEM	Requests & Responses	Logistics Services	COI Services
BI-DIRECTIONAL					
MC/ES	ECCP	Voice (Secure)	Voice	Audio-Based Communication Services	Core Services
MC/ES	ECCP	Instant Message	Instant Messaging	Text-Based Collaboration Services	Core Services
MC/ES	ECCP	Movement & Transportation Information (M&T Info)	Situational Awareness	Logistics Services	COI Services
EQUIPMENT COLLECTION & COORDINATION POINT (ECCP) - BACKLOADING POINT (BP)					
BI-DIRECTIONAL					
ECCP	BP	Voice (Secure)	Voice	Audio-Based Communication Services	Core Services
ECCP	BP	Instant Message	Instant Messaging	Text-Based Collaboration Services	Core Services
ECCP	BP	Movement &Transportation Information (M&T Info)	Situational Awareness	Logistics Services	COI Services

IER From	IER To	IE Product	User Service Definition Operational Capability	Technical Service Level 2	Technical Service Level 1
EQUIPMENT COLLECTION & COORDINATION POINT (ECCP) - FORWARD REPAIR TEAMS (FRT)					
ECCP	FRT	ES Tasking	Tasking & Orders	Logistics Services	COI Services
FRT	ECCP	Movement &Transportation Information (M&T Info)	Situational Awareness	Logistics Services	COI Services
BI-DIRECTIONAL					
ECCP	FRT	Voice (Secure)	Voice	Audio-Based Communication Services	Core Services
ECCP	FRT	Instant Message	Instant Messaging	Text-Based Collaboration Services	Core Services
ECCP	FRT	Movement &Transportation Information (M&T Info)	Situational Awareness	Logistics Services	COI Services
EQUIPMENT COLLECTION & COORDINATION POINT (ECCP) - A2 ECHELON BATTLE GROUP LEVEL (A2 ECH)					
BI-DIRECTIONAL					
ECCP	A2 Ech	Voice (Secure)	Voice	Audio-Based Communication Services	Core Services
ECCP	A2 Ech	Instant Message	Instant Messaging	Text-Based Collaboration Services	Core Services

IER From	IER To	IE Product	User Service Definition Operational Capability	Technical Service Level 2	Technical Service Level 1
ECCP	A2 Ech	Document Collaboration & Storage	Information Management	Content Management Services	Core Services
ECCP	A2 Ech	Movement &Transportation Information (M&T Info)	Situational Awareness	Logistics Services	COI Services
BRIGADE SUPPORT GROUP (BSG) - A2 ECHELON BATTLE GROUP LEVEL (A2 ECH)					
A2 Ech	BSG	LOGREP	Reports	Logistics Services	COI Services
A2 Ech	BSG	PERSREP	Reports	Logistics Services	COI Services
A2 Ech	BSG	Convoy Tracks	Live Tracks	Battlespace Information Services	COI Services
A2 Ech	BSG	MATDEM	Requests & Responses	Logistics Services	COI Services
A2 Ech	BSG	ES Request	Requests & Responses	Logistics Services	COI Services
BI-DIRECTIONAL					
BSG	A2 Ech	Voice (Secure)	Voice	Audio-Based Communication Services	Core Services
BSG	A2 Ech	Instant Message	Instant Messaging	Text-Based Collaboration Services	Core Services
BSG	A2 Ech	Informal Message	Informal Messaging	Informal Messaging Services	Core Services

NATO UNCLASSIFIED
DRAFT

ANNEX C TO
 MC 0640

IER From	IER To	IE Product	User Service Definition Operational Capability	Technical Service Level 2	Technical Service Level 1
BSG	A2 Ech	Movement &Transportation Information (M&T Info)	Situational Awareness	Logistics Services	COI Services
BSG	A2 Ech	LOGASSESSREP	Reports	Logistics Services	COI Services
A2 ECHELON BATTLE GROUP LEVEL (A2 Ech) - A1 ECHELON COMPANY LEVEL (A1 Ech)					
A1 Ech	A2 Ech	LOGREP	Reports	Logistics Services	COI Services
A1 Ech	A2 Ech	PERSREP	Reports	Logistics Services	COI Services
A1 Ech	A2 Ech	Convoy Tracks	Live Tracks	Battlespace Information Services	COI Services
A1 Ech	A2 Ech	MATDEM	Requests & Responses	Logistics Services	COI Services
A1 Ech	A2 Ech	ES Request	Requests & Responses	Logistics Services	COI Services
BI-DIRECTIONAL					
A2 Ech	A1 Ech	Voice (Secure)	Voice	Audio-Based Communication Services	Core Services
A2 Ech	A1 Ech	Instant Message	Instant Messaging	Text-Based Collaboration Services	Core Services
A2 Ech	A1 Ech	Movement &Transportation Information (M&T Info)	Situational Awareness	Logistics Services	COI Services
A2 Ech	A1 Ech	LOGASSESSREP	Reports	Logistics Services	COI Services

IER From	IER To	IE Product	User Service Definition Operational Capability	Technical Service Level 2	Technical Service Level 1
A1 ECHELON COMPANY LEVEL (A1 Ech) - FORWARD REPAIR TEAM (FRT)					
BI-DIRECTIONAL					
A1 Ech	FRT	Voice (Secure)	Voice	Audio-Based Communication Services	Core Services
A1 Ech	FRT	Instant Message	Instant Messaging	Text-Based Collaboration Services	Core Services
A1 Ech	FRT	Movement &Transportation Information (M&T Info)	Situational Awareness	Logistics Services	COI Services
A1 ECHELON COMPANY LEVEL (A1 Ech) - FRONTLINE TROOPS (FLT)					
FLT	A1 Ech	LOGREP	Reports	Logistics Services	COI Services
FLT	A1 Ech	PERSREP	Reports	Logistics Services	COI Services
FLT	A1 Ech	Convoy Tracks	Live Tracks	Battlespace Information Services	COI Services
FLT	A1 Ech	MATDEM	Requests & Responses	Logistics Services	COI Services
FLT	A1 Ech	ES Request	Requests & Responses	Logistics Services	COI Services
BI-DIRECTIONAL					
A1 Ech	FLT	Voice (Secure)	Voice	Audio-Based Communication Services	Core Services
A1 Ech	FLT	Instant Message	Instant Messaging	Text-Based Collaboration Services	COI Services

NATO UNCLASSIFIED
DRAFT

ANNEX C TO
 MC 0640

IER From	IER To	IE Product	User Service Definition Operational Capability	Technical Service Level 2	Technical Service Level 1
A1 Ech	FLT	LOGASSESSREP	Reports	Logistics Services	COI Services
NATIONAL SUPPORT ELEMENT (NSE) - NATIONAL SUPPORT ELEMENT (NSE)					
NSE	NSE	National Responsibility			
NATIONAL SUPPORT ELEMENT (NSE) - TROOP CONTRIBUTING NATIONS FORWARD SUPPORT GROUP (TCN FSG)					
NSE	TCN FSG	National Responsibility			

Table C-6: Logistics Support in a VJTF(L) Scenario Product Dissemination and Consumption

MJO+ LOGISTICS SUPPORT IER

20. Specific C2 and H2H information product exchange to enable the effective Logistics Support to be provided in the land environment during a MJO+ scenario is depicted in Figure C-8. The unidirectional red and green arrows represent products either consumed or disseminated from Logistics entities within the land environment. The bi-directional black arrows represent products that are both disseminated and consumed by Logistics entities deployed in support of a Land based deployment:

NATO UNCLASSIFIED
DRAFT

ANNEX C TO
 MC 0640

21. As introduced in Figure C-8, the products depicted in the Table C-7 details the unidirectional and bi-directional products relating to the Logistics support process within a land environment under a MJO+ scenario. The column 'IER From' and 'IER To' details the C2 entities which the information products are exchanged with; the third column lists the product that is exchanged. Column 4 lists the operational capability that the product supports and columns 5 - 6 map the product to the service type as detailed in the C3 Taxonomy nomenclature:

IER From	IER To	IE Product	User Service Definition Operational Capability	Technical Service Level 2	Technical Service Level 1
JOINT TASK FORCE HEADQUARTERS (JTF HQ) - JOINT LOGISTICS SUPPORT GROUP (JLSG)					
JLSG	JTF HQ	FRAGO (to RSOM)	Tasking & Orders	Joint Services	COI Services
JLSG	JTF HQ	Convoy Tracks	Live Tracks	Battlespace Information Services	COI Services
JLSG	JTF HQ	ORBAT	Situational Awareness	Situational Awareness Service	COI Services
JLSG	JTF HQ	PERSREP	Reports	Logistics Services	COI Services
BI-DIRECTIONAL					
JTF HQ	JLSG	Voice (Secure)	Voice	Audio-Based Communication Services	Core Services
JTF HQ	JLSG	Formal Message	Formal Messaging	Military Messaging Service	Core Services
JTF HQ	JLSG	Informal Message	Informal Messaging	Informal Messaging Services	Core Services

IER From	IER To	IE Product	User Service Definition Operational Capability	Technical Service Level 2	Technical Service Level 1
JTF HQ	JLSG	Instant Message	Instant Messaging	Text-Based Collaboration Services	Core Services
JTF HQ	JLSG	Office Collaboration (Audio)	Collaboration	Audio-Based Communication Services	Core Services
JTF HQ	JLSG	Office Collaboration (AV)	Collaboration	Video-Based Communication Services	Core Services
JTF HQ	JLSG	Office Collaboration (Chat)	Collaboration	Text-Based Collaboration Services	Core Services
JTF HQ	JLSG	Document Collaboration & Storage	VTC	Video Based Collaboration Services	Core Services
JTF HQ	JLSG	VTC	VTC	Video Based Collaboration Services	Core Services
JTF HQ	JLSG	RLP	Situational Awareness	Logistics Services	COI Services
JLSG	JTF HQ	LOGASSESSREP	Reports	Logistics Services	COI Services
JOINT TASK FORCE HEADQUARTERS (JTF HQ) - LAND COMMAND (LANDCOM)					
JTF HQ	LANDCOM	RLP	Situational Awareness	Logistics Services	COI Services

IER From	IER To	IE Product	User Service Definition Operational Capability	Technical Service Level 2	Technical Service Level 1
BI-DIRECTIONAL					
JTF HQ	LANDCOM	Voice (Secure)	Voice	Audio-Based Communication Services	Core Services
JTF HQ	LANDCOM	Formal Message	Formal Messaging	Military Messaging Service	Core Services
JTF HQ	LANDCOM	Informal Message	Informal Messaging	Informal Messaging Services	Core Services
JTF HQ	LANDCOM	Instant Message	Instant Messaging	Text-Based Collaboration Services	Core Services
JTF HQ	LANDCOM	Office Collaboration (Audio)	Collaboration	Audio-Based Communication Services	Core Services
JTF HQ	LANDCOM	Office Collaboration (AV)	Collaboration	Video-Based Communication Services	Core Services
JTF HQ	LANDCOM	Office Collaboration (Chat)	Collaboration	Text-Based Collaboration Services	Core Services
JTF HQ	LANDCOM	Document Collaboration & Storage	Content Management Services	Information Management	COI Services
JTF HQ	LANDCOM	VTC	VTC	Video Based Collaboration Services	Core Services

IER From	IER To	IE Product	User Service Definition Operational Capability	Technical Service Level 2	Technical Service Level 1
JOINT TASK FORCE HEADQUARTERS (JTF HQ) - CONTRACTORS					
BI-DIRECTIONAL					
JTFHQ	CONTRACT ORS	Voice (Insecure)	Voice	Audio-Based Communication Services	Core Services
JTFHQ	CONTRACT ORS	Informal Message	Informal Messaging	Informal Messaging Services	Core Services
JTFHQ	CONTRACT ORS	Contracting Info	Reports	ERP Services	COI Services
JTFHQ	CONTRACT ORS	Fax	Fax	Fax Services	Core Services
JTFHQ	CONTRACT ORS	Document Collaboration & Storage	VTC	Video Based Collaboration Services	Core Services
JOINT LOGISTICS SUPPORT GROUP (JLSG) - SEAPORT OF DISEMBARKATION (SPOD)					
JLSG	SPOD	RSOM Plan	Plans	Logistics Services	COI Services
JLSG	SPOD	RLP	Situational Awareness	Logistics Services	COI Services
JLSG	SPOD	RSOM Op Order	Tasking & Orders	Logistics Services	COI Services
SPOD	JLSG	PERSREP	Reports	Logistics Services	COI Services
SPOD	JLSG	MATDEM	Requests & Responses	Logistics Services	COI Services
SPOD	JLSG	MOVSITREP	Plans	Logistics Services	COI Services
BI-DIRECTIONAL					
JLSG	SPOD	Voice (Secure)	Voice	Audio-Based Communication Services	Core Services

IER From	IER To	IE Product	User Service Definition Operational Capability	Technical Service Level 2	Technical Service Level 1
JLSG	SPOD	Formal Message	Formal Messaging	Military Messaging Service	Core Enterprise Services
JLSG	SPOD	Informal Message	Informal Messaging	Informal Messaging Services	Core Services
JLSG	SPOD	Instant Message	Instant Messaging	Text-Based Collaboration Services	Core Services
JLSG	SPOD	Office Collaboration (Audio)	Collaboration	Audio-Based Communication Services	Core Services
JLSG	SPOD	Office Collaboration (AV)	Collaboration	Video-Based Communication Services	Core Services
JLSG	SPOD	Office Collaboration (Chat)	Collaboration	Text-Based Collaboration Services	Core Services
JLSG	SPOD	VTC	VTC	Video Based Collaboration Services	Core Services
JOINT LOGISTICS SUPPORT GROUP (JLSG) - AIRPORT OF DISEMBARKATION (APOD)					
JLSG	APOD	RSOM Plan	Plans	Logistics Services	COI Services
JLSG	APOD	RLP	Situational Awareness	Logistics Services	COI Services
JLSG	APOD	RSOM Op Order	Tasking & Orders	Logistics Services	COI Services
APOD	JLSG	PERSREP	Reports	Logistics Services	COI Services
APOD	JLSG	MATDEM	Requests & Responses	Logistics Services	COI Services
APOD	JLSG	MOVSITREP	Plans	Logistics Services	COI Services

NATO UNCLASSIFIED
DRAFT

ANNEX C TO
 MC 0640

IER From	IER To	IE Product	User Service Definition Operational Capability	Technical Service Level 2	Technical Service Level 1
BI-DIRECTIONAL					
JLSG	APOD	Voice (Secure)	Voice	Audio-Based Communication Services	Core Services
JLSG	APOD	Formal Message	Formal Messaging	Military Messaging Service	Core Enterprise Services
JLSG	APOD	Informal Message	Informal Messaging	Informal Messaging Services	Core Services
JLSG	APOD	Instant Message	Instant Messaging	Text-Based Collaboration Services	Core Services
JLSG	APOD	Office Collaboration (Audio)	Collaboration	Audio-Based Communication Services	Core Services
JLSG	APOD	Office Collaboration (AV)	Collaboration	Video-Based Communication Services	Core Services
JLSG	APOD	Office Collaboration (Chat)	Collaboration	Text-Based Collaboration Services	Core Services
JLSG	APOD	VTC	VTC	Video Based Collaboration Services	Core Services

IER From	IER To	IE Product	User Service Definition Operational Capability	Technical Service Level 2	Technical Service Level 1
AIRPORT OF DISEMBARKATION (APOD) - SEAPORT OF DISEMBARKATION (SPOD)					
BI-DIRECTIONAL					
APOD	SPOD	Voice (Secure)	Voice	Audio-Based Communication Services	Core Services
APOD	SPOD	Informal Message	Informal Messaging	Informal Messaging Services	Core Services
APOD	SPOD	Instant Message	Instant Messaging	Text-Based Collaboration Services	Core Services
APOD	SPOD	Office Collaboration (Audio)	Collaboration	Audio-Based Communication Services	Core Services
APOD	SPOD	Office Collaboration (AV)	Collaboration	Video-Based Communication Services	Core Services
APOD	SPOD	Office Collaboration (Chat)	Collaboration	Text-Based Collaboration Services	Core Services
APOD	SPOD	VTC	VTC	Video Based Collaboration Services	Core Services
SEAPORT OF DISEMBARKATION (SPOD) - NATO FORCE INTEGRATION UNIT (NFIU)/HOST NATION (HN)					
NFIU/HN	SPOD	LOGUPDATE	Reports	Logistics Services	COI Services
NFIU/HN	SPOD	MATDEM	Requests & Responses	Logistics Services	COI Services

NATO UNCLASSIFIED
DRAFT

ANNEX C TO
 MC 0640

IER From	IER To	IE Product	User Service Definition Operational Capability	Technical Service Level 2	Technical Service Level 1
BI-DIRECTIONAL					
NFIU/HN	SPOD	Voice (Secure)	Voice	Audio-Based Communication Services	Core Services
NFIU/HN	SPOD	Informal Message	Informal Messaging	Informal Messaging Services	Core Services
NFIU/HN	SPOD	Instant Message	Instant Messaging	Text-Based Collaboration Services	Core Services
AIRPORT OF DISEMBARKATION (APOD) - NATO FORCE INTEGRATION UNIT (NFIU)/HOST NATION (HN)					
NFIU/HN	APOD	LOGUPDATE	Reports	Logistics Services	COI Services
NFIU/HN	APOD	MATDEM	Requests & Responses	Logistics Services	COI Services
BI-DIRECTIONAL					
NFIU/HN	APOD	Voice (Secure)	Voice	Audio-Based Communication Services	Core Services
NFIU/HN	APOD	Informal Message	Informal Messaging	Informal Messaging Services	Core Services
NFIU/HN	APOD	Instant Message	Instant Messaging	Text-Based Collaboration Services	Core Services
JOINT LOGISTICS SUPPORT GROUP (JLSG) - CONTRACTORS					
BI-DIRECTIONAL					
JLSG	CONTRACT ORS	Voice (Insecure)	Voice	Audio-Based Communication Services	Core Services

IER From	IER To	IE Product	User Service Definition Operational Capability	Technical Service Level 2	Technical Service Level 1
JLSG	CONTRACT ORS	Informal Message	Informal Messaging	Informal Messaging Services	Core Services
JLSG	CONTRACT ORS	Contracting Info	Reports	ERP Services	COI Services
JLSG	CONTRACT ORS	Fax	Fax	Fax Services	Core Services
JOINT LOGISTICS SUPPORT GROUP (JLSG) - LAND COMMAND (LANDCOM)					
JLSG	LANDCOM	RSOM Plan	Plans	Logistics Services	COI Services
JLSG	LANDCOM	RLP	Situational Awareness	Logistics Services	COI Services
JLSG	LANDCOM	RSOM Op Order	Tasking & Orders	Logistics Services	COI Services
LANDCOM	JLSG	LOGUPDATE	Reports	Logistics Services	COI Services
LANDCOM	JLSG	PERSREP	Reports	Logistics Services	COI Services
LANDCOM	JLSG	MATDEM	Requests & Responses	Logistics Services	COI Services
LANDCOM	JLSG	Convoy Tracks	Live Tracks	Battlespace Information Services	COI Services
LANDCOM	JLSG	ORBAT	Situational Awareness	Situational Awareness Service	COI Services
LANDCOM	JLSG	Document Collaboration & Storage	VTC	Video Based Collaboration Services	Core Services
BI-DIRECTIONAL					
JLSG	LANDCOM	Voice (Secure)	Informal Messaging	Informal Messaging Services	Core Services
JLSG	LANDCOM	Formal Message	Formal Messaging	Military Messaging Service	Core Services

IER From	IER To	IE Product	User Service Definition Operational Capability	Technical Service Level 2	Technical Service Level 1
JLSG	LANDCOM	Informal Message	Instant Messaging	Text-Based Collaboration Services	Core Services
JLSG	LANDCOM	Instant Message	Instant Messaging	Text-Based Collaboration Services	Core Services
JLSG	LANDCOM	LOGASSESSREP	Reports	Logistics Services	COI Services
JLSG	LANDCOM	Movement & Transportation Information (M&T Info)	Situational Awareness	Logistics Services	COI Services
JLSG	LANDCOM	Office Collaboration (Audio)	Collaboration	Audio-Based Communication Services	Core Services
JLSG	LANDCOM	Office Collaboration (AV)	Collaboration	Video-Based Communication Services	Core Services
JLSG	LANDCOM	Office Collaboration (Chat)	Collaboration	Text-Based Collaboration Services	Core Services
JLSG	LANDCOM	Document Collaboration & Storage	Content Management Services	Information Management	COI Services
JLSG	LANDCOM	VTC	VTC	Video Based Collaboration Services	Core Services

IER From	IER To	IE Product	User Service Definition Operational Capability	Technical Service Level 2	Technical Service Level 1
JOINT LOGISTICS SUPPORT GROUP (JLSG) - CORPS REAR SUPPORT GROUP (CRSG)					
JLSG	CRSG	MATDEM	Requests & Responses	Logistics Services	COI Services
BI-DIRECTIONAL					
JLSG	CRSG	Voice (Secure)	Informal Messaging	Informal Messaging Services	Core Services
JLSG	CRSG	Formal Message	Formal Messaging	Military Messaging Service	Core Services
JLSG	CRSG	Informal Message	Instant Messaging	Text-Based Collaboration Services	Core Services
JLSG	CRSG	Instant Message	Instant Messaging	Text-Based Collaboration Services	Core Services
JLSG	CRSG	VTC	VTC	Video Based Collaboration Services	Core Services
LAND COMMAND (LANDCOM) - CONTRACTORS					
BI-DIRECTIONAL					
LANDCOM	CONTRACT ORS	Voice (InSecure)	Voice	Audio-Based Communication Services	Core Services
LANDCOM	CONTRACT ORS	Informal Message	Informal Messaging	Informal Messaging Services	Core Services
LANDCOM	CONTRACT ORS	Contracting Info	Reports	ERP Services	COI Services

IER From	IER To	IE Product	User Service Definition Operational Capability	Technical Service Level 2	Technical Service Level 1
LANDCOM	CONTRACT ORS	Fax	Fax	Fax Services	Core Services
LAND COMMAND (LANDCOM) - NATO FORCE INTEGRATION UNIT (NFIU)					
LANDCOM	NFIU	RLS Request	Requests & Responses	Logistics Services	COI Services
LANDCOM	NFIU	M&T Info	Situational Awareness	Logistics Services	COI Services
LANDCOM	NFIU	Supp & Mat Info	Reports	Logistics Services	COI Services
NFIU	LANDCOM	RLS Info	Reports	Logistics Services	COI Services
NFIU	LANDCOM	LOGREP	Reports	Logistics Services	COI Services
BI-DIRECTIONAL					
LANDCOM	NFIU	Voice (Secure)	Informal Messaging	Informal Messaging Services	Core Services
LANDCOM	NFIU	Formal Message	Formal Messaging	Military Messaging Service	Core Services
LANDCOM	NFIU	Informal Message	Instant Messaging	Text-Based Collaboration Services	Core Services
LANDCOM	NFIU	Instant Message	Instant Messaging	Text-Based Collaboration Services	Core Services
LANDCOM	NFIU	LOGASSESSREP	Reports	Logistics Services	COI Services
LANDCOM	NFIU	VTC	VTC	Video Based Collaboration Services	Core Services
LAND COMMAND (LANDCOM) - CORPS REAR SUPPORT GROUP (CRSG)					
LANDCOM	CRSG	RLP	Situational Awareness	Logistics Services	COI Services
CRSG	LANDCOM	LOGREP	Reports	Logistics Services	COI Services

NATO UNCLASSIFIED
DRAFT

ANNEX C TO
 MC 0640

IER From	IER To	IE Product	User Service Definition Operational Capability	Technical Service Level 2	Technical Service Level 1
CRSG	LANDCOM	PERSREP	Reports	Logistics Services	COI Services
CRSG	LANDCOM	Convoy Tracks	Live Tracks	Battlespace Information Services	COI Services
BI-DIRECTIONAL					
LANDCOM	CRSG	Voice (Secure)	Voice	Audio-Based Communication Services	Core Services
LANDCOM	CRSG	Formal Message	Formal Messaging	Military Messaging Service	Core Services
LANDCOM	CRSG	Informal Message	Informal Messaging	Informal Messaging Services	Core Services
LANDCOM	CRSG	Instant Message	Instant Messaging	Text-Based Collaboration Services	Core Services
LANDCOM	CRSG	Office Collaboration (Audio)	Collaboration	Audio-Based Communication Services	Core Services
LANDCOM	CRSG	Office Collaboration (AV)	Collaboration	Video-Based Communication Services	Core Services
LANDCOM	CRSG	Office Collaboration (Chat)	Collaboration	Text-Based Collaboration Services	Core Services

NATO UNCLASSIFIED
DRAFT

ANNEX C TO
 MC 0640

IER From	IER To	IE Product	User Service Definition Operational Capability	Technical Service Level 2	Technical Service Level 1
LANDCOM	CRSG	Movement &Transportation Information (M&T Info)	Situational Awareness	Logistics Services	COI Services
LANDCOM	CRSG	LOGASSESSREP	Reports	Logistics Services	COI Services
LANDCOM	CRSG	VTC	VTC	Video Based Collaboration Services	Core Services
JOINT LOGISTICS SUPPORT GROUP (JLSG) - NATO FORCE INTEGRATION UNIT (NFIU)/HOST NATION (HN)					
JLSG	NFIU/HN	RSOM Plan	Plans	Logistics Services	COI Services
JLSG	NFIU/HN	RLP	Situational Awareness	Logistics Services	COI Services
JLSG	NFIU/HN	RSOM Op Order	Tasking & Orders	Logistics Services	COI Services
JLSG	NFIU/HN	PERSREP	Reports	Logistics Services	COI Services
JLSG	NFIU/HN	MOVSITREP	Plans	Logistics Services	COI Services
BI-DIRECTIONAL					
JLSG	NFIU/HN	Voice (Secure)	Voice	Audio-Based Communication Services	Core Services
JLSG	NFIU/HN	Formal Message	Formal Messaging	Military Messaging Service	Core Services
JLSG	NFIU/HN	Informal Message	Informal Messaging	Informal Messaging Services	Core Services
JLSG	NFIU/HN	Instant Message	Instant Messaging	Text-Based Collaboration Services	Core Services

NATO UNCLASSIFIED
DRAFT

ANNEX C TO
 MC 0640

IER From	IER To	IE Product	User Service Definition Operational Capability	Technical Service Level 2	Technical Service Level 1
JLSG	NFIU/HN	Office Collaboration (Audio)	Collaboration	Audio-Based Communication Services	Core Services
JLSG	NFIU/HN	Office Collaboration (AV)	Collaboration	Video-Based Communication Services	Core Services
JLSG	NFIU/HN	Document Collaboration & Storage	VTC	Video Based Collaboration Services	Core Services
JLSG	NFIU/HN	Office Collaboration (Chat)	Collaboration	Text-Based Collaboration Services	Core Services
JLSG	NFIU/HN	LOGASSESSREP	Reports	Logistics Services	COI Services
JLSG	NFIU/HN	VTC	VTC	Video Based Collaboration Services	Core Services
NATO FORCE INTEGRATION UNIT (NFIU) - CONTRACTORS					
BI-DIRECTIONAL					
NFIU	CONTRACT ORS	Voice (InSecure)	Voice	Audio-Based Communication Services	Core Services
NFIU	CONTRACT ORS	Informal Message	Informal Messaging	Informal Messaging Services	Core Services
NFIU	CONTRACT ORS	Contracting Info	Reports	ERP Services	COI Services

IER From	IER To	IE Product	User Service Definition Operational Capability	Technical Service Level 2	Technical Service Level 1
NFIU	CONTRACT ORS	Fax	Fax	Fax Services	Core Services
CORPS REAR SUPPORT GROUP (CRSG) - CONTRACTORS					
BI-DIRECTIONAL					
CRSG	CONTRACT ORS	Voice (InSecure)	Voice	Audio-Based Communication Services	Core Services
CRSG	CONTRACT ORS	Informal Message	Informal Messaging	Informal Messaging Services	Core Services
CRSG	CONTRACT ORS	Contracting Info	Reports	ERP Services	COI Services
CRSG	CONTRACT ORS	Fax	Fax	Fax Services	Core Services
DIVISIONAL SUPPORT GROUP (DSG) - CONTRACTORS					
BI-DIRECTIONAL					
DSG	CONTRACT ORS	Voice (InSecure)	Voice	Audio-Based Communication Services	Core Services
DSG	CONTRACT ORS	Informal Message	Informal Messaging	Informal Messaging Services	Core Services
DSG	CONTRACT ORS	Contracting Info	Reports	ERP Services	COI Services
DSG	CONTRACT ORS	Fax	Fax	Fax Services	Core Services
CORPS REAR SUPPORT GROUP (CRSG) - DIVISIONAL SUPPORT GROUP (DSG)					
DSG	CRSG	LOGREP	Reports	Logistics Services	COI Services