

**SRS** (PRTTDCIS-4579)

~~SRS-685~~ AN and BCC Nodes CAS dimensioning shall not include the ROBO license server functionality. Should PRT decide to deploy such servers in those Nodes, the Compute and Storage capacity required for those additional VMs will be taken from the provision for growth included in their original CAS dimensioning.

**SRS** (PRTTDCIS-4580)

~~SRS-686~~ If AN and BCC Nodes CAS dimensioning provision for growth is not sufficient to cover the ROBO license server role, the Contractor shall increase the provision for growth, beyond the minimum values specified in this SRS, up to the minimum Compute and Storage capacity required for the additional VMs.

**5.4.3.3 HDS subsystem**

**NOTE** (PRTTDCIS-3087)

~~467~~ The following picture illustrates the HDS in context.

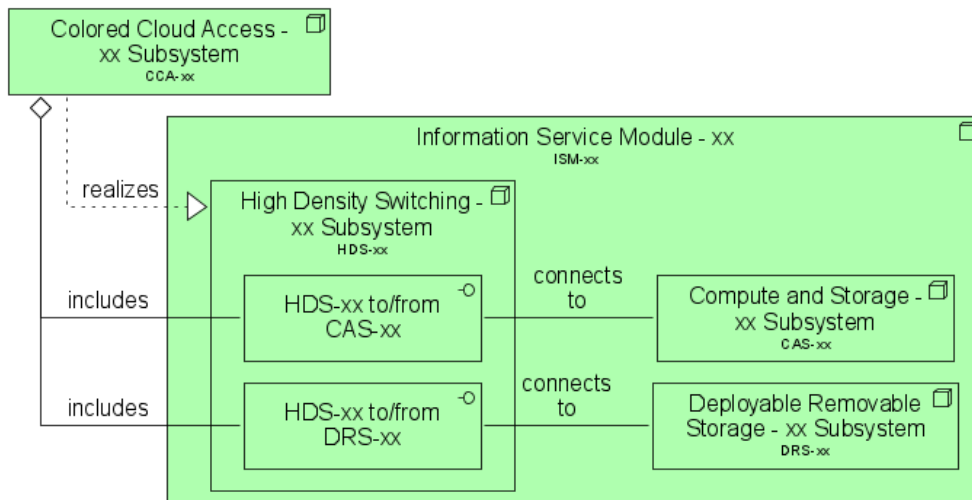

Figure 70 - HDS in context

**SRS** (PRTTDCIS-1729)

~~SRS-687~~ Each HDS subsystem shall, as a minimum, implement interfaces to other subsystems within the ISM as well as to external elements, as per the table below. The need for additional interfaces, or interfaces different from those listed below, as well as their specification, shall be design-driven and shall be justified, based on component selection and functionality sought.

Interface Name	Qty.	Interface Type	Interface Speed	Remarks
HDS-xx to/from CAS-xx	P	Eth-FO-SR	Minimum 10Gbps per server	P is Design Driven
HDS-xx to/from DRS-xx	U	Design Driven	Minimum 10Gbps	U is Design Driven

Table 35 - ISM HDS Interfaces

**SRS** (PRTTDCIS-1732)

~~SRS-688~~ All external ISM interfaces shall be implemented as general purpose, where the configuration, function, activation, monitoring and tearing down of these interfaces shall occur through the Infrastructure Management Toolsuite part of the LMM.

**SRS** (PRTTDCIS-1733)

~~SRS-689~~ The external ISM interfaces "Management" and the interface "DRS" shall be dedicated and accessible all time, independently of the ISM configuration state.

**SRS** (PRTTDCIS-1734)

~~SRS-690~~ It shall be possible to identify physical Interfaces (once configured) using removable and reusable tags.

**SRS** (PRTTDCIS-1736)

~~SRS-691~~ The hardware realizing the HDS shall be sized to allow all ISM interfaces to be operated at near to line rate, all interfaces at the same time and full-duplex, without introducing significant latency, nor jitter.

**SRS** (PRTTDCIS-4105)

~~SRS-692~~ The HDS function of the ISM shall be realized by the Core switching function of the CCA in the CNM.

**5.4.3.4 DRS subsystem**

**SRS** (PRTTDCIS-1737)

~~SRS-693~~ The Deployable Removable Storage (DRS) subsystem shall include the deployable backup storage to support the realization of the Backup and Restore function.

**SRS** (PRTTDCIS-1738)

~~SRS-694~~ The Contractor shall dimension the DRS subsystem in such a way that its composing Elements shall be identical for all nodes, only the installed total storage shall be adapted to the service specificities of each Node.

**SRS** (PRTTDCIS-4204)

~~SRS-695~~ Each Node specific DRS storage shall include a reserve of 20% beyond the dimensioned required capacity.

**SRS** (PRTTDCIS-1739)

~~SRS-696~~ The DRS subsystem shall be implemented using solid-state storage only.

**SRS** (PRTTDCIS-1741)

~~SRS-697~~ The DRS shall implement the interfaces as per Annex I of the DCIS CA and Annex J of the DCIS CA, logically aggregated to minimize the amount of physical connections with the ISM.

**SRS** (PRTTDCIS-1742)

~~SRS-698~~ The DRS subsystem shall be implemented with one physical instance per ISM per security domain.

**SRS** (PRTTDCIS-1740)

~~SRS-699~~ When the ISM is being operated, the DRS subsystem shall be integrated in the shelter racks.

**SRS** (PRTTDCIS-4208)

~~SRS-700~~ The DRS subsystem shall be readily detachable from the shelter rack and fit in a HANDCARRY transport case.

**SRS** (PRTTDCIS-4209)

~~SRS-701~~ The DRS subsystem transport case shall be stored inside the Shelter.

#### 5.4.4 Implementation Constraints

**SRS** (PRTTDCIS-1762)

~~SRS-702~~ The storage function shall support and integrate with the backup/recovery function implemented by the Distributed Resource Scheduler with Deployable Removable Storage.

**SRS** (PRTTDCIS-1764)

~~SRS-703~~ Licensing, where applicable, shall be implemented according to the licensing model of the selected vendor for each CPU core, each physical server and each ISM as specified herein.

**SRS** (PRTTDCIS-1767)

~~SRS-704~~ It shall be possible to connect additional servers, external to the CAS, to the HDS system of the ISM, as PFE (e.g. SPARC servers).

**SRS** (PRTTDCIS-1678)

~~SRS-705~~ The hardware of ISM-xS, ISM-xR and ISM-xU shall be physically built the same, such that these modules are interchangeable.

**SRS** (PRTTDCIS-2866)

~~SRS-706~~ Hard Disk Drives devices shall be removable from the servers of the ISM, for storage and transport.

**SRS** (PRTTDCIS-2867)

~~SRS-707~~ Foam-padded SMALL transport cases able to carry Hard Disk Drives shall be provided for that purpose.

**SRS** (PRTTDCIS-2997)

~~SRS-708~~ xR and xU HDD shall be stored in the same Transport Case.

**SRS** (PRTTDCIS-2998)

~~SRS-709~~ xS HDD shall be stored in a dedicated Transport Case.

## 5.5 Information Services Module Lite

### 5.5.1 General

**NOTE** (PRTTDCIS-2859)

~~[468]~~ The Information Service Module (ISM) lite is a variant of the ISM which shares the same description, functionalities and characteristics.

**SRS** (PRTTDCIS-2860)

~~SRS-710~~ The ISM lite shall comply with all ISM specifications unless specifically specified otherwise.

**SRS** (PRTTDCIS-2825)

~~SRS-711~~ The design of the ISM lite shall adhere to the architecture presented in following figure.

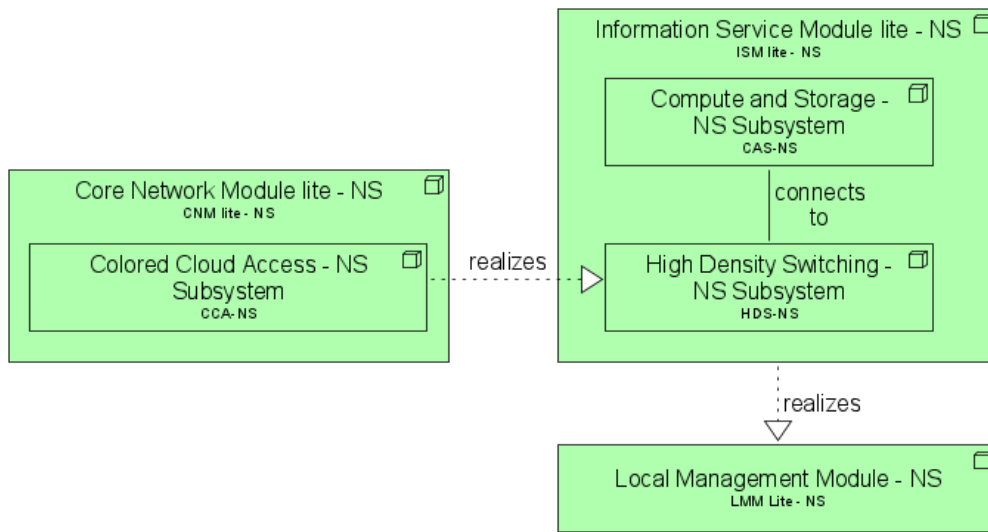

Figure 71 - ISM lite architecture

## 5.5.2 Functional Requirements

**SRS** (PRTTDCIS-2806)

~~SRS-712~~ The ISM lite shall implement the Compute And Storage (CAS) function.

**SRS** (PRTTDCIS-2830)

~~SRS-713~~ The ISM lite shall implement the High Density Switching (HDS) function.

## 5.5.3 Technical Requirements

### 5.5.3.1 CAS subsystem

**SRS** (PRTTDCIS-2864)

~~SRS-714~~ The CAS subsystem in the ISM lite shall implement the functions listed under the CAS function in the ISM.

**SRS** (PRTTDCIS-2865)

~~SRS-715~~ The CAS subsystem in the ISM lite shall meet the same technical requirements formulated for the Single Server CAS subsystem variant of the ISM.

### 5.5.3.2 HDS subsystem

**SRS** (PRTTDCIS-2862)

~~SRS-716~~ The HDS subsystem in the ISM lite shall implement the functions listed under the HDS function in the ISM.

**SRS** (PRTTDCIS-2863)

~~SRS-717~~ The HDS subsystem in the ISM lite shall meet the same technical requirements formulated for the HDS subsystem of the ISM.

**SRS** (PRTTDCIS-2851)

~~SRS-718~~ The HDS subsystem of the ISM lite shall implement the interfaces as specified in table below.

Interface Name	Qty.	Interface Type	Interface Speed	Remarks
HDS-xx to/from CAS-xx	P	Eth-FO-SR	Minimum 2Gbps per server	P is Design Driven

Table 36 - ISM lite HDS Interfaces

**SRS** (PRTTDCIS-4106)

~~SRS-719~~ The HDS function of the ISM Lite shall be realized by the Core switching function of the CCA in the CNM Lite.

### 5.5.4 Implementation Constraints

**SRS** (PRTTDCIS-2819)

~~SRS-720~~ Hard Disk Drives devices shall be removable from the servers of the ISM lite, for storage and transport.

**SRS** (PRTTDCIS-2822)

~~SRS-721~~ Foam-padded transport cases able to carry Hard Disk Drives shall be provided for that purpose.

## 5.6 User Access Module

### 5.6.1 General

**NOTE** (PRTTDCIS-4212)

~~[169]~~ This section describes the User Access Module (UAM) to be implemented in PRT TDCIS.

**NOTE** (PRTTDCIS-2670)

[170] The User Access Module (UAM) is an Architectural Building Block (ABB) which enables User Access Connectivity as illustrated on following picture.

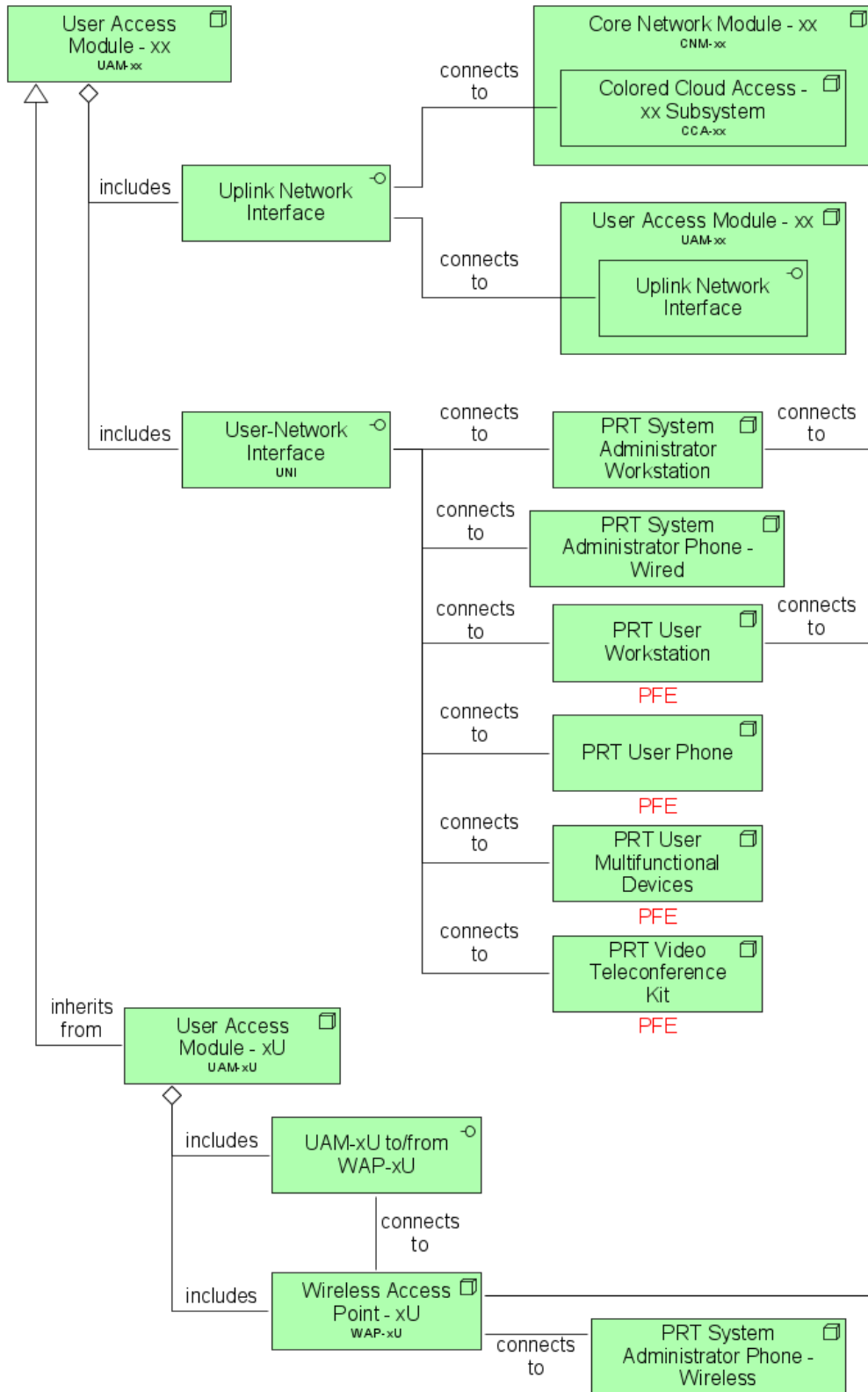

Figure 72 - UAM in context

**NOTE** (PRTTDCIS-2671)

[174] UAM exists in 3 variants:

- 1) **Small:** This variant is realized through the sole usage of network ports available on components of the CCA Subsystem of the CNM;
- 2) **Medium:** This variant is realized through the sole usage of Access Breakout Boxes (BoB);
- 3) **Large:** This variant is realized through the combination of Distribution BoBs and Access BoBs.

**SRS** (PRTTDCIS-2672)

~~SRS-722~~ This project shall only implement Small and Medium variants of UAM.

**SRS** (PRTTDCIS-2673)

~~SRS-723~~ The Small UAM shall adhere to the implementation concept illustrated on following picture.

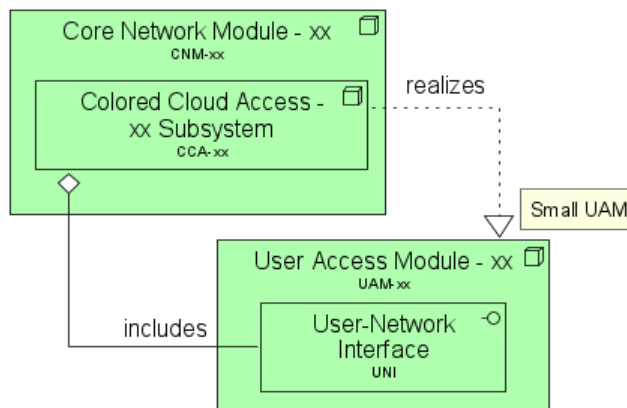

Figure 73 - Small UAM implementation concept



**SRS** (PRTTDCIS-2674)

~~SRS-724~~ The Medium UAM shall adhere to the implementation concept illustrated on following picture.

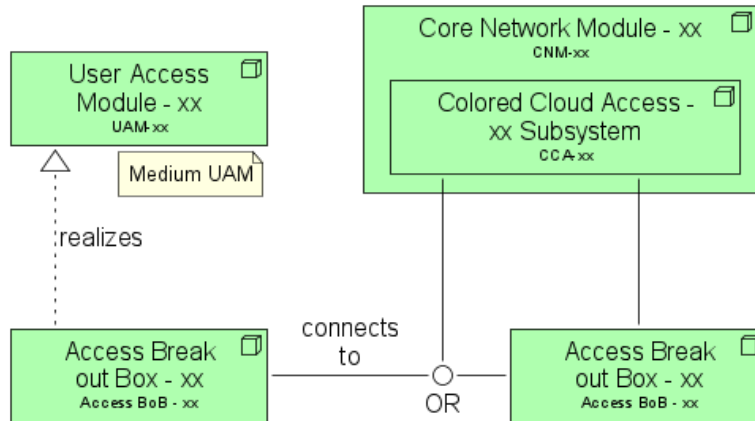

Figure 74 - Medium UAM implementation concept

**SRS** (PRTTDCIS-4213)

~~SRS-725~~ The UAM shall deliver Power over Ethernet (PoE) to voice appliances.

**SRS** (PRTTDCIS-4215)

~~SRS-726~~ Each UAM subsystem shall implement additional interfaces, as required and as driven by the design, in support of service management and control functionalities.

**NOTE** (PRTTDCIS-4216)

[172] Additional interfaces may be implemented to accommodate other connections and endpoints resulting from the detailed design.

**SRS** (PRTTDCIS-4217)

~~SRS-727~~ All UAM subsystems component shall be duly sized and licensed in order to meet all functional and technical requirements.

**SRS** (PRTTDCIS-4218)

~~SRS-728~~ All UAM subsystems shall be built and licensed the same, irrespective of the security domain.

**5.6.2 Functional Requirements**

**SRS** (PRTTDCIS-1273)

~~SRS-729~~ The Access BoB shall be detachable.

**SRS** (PRTTDCIS-2675)

~~SRS-730~~ The Access BoB shall support:

- Direct connection to the Core Switching part of the CCA; and,
- Connection via a second Access BoB (Daisy Chaining).

**SRS** (PRTTDCIS-1786)

~~SRS-734~~ The UAM shall deliver PoE to xU, xR and xS voice appliances.

**SRS** (PRTTDCIS-2457)

~~SRS-732~~ The UAM shall not deliver PoE to NS Kit voice appliances.

**SRS** (PRTTDCIS-1787)

~~SRS-733~~ The UAM shall implement a dedicated UPS functionality, giving the UAM the ability to continue to operate through mains power outage and power quality deficiencies, including the PoE power for xU, xR and xS voice appliances, but not including power for client laptops.

**SRS** (PRTTDCIS-1278)

~~SRS-734~~ The UAM-xU shall offer both wired and WiFi user access.

**SRS** (PRTTDCIS-1279)

~~SRS-735~~ UAM-xR and UAM-xS shall only offer wired user access.

## 5.6.3 Technical Requirements

### 5.6.3.1 General

**SRS** (PRTTDCIS-1797)

~~SRS-736~~ The Access BoB interfaces shall be implemented as follows:

- 1) Interface to the CNM; and,
- 2) Interface to a second UAM; and,
- 3) Interface to the user appliances (laptop, phones, VTC appliances, printer/scanners...), wired; and,
- 4) Interface to the user appliances (laptop, phones, VTC appliances, printer/scanners...), wireless on UAM-xU only.

**SRS** (PRTTDCIS-1799)

~~SRS-737~~ Interfaces to the CNM and to a second UAM shall be implemented on bulkhead connectors compatible with the FO Cable Reel.

**SRS** (PRTTDCIS-1814)

~~SRS-738~~ The UAM-xU shall include a Wireless Access Point (WAP).

**SRS** (PRTTDCIS-1795)

~~SRS-739~~ The UPS element shall implement UPS monitoring signaling changes in status and critical capacity warnings towards the LMM and visual and audio signals from the UPS itself.

**SRS** (PRTTDCIS-1794)

~~SRS-740~~ If UAM Elements shutdown require graceful shutdown, the UPS element shall implement this graceful shutdown mechanism.

**SRS** (PRTTDCIS-1793)

~~SRS-741~~ The UPS element shall implement ability for the UAM to continue to operate through:

- 1) Mains or generator power blackout for at least 30 minutes for xS, xR and xU not including telephones; and,
- 2) Mains or generator power blackout for at least 10 minutes for xU, xR and xS including 75% of the ports powering a PoE powered VoIP telephone; and,
- 3) Mains or generator power brownouts indefinitely for xS, xR and xU.

**SRS** (PRTTDCIS-4211)

~~SRS-742~~ Access BoB shall include patch panels in order to connect End User Devices to patch panel ports instead of connecting directly to Element ports.

**SRS** (PRTTDCIS-1800)

**SRS-743** The detailed system design of the Access BoB xU shall adhere to the breakdown depicted on the following figure:

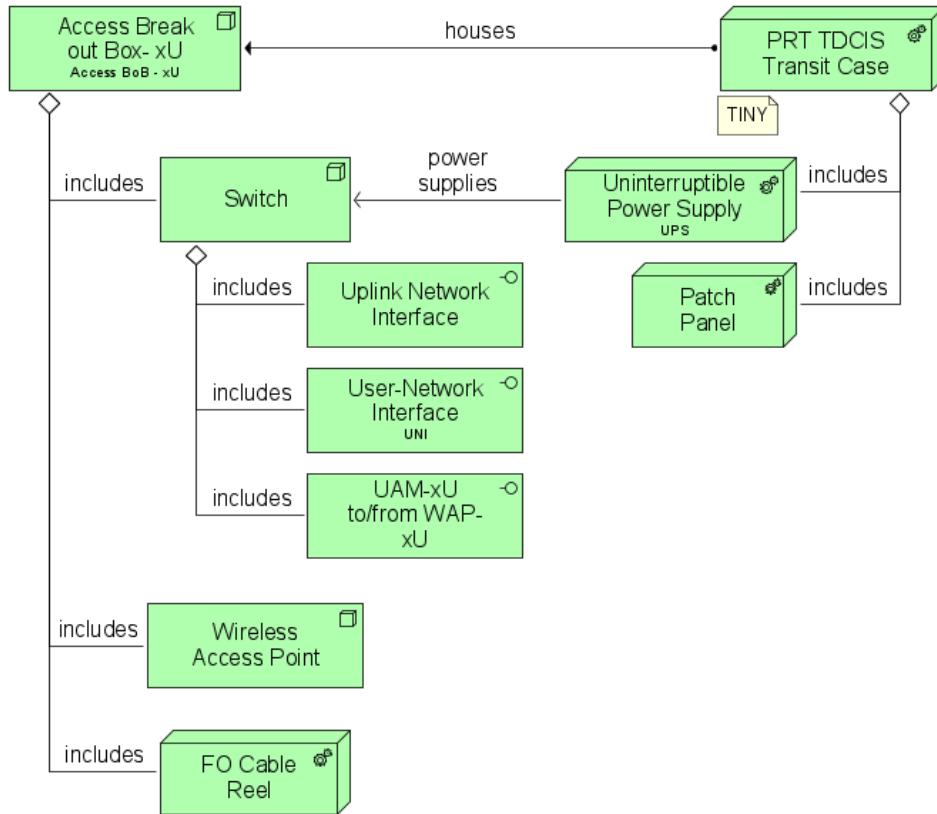

Figure 75 - Access BoB xU breakdown

**SRS (PRTTDCIS-3242)**

**SRS-744** The detailed system design of the Access BoB xR shall adhere to the breakdown depicted on the following figure:

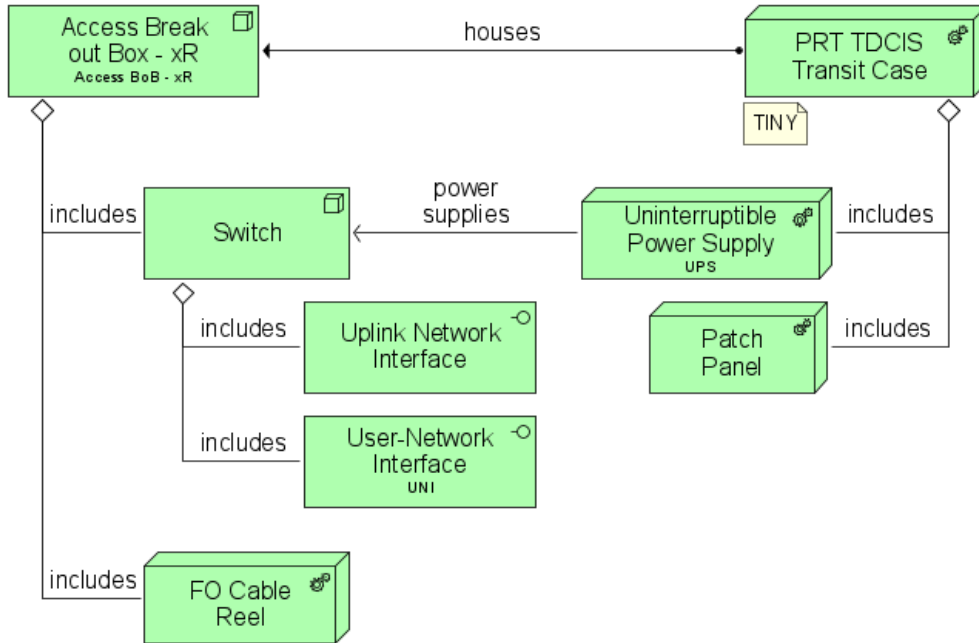

Figure 76 - Access BoB xR breakdown

**SRS (PRTTDCIS-3243)**

**SRS-745** The detailed system design of the Access BoB xS shall adhere to the breakdown depicted on the following figure:

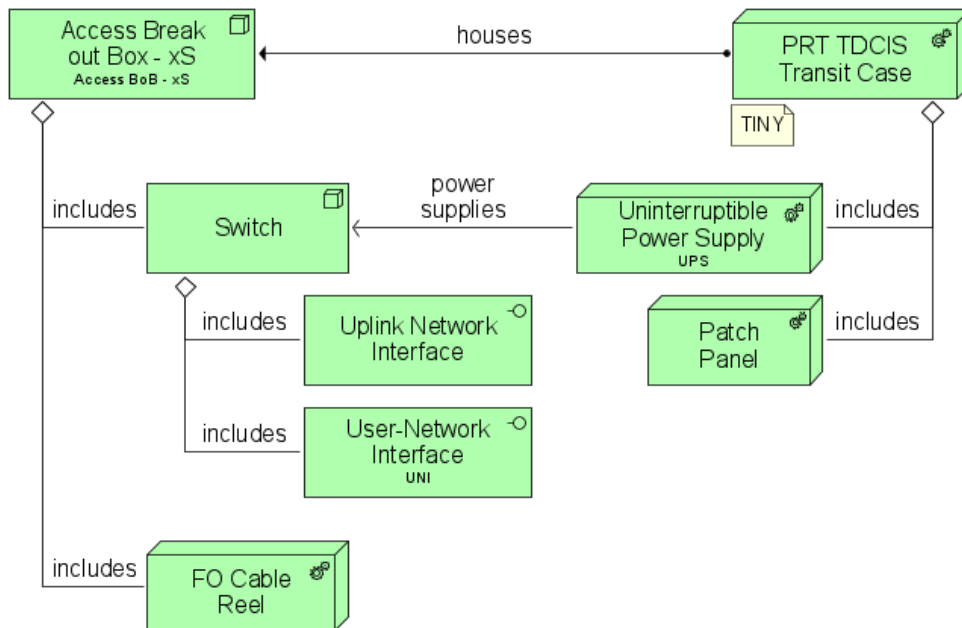

Figure 77 - Access BoB xS breakdown

### 5.6.3.2 Wireless Access Point

#### SRS (PRTTDCIS-3095)

~~SRS-746~~ All WAP shall be positioned to provide at least 2m separation from any CIS processing xS information.

#### SRS (PRTTDCIS-3100)

~~SRS-747~~ The UAM-xU WAP shall connect to a central Wireless LAN Controller (WLC) located the PRT NDN.

#### NOTE (PRTTDCIS-4210)

~~[473]~~ The WLC in operation in PRT NDN is a *Cisco WLC 3504* and is PFE to this project.

#### SRS (PRTTDCIS-4226)

~~SRS-748~~ The WAP shall support Wifi 6 as defined in IEEE 802.1ax

#### SRS (PRTTDCIS-4227)

~~SRS-749~~ The WAP shall include TWO (02) distinct radio.

#### SRS (PRTTDCIS-4228)

~~SRS-750~~ Each WAP radio shall operate in both 2.4GHz and 5.8GHz ISM bands.

#### SRS (PRTTDCIS-4229)

~~SRS-751~~ It shall be possible for the System Administrator to deploy the WAP away from the UAM-xU Transit Case up to a maximum distance of 5m.

#### SRS (PRTTDCIS-4230)

~~SRS-752~~ It shall be possible to mount the WAP on the external surface of the UAM-xU Transit Case in any Use Case.

#### SRS (PRTTDCIS-4231)

~~SRS-753~~ It shall be possible to operate the WAP while placed on a horizontal surface (e.g. table) without any additional mounting or mechanical base.

#### SRS (PRTTDCIS-4232)

~~SRS-754~~ The WAP shall support WPA2 Enterprise encryption.

#### SRS (PRTTDCIS-4233)

~~SRS-755~~ The WAP shall be powered through PoE.

## 5.6.4 Implementation Constraints

### SRS (PRTTDCIS-1789)

~~SRS-756~~ The Network element of the Access BoB shall be implemented with 24-port Ethernet switching capability featuring copper based ports, in support of laptops and ports with PoE for VoIP phones.

### SRS (PRTTDCIS-1801)

~~SRS-757~~ Access BoB switches shall support a minimum 2Gbps uplinks to the core switches in the corresponding CNM.

### SRS (PRTTDCIS-1803)

~~SRS-758~~ The interface to a second Access BoB shall be of minimum 2Gbps.

### SRS (PRTTDCIS-1804)

~~SRS-759~~ The Elements which compose the detachable Access BoB shall be integrated in TINY transit cases.

### SRS (PRTTDCIS-1275)

~~SRS-760~~ Each shelter shall also provide wireless xU network access via a WAP installed in the shelter.

### SRS (PRTTDCIS-4648)

~~SRS-761~~ The WAP installed in the shelter shall be detachable to be removed and mounted outside of the shelter.

### SRS (PRTTDCIS-2378)

~~SRS-762~~ The Access BoB shall have an electrical connection to 230VAC supply with protection against spikes, surges, overvoltage.

### SRS (PRTTDCIS-3229)

~~SRS-763~~ Each Access BoB shall be delivered with ONE (01) FO Cable Reel to be used to connect to the CNM or another Access BoB.

### SRS (PRTTDCIS-3823)

~~SRS-764~~ UAM-xU Access BoB Ethernet ports to EUD shall not be of SFP type.

### SRS (PRTTDCIS-3824)

~~SRS-765~~ UAM-xR Access BoB Ethernet ports to EUD shall not be of SFP type.

**SRS** (PRTTDCIS-4649)

~~SRS-766~~ UAM-xU Access BoB shall primarily use the FO Cable Reel to connect to the Shelter Termination Panel.

**SRS** (PRTTDCIS-4650)

~~SRS-767~~ UAM-xU Access BoB shall support the use a SFTP Cable Reel to connect to the Shelter Termination Panel.

**SRS** (PRTTDCIS-4651)

~~SRS-768~~ UAM-xR Access BoB shall primarily use the FO Cable Reel to connect to the Shelter Termination Panel.

**SRS** (PRTTDCIS-4652)

~~SRS-769~~ UAM-xR Access BoB shall support the use a SFTP Cable Reel to connect to the Shelter Termination Panel.

**SRS** (PRTTDCIS-4653)

~~SRS-770~~ UAM-xS Access BoB shall use the FO Cable Reel to connect to the Shelter Termination Panel.

## 5.7 Data Diode Module

### 5.7.1 General

**NOTE** (PRTTDCIS-4318)

~~[174]~~ This section describes the Data Diode Module (DDM).

**NOTE** (PRTTDCIS-4321)

~~[175]~~ The DDM is used to maintain physical and electrical separation between networks of a lower classification (The Low Side) and networks of a higher classification (The High Side) while establishing a non-routable, completely closed and secure one-way transfer of data traffic flow from The Low Side to The High Side, preventing data traffic from travelling in the opposite direction.



### 5.7.2 Functional Requirements

**SRS (PRTTDCIS-4322)**

~~SRS-774~~ The DDM shall fulfil following functions:

- 1) Create a physical barrier or *air gap* between the high side and low side to prevent data leakage from The High Side to The Low Side; and,
- 2) Provide unidirectional traffic flow and securely transmits data one way from The Low Side to The High Side without permitting reverse access to ensure that no leakage returns back; and,
- 3) Allow The High Side networks, that would otherwise be completely isolated for security reasons, to receive data from The Low Side networks without the risk of loss of confidentiality.

**SRS (PRTTDCIS-4323)**

~~SRS-772~~ The DDM shall support the secure transfer of multiple protocols and data types simultaneously from The Low Side to The High Side without creating bottlenecks.

**SRS (PRTTDCIS-4324)**

~~SRS-773~~ The DDM shall adhere to the implementation concept illustrated on following picture.

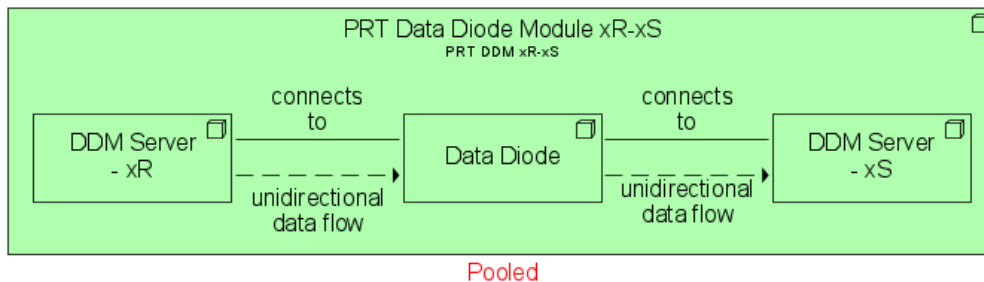

Figure 78 - DDM implementation concept

**SRS (PRTTDCIS-4325)**

~~SRS-774~~ The DDM shall include:

- a low side server; and,
- a data diode appliance; and,
- a high side server.

**SRS (PRTTDCIS-4326)**

~~SRS-775~~ This project shall implement a DDM between xR as the The Low Side and xS as The High Side.

**SRS (PRTTDCIS-4327)**

~~SRS-776~~ The DDM Shall support to be installed with xU as The Low Side and xR as the High Side.

### 5.7.3 Technical Requirements

**NOTE** (PRTTDCIS-4358)

[476] The following picture illustrates the DDM in context.

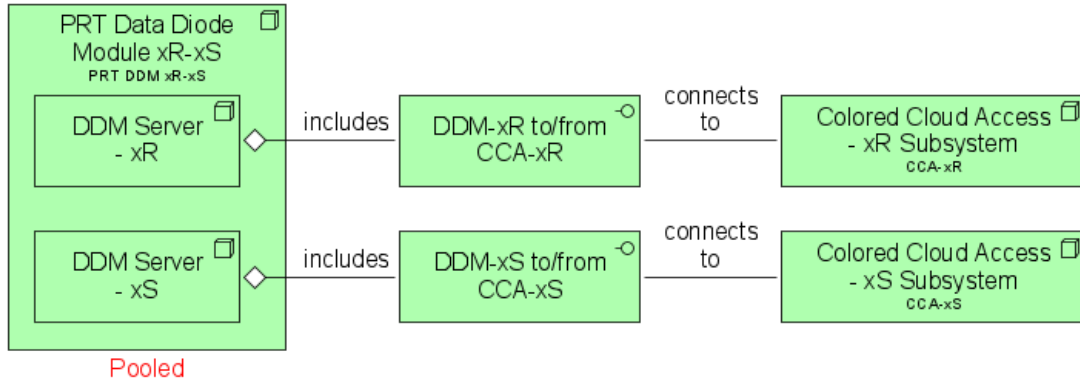

Figure 79 - DDM in context

**SRS** (PRTTDCIS-4359)

**SRS-777** Each individual DDM shall, as a minimum, implement interfaces to other modules subsystems as per the table below. The need for additional interfaces, or interfaces different from those listed below, as well as their specification, shall be design-driven and shall be justified, based on component selection and functionality sought.

Interface Name	Qty.	Interface Type	Interface Speed	Remarks
CCA-xR to/from PRT DDM xR-xS	R	Design Driven	Minimum 1Gbps	R is Design Driven
CCA-xS to/from PRT DDM xR-xS	S	Design Driven	Minimum 1Gbps	S is Design Driven

Table 37 - DDM interfaces

**SRS** (PRTTDCIS-4330)

**SRS-778** The DDM shall support file transfer across the data diode at a minimum of 1Gbps .

**SRS** (PRTTDCIS-4331)

**SRS-779** The Network Interface Cards (NIC) between DDM servers and the diode appliances shall be compatible with the diode software.

**SRS** (PRTTDCIS-4332)

**SRS-780** The DDM shall enforce the one-way flow of data from a network of a lower classification to a network of a higher classification through the physical properties of the unidirectional flow of fiber optic connections.

**SRS** (PRTTDCIS-4333)

~~SRS-781~~ For the avoidance of doubt, no data stream or signaling shall be returned to The Low Side from The High Side at any time.

**SRS** (PRTTDCIS-4334)

~~SRS-782~~ Both low and high side servers shall provide flow control, administration, and inspection capabilities.

**SRS** (PRTTDCIS-4335)

~~SRS-783~~ The DDM shall implement following modes of information transfer:

- 1) Files (including but not limited to, plain text and binary data); and,
- 2) E-mail compliant with the relevant IETF RFC standards such as RFC2822 and RFC5321 relating to Simple Mail Transfer Protocol (SMTP); and,
- 3) Network-streamed data transfers using Transmission Control Protocol (TCP) and User Datagram Protocol (UDP).

**SRS** (PRTTDCIS-4336)

~~SRS-784~~ The DDM shall implement filtering based on lists of Fully Qualified Domain Names (FQDN), with both blocking and permitting rules.

**SRS** (PRTTDCIS-4337)

~~SRS-785~~ The DDM shall implement data filters via file type identification based on the following common data formats as a minimum:

- 1) PDF; and,
- 2) Microsoft Office (binary and Open XML); and,
- 3) HTML; and,
- 4) XML; and,
- 5) RTF; and,
- 6) ZIP; and,
- 7) Common image formats such as JPEG, PNG, BMP; and,
- 8) Every type of executable binaries and script executables.

**SRS** (PRTTDCIS-4338)

~~SRS-786~~ The DDM shall support configurable data formats filtering, including but not limited to Portable Document Formats (PDF) and Microsoft Office document formats, to perform inspection on the files and e-mails transferred. This includes content inspections for both message file attachments and message body for e-mails.

**SRS** (PRTTDCIS-4339)

~~SRS-787~~ The DDM shall implement data filters on both The Low Side and The High Side.

**SRS** (PRTTDCIS-4340)

~~SRS-788~~ The DDM shall inspect the content of all transferred data with the Antivirus Toolsuite.

**SRS** (PRTTDCIS-4341)

~~SRS-789~~ The Contractor shall install and configure all DDM rules and policies for enforcement of the Purchaser business rules.

**NOTE** (PRTTDCIS-4342)

~~[177]~~ The Purchaser business rules will be provided after CAW.

**SRS** (PRTTDCIS-4343)

~~SRS-790~~ The Purchaser's list of approved FQDNs shall be implemented for the purpose of filtering email communication between The Low Side and The High Side. This shall include all email domain filtering and FQDNs, file types, content inspection, and handling/quarantine policies.

**SRS** (PRTTDCIS-4344)

~~SRS-791~~ The DDM shall integrate with the LMM, including but not limited to:

- domain management; and,
- antivirus toolsuite scan and updates; and,
- vulnerability patching on both the Operating System (OS) and at the middleware levels.

**SRS** (PRTTDCIS-4345)

~~SRS-792~~ The DDM shall support file transfer using the Server Message Block (SMB) protocol minimum v3.

**SRS** (PRTTDCIS-4346)

~~SRS-793~~ The DDM reporting capability, integrated with the LMM reporting capability, based on file, e-mail and data that are transmitted via the DDM shall include as a minimum:

- 1) E-mail transfers with the sender, recipient, date and size information in a specific period of time; and,
- 2) The status of data transmitted data (successful/rejected); and,
- 3) The name and the path of the file that is transmitted; and,
- 4) Network data stream information.

**SRS** (PRTTDCIS-4347)

~~SRS-794~~ The DDM shall support administratively-defined audit policies for the following activities:

- 1) Administrative, data transfer, and system maintenance activity, including but not limited to: system and user activity as well as logging for applications such as file and data transfer agents; and,
- 2) User administration, including the creation, removal, and modification of user accounts; and,
- 3) Privileged user actions, including the modification of security settings; and,
- 4) Transfer of data through the DDM, including the relevant meta-data such as filename, file sizes, and administrative tags; and,
- 5) Interactions with file and data transfer agents, including activity related to content checking and antivirus scanning.

**SRS** (PRTTDCIS-4348)

~~SRS-795~~ The DDM shall be enabled to support integration in the future LogA Service Infrastructure.

**SRS** (PRTTDCIS-4349)

~~SRS-796~~ It shall be possible to manage the DDM from the LMM.

**SRS** (PRTTDCIS-4350)

~~SRS-797~~ It shall be possible to manage the DDM directly from its composing elements.

**SRS** (PRTTDCIS-4351)

~~SRS-798~~ The Contractor shall design the DDM in such a way that its elements on

- The Low Side are managed from The Low Side LMM; and
- The High Side are managed from The High Side LMM.

**SRS** (PRTTDCIS-4352)

~~SRS-799~~ The DDM shall provide secure remote access functionality to its server elements which are suitable for the operating system of the server. For example, a system based on Linux shall expose a remote management access facility via Secure Shell (SSH) latest version which is considered secure by time of deployment.

**SRS** (PRTTDCIS-4353)

~~SRS-800~~ The DDM shall include functionality to generate and alert upon the absence of a heartbeat signal from The Low Side to The High Side, to facilitate awareness of a link or system failure in the DDM transport chain.

**SRS** (PRTTDCIS-4354)

~~SRS-801~~ The DDM heartbeat functionality shall integrate with the LMM Monitoring.

**SRS** (PRTTDCIS-4355)

~~SRS-802~~ The DDM shall integrate with the Node user authentication and authorization mechanism.

**SRS** (PRTTDCIS-4356)

~~SRS-803~~ DDM shall support users authentication based on locally-stored user name and password credentials.

#### 5.7.4 Implementation Constraints

**SRS** (PRTTDCIS-4357)

~~SRS-804~~ The DDM shall be implemented with dedicated hardware.

**SRS** (PRTTDCIS-4328)

~~SRS-805~~ The DDM shall be sourced from non-archived diodes listed in the NIAPC.

**SRS** (PRTTDCIS-4329)

~~SRS-806~~ The diode component of the DDM shall be evaluated to CC EAL 7 or national equivalent by a NATO national security authority as stated in the NIAPC.

## 5.8 Remote Network Module

### 5.8.1 General

**SRS** (PRTTDCIS-2718)

~~SRS-807~~ The design of the RNM and its variants shall adhere to the architecture and the breakdown presented in following figure.

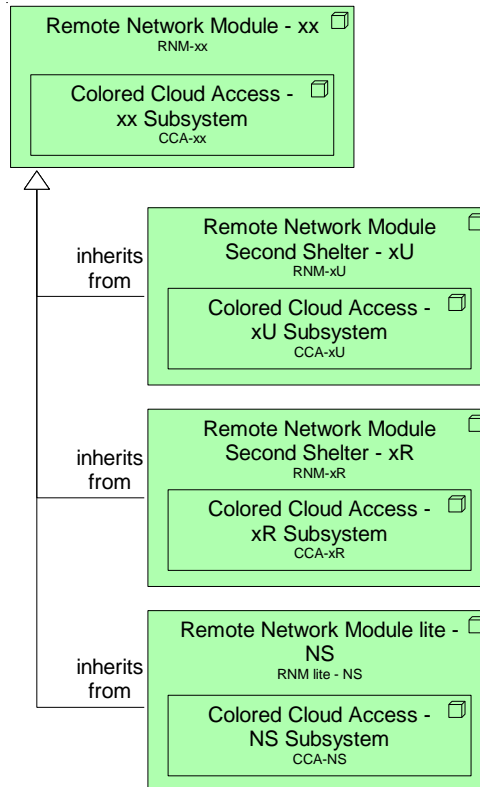

Figure 80 - RNM Architecture Breakdown

### 5.8.2 Functional Requirements

**SRS** (PRTTDCIS-2701)

~~SRS-808~~ The RNM shall implement the CCA function.

### 5.8.3 Technical Requirements

#### 5.8.3.1 CCA subsystem

**SRS** (PRTTDCIS-2710)

~~SRS-809~~ The CCA subsystem in the RNM shall implement the functions listed under the CCA function in the CNM.

**SRS** (PRTTDCIS-2711)

~~SRS-810~~ The CCA subsystem in the RNM shall meet the same technical requirements formulated for the CCA subsystem of the CNM, excluding the 10Gbps Core Switching.

**SRS** (PRTTDCIS-2712)

~~SRS-814~~ The CCA subsystem of the RNM lite shall, as a minimum, implement interfaces as per the table below. The need for additional interfaces, or interfaces different from those listed below, as well as their specification, shall be design-driven and shall be justified, based on component selection and functionality sought.

Interface Name	Qty.	Interface Type	Interface Speed	Remarks
CCA-NS to UAM-NS	P	Design Driven	Design Driven	P is Design Driven
PCA to/from NS Kit	1	Eth-FO-SR	1Gbps	Interface can be connected to the TCE621M of the CCA-NS of a Core Node Lite or of a Remote Node Lite

Table 38 - RNM lite CCA subsystem interfaces

**SRS** (PRTTDCIS-4654)

~~SRS-812~~ The CCA subsystem of the RNM Second Shelter – xU shall, as a minimum, implement interfaces as per the table below. The need for additional interfaces, or interfaces different from those listed below, as well as their specification, shall be design-driven and shall be justified, based on component selection and functionality sought.

Interface Name	Qty.	Interface Type	Interface Speed	Remarks
CCA-xU to/from Voice over IMT	M	Design Driven	Design Driven	M is Design Driven For transport to MMA-xU
CCA-xU to/from Iridium PTT	P	Design Driven	Design Driven	P is Design Driven For transport to MMA-xU
CCA-xU to/from Radio PTT	Q	Design Driven	Design Driven	Q is Design Driven For transport to MMA-xU
PCA to/from RNM Second Shelter - CCA-xU	1	Eth-FO-SR	1Gbps	N/A

Table 39 - RNM Second Shelter – xU CCA subsystem interfaces



**SRS** (PRTTDCIS-4655)

~~SRS-813~~ The CCA subsystem of the RNM Second Shelter – xR shall, as a minimum, implement interfaces as per the table below. The need for additional interfaces, or interfaces different from those listed below, as well as their specification, shall be design-driven and shall be justified, based on component selection and functionality sought.

Interface Name	Qty.	Interface Type	Interface Speed	Remarks
CCA-xR to/from PRT CNR	T	Design Driven	Design Driven	T is Design Driven For Data over CNR direct interface on CCA routing platform For Transport of Voice to MMA-xR
PCA to/from Second RNM Second Shelter CCA-xR	1	Eth-FO-SR	1Gbps	N/A

Table 40 - RNM Second Shelter – xR CCA subsystem interfaces

**SRS** (PRTTDCIS-2720)

~~SRS-814~~ The CCA subsystems of the RNM shall be implemented using routers and switches compatible with the element management system for routing and switching platforms.

**5.8.4 Implementation Constraints**

**SRS** (PRTTDCIS-2734)

~~SRS-815~~ Crypto devices shall be removable from the transit cases of the RNM lite, for storage and transport.

**SRS** (PRTTDCIS-2742)

~~SRS-816~~ The removal of the crypto devices from the RNM lite shall be compatible with the implementation of TEMPEST requirements in the transit cases.

**NOTE** (PRTTDCIS-4374)

~~[178]~~ Foam-padded transport cases able to carry one TCE621M will be used for that purpose.

**NOTE** (PRTTDCIS-4373)

~~[179]~~ TCE621M transport cases are PFE and will be transported separately from the Node.

## 5.9 Local Management Module

### SRS (PRTTDCIS-2827)

~~SRS-817~~ The LMM shall adhere to the implementation concept illustrated on following picture.

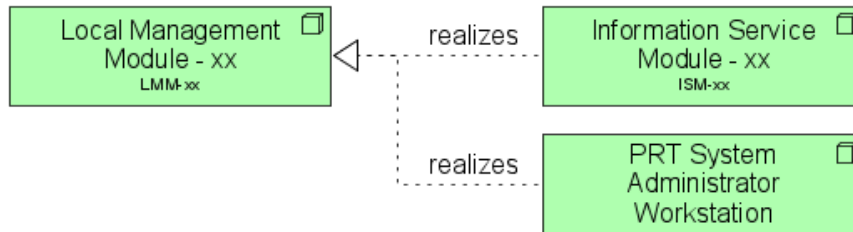

Figure 81 - LMM implementation concept

### SRS (PRTTDCIS-2993)

~~SRS-818~~ The LMM shall support TWO (02) implementations variants in each security domain of each Node:

- As a workload to the ISM; and
- As a workload to the System Administrator Workstation.

### SRS (PRTTDCIS-2994)

~~SRS-819~~ All LMM instances in the same security domain of a Node shall be independent from each other allowing each to work in isolation from the other and providing the exact same user experience, functionalities and performances.

## 6 Transmission Systems

### 6.1 Datalink

#### 6.1.1 General

##### **SRS** (PRTTDCIS-3057)

~~SRS-820~~ The datalinks shall interface the PCA subsystem of the CNM-PCN as IP Transmission System.

##### **SRS** (PRTTDCIS-3058)

~~SRS-824~~ The datalink Outdoor Units (ODU) shall be deployed on the top of the telescopic masts of Shelter.

##### **SRS** (PRTTDCIS-3059)

~~SRS-822~~ Each mast shall allow the installation of TWO (02) Datalink ODU (e.g. 2 MiniLOS, 2 HCLOS or 1 MiniLOS + 1 HCLOS).

##### **SRS** (PRTTDCIS-3061)

~~SRS-823~~ The datalinks ODUs, once mounted on the telescopic masts and deployed for operation, shall not interfere with, or be interfered by, any other transmission device or antenna of the node.

##### **SRS** (PRTTDCIS-3062)

~~SRS-824~~ The ODU of the datalinks shall be connected through an ad-hoc pass-through connector in the shelter's ELOS RP to the datalink IDU (if required) and from there to the PCA subsystem.

##### **SRS** (PRTTDCIS-3232)

~~SRS-825~~ The ODU of the datalinks power supply shall be Power over Ethernet (PoE).

##### **SRS** (PRTTDCIS-3063)

~~SRS-826~~ The datalink antennae shall be directional in support of a Peer-to-Peer (P2P) connection.

##### **SRS** (PRTTDCIS-3064)

~~SRS-827~~ The datalink antennae shall be equipped with an automatic pointing and alignment system (azimuth and elevation) that automatically establishes the P2P link to the selected remote peer datalink.

**NOTE** (PRTTDCIS-3065)

~~[180]~~ The aperture of the antenna is a design driven based on the deployment time, throughput, link distance, power, among other characteristics.

**SRS** (PRTTDCIS-3067)

~~SRS-828~~ The datalinks shall implement embedded AES-256 data encryption FIPS 197 certified.

**SRS** (PRTTDCIS-3068)

~~SRS-829~~ The datalinks shall support Traffic Flow Security (TFS).

**SRS** (PRTTDCIS-3069)

~~SRS-830~~ The datalinks shall support interference control and mitigation.

**SRS** (PRTTDCIS-3070)

~~SRS-831~~ The datalinks shall implement adaptive modulation.

**SRS** (PRTTDCIS-3071)

~~SRS-832~~ The datalinks shall implement Ethernet interfaces supporting IPv4, transparent Ethernet Bridge, Precision Time Protocol (PTP), Dynamic Host Configuration Protocol (DHCP) and IPv6 pass-through

**SRS** (PRTTDCIS-3072)

~~SRS-833~~ The datalinks shall be enabled for monitoring and control over Ethernet and Over The Air (OTA).

**SRS** (PRTTDCIS-3073)

~~SRS-834~~ The datalinks shall be Field and OTA upgradeable via HTTP/HTTPS.

## 6.1.2 Mini LOS Radio

**SRS** (PRTTDCIS-3081)

~~SRS-835~~ The MiniLOS datalink shall enable a Line of Sight (LOS) P2P IP datalink.

**SRS** (PRTTDCIS-3083)

~~SRS-836~~ The MiniLOS datalink shall operate in both 2.4GHz and 5.8GHz ISM bands.

**SRS** (PRTTDCIS-3085)

~~SRS-837~~ The MiniLOS datalink shall have a minimum LOS range of 40 km, featuring at this distance not less than 2.5 Mbps throughput.

**SRS** (PRTTDCIS-3086)

~~SRS-838~~ The MiniLOS datalink shall have a maximum throughput of not less than 50 Mbps.

### 6.1.3 HCLOS Radio

**SRS** (PRTTDCIS-3066)

~~SRS-839~~ The HCLOS datalink shall be Federal Information Processing Standards (FIPS) 140-2 Level 2 certified.

**SRS** (PRTTDCIS-3077)

~~SRS-840~~ The HCLOS datalink shall operate in NATO Band IV (4.4 - 5 GHz).

**SRS** (PRTTDCIS-3079)

~~SRS-841~~ The HCLOS datalink shall have a minimum LOS range of 50 km, featuring at this distance not less than 10 Mbps throughput.

**SRS** (PRTTDCIS-3080)

~~SRS-842~~ The HCLOS datalink shall have a maximum throughput of not less than 200 Mbps.

## 6.2 Broadband IP Radio

**SRS** (PRTTDCIS-3045)

~~SRS-843~~ The Broadband Radio shall be the Rohde & Schwarz SOVERON VR with following specifications:

- Model Type: VR5000;
- Model Name: VEHICULAR TACTICAL RADIO;
- Year of manufacture: 2022 or after;
- Waveforms:
  - Fixed Frequency; and,
  - Secom-P (voice); and,
  - HDR-WB (UHF WB); and,
  - HDR-AJ-WB (UHF WB-AJ); and,
  - TNW50 (VHF/UHF NB-AJ).

**SRS** (PRTTDCIS-4656)

~~SRS-844~~ Each Broadband Radio shall be delivered with, at least, following ancillaries:

- Mission Planner Software; and,
- ONE (01) Broadband Vehicular antenna (30-600 MHz); and,
- ONE (01) Handset; and,
- Mounting frame with quick fastener; and,
- Power Supply cable; and,
- Ethernet cable.

**SRS** (PRTTDCIS-4657)

~~SRS-845~~ For the configuration and management of all TDCIS Broadband Radios following ancillaries shall also be delivered:

- FIVE (05) FillGun to install the mission configuration on the VR5000; and,
- FIVE (05) Fill cables for connecting the fill device to the VR5000.

## 6.3 Commercial SATCOM Terminal

### 6.3.1 Functional Requirements

**SRS** (PRTTDCIS-2047)

~~SRS-846~~ The Commercial SATCOM shall provide data and voice subscriber access services using the BGAN service of Inmarsat. This shall involve:

- 1) IP connectivity using Background Service, pay per byte, to any location in the Internet; and,
- 2) IP connectivity using Background Services, pay per byte, or Streaming Services, pay per minute, to the PRT Static Infrastructure, without involving any Internet transit; and,
- 3) PSTN connectivity.

### 6.3.2 Technical Requirements

**SRS** (PRTTDCIS-2050)

~~SRS-847~~ The Commercial SATCOM terminal shall provide 492 kbps shared standard IP data rate (best effort) and up to 256 kbps streaming IP data rate, with QoS at intermediate data rates of 32 kbps, 64 kbps, 128 kbps and 256 kbps.

**SRS** (PRTTDCIS-2051)

~~SRS-848~~ The Commercial SATCOM terminal shall support BGAN X-stream mode up to the service maximum bandwidth of 384 kbps.

**SRS** (PRTTDCIS-2052)

~~SRS-849~~ Changes to the mode of operation (standard IP, streaming, X-stream) shall be possible without the use of an external laptop.

**SRS** (PRTTDCIS-2063)

~~SRS-850~~ The Commercial SATCOM terminal shall be compatible with future INMARSAT (INMARSAT IV+) constellation; upgradeable to future operations on Wide-Band Streaming L-Band (WiSL).

**SRS** (PRTTDCIS-2053)

~~SRS-851~~ The Commercial SATCOM terminal shall support circuit-switched telephony access to the Public Switched Telephone Network (PSTN).

**SRS** (PRTTDCIS-2054)

~~SRS-852~~ The Commercial SATCOM terminal shall support the use of PFE SIM cards and connectivity-related specific settings, and use of specific terminal settings including disabling of interfaces, administrator access, allowed services, maximum session duration.

**SRS** (PRTTDCIS-2056)

~~SRS-853~~ The Commercial SATCOM terminal shall operate outdoors over a temperature range from -20 deg. C to +55 deg. C

**SRS** (PRTTDCIS-2058)

~~SRS-854~~ The Commercial SATCOM terminal shall implement IP 56 protection against water and dust, or higher.

## 6.4 Military SATCOM Terminal

### 6.4.1 General

**NOTE** (PRTTDCIS-2064)

~~[181]~~ The Military SATCOM Terminal will provide reach-back connectivity to PRT NDN.

**NOTE** (PRTTDCIS-2665)

~~[182]~~ The Military SATCOM Terminal will only be used in Point-to-Point topology.

**NOTE** (PRTTDCIS-2668)

~~[183]~~ The Military SATCOM Terminal will provide intra-theatre connectivity.

### 6.4.2 Functional Requirements

**SRS** (PRTTDCIS-2066)

~~SRS-855~~ The Military SATCOM Terminal shall enable communications over this bearer.

**SRS** (PRTTDCIS-4407)

~~SRS-856~~ The Military SATCOM Terminal shall implement functions as illustrated in the following diagram.

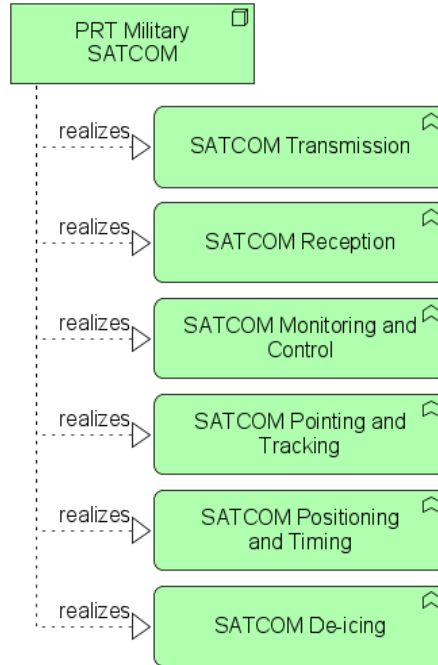

Figure 82 - Military SATCOM Terminal functions



### 6.4.3 Technical Requirements

#### 6.4.3.1 General

**SRS** (PRTTDCIS-4408)

~~SRS-857~~ The Military SATCOM Terminal design shall adhere to the breakdown concept described in the following diagram.

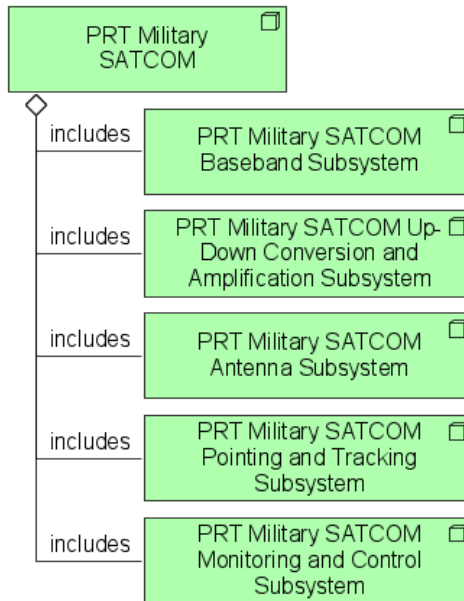

Figure 83 - Military SATCOM Terminal breakdown

**SRS** (PRTTDCIS-2065)

~~SRS-858~~ The TDCIS Military SATCOM terminal shall operate in

- X-band (7.9GHz to 8.4GHz Transmission and 7.25GHz to 7.75GHz Reception); and,
- Ka-band (29 to 31GHz Transmission and 19.2 to 21.2GHz Reception).

**SRS** (PRTTDCIS-2071)

~~SRS-859~~ The Military SATCOM Terminal shall support links up to 20 Mbps in all bands.

**SRS** (PRTTDCIS-2072)

~~SRS-860~~ Should the Contractor, based on Service Designs, conclude that a higher throughput is required, this shall be duly justified and left for the Purchaser to assess and approve.

### 6.4.3.2 Baseband Subsystem

#### SRS (PRTTDCIS-2084)

~~SRS-861~~ For compatibility with the extant systems in PRT, the Military SATCOM Terminal shall include:

- 1) ONE (01) iDirect 950 MP series modem; and,
- 2) ONE (01) Comtech SLM5650B (STANAG 4486 Compliant).

#### SRS (PRTTDCIS-2085)

~~SRS-862~~ The Military SATCOM Terminal shall include ONE (01) free RU slot with blanking plate, to allow for future addition of new modem (compliant with future STANAG 5646).

#### SRS (PRTTDCIS-2088)

~~SRS-863~~ The Military SATCOM Terminal shall include the required elements to allow for switching of modems without the need for re-patching.

### 6.4.3.3 Up-Down Conversion and Amplification Subsystem

#### SRS (PRTTDCIS-4409)

~~SRS-864~~ The Military SATCOM Terminal shall include GaN-based amplifiers.

#### SRS (PRTTDCIS-4410)

~~SRS-865~~ The Up and Down Conversion Subsystem shall accept external 10MHz reference input.

#### SRS (PRTTDCIS-4411)

~~SRS-866~~ To accommodate any loss of external frequency reference, (block) up and down converters shall have internal 10 MHz frequency reference with an accuracy better than +/- 30 ppb.

#### SRS (PRTTDCIS-4412)

~~SRS-867~~ The Voltage Standing-Wave Ratio (VSWR) over the IF band shall be less than 1.5:1

#### SRS (PRTTDCIS-4413)

~~SRS-868~~ The Up Conversion part of the Up and Down Conversion Subsystem shall have a transmission output signal sampling port.

#### SRS (PRTTDCIS-4414)

~~SRS-869~~ The radiated carrier frequency accuracy shall be within 1 kHz of the intended value for all RF carriers.

**SRS** (PRTTDCIS-4415)

~~SRS-870~~ The radiated carrier frequency accuracy shall be maintained for 180 days period or more without calibration.

**SRS** (PRTTDCIS-4416)

~~SRS-874~~ Amplitude variations of the transmit (uplink) function when operating at maximum linear power shall not exceed the following:

- 1) +/- 0.5 dB over any 10 MHz segment across the instantaneous bandwidth; and,
- 2) +/- 1.5 dB over any 120 MHz segment, or any smaller segment, across the instantaneous bandwidth (10 MHz < segment < 120 MHz) ; and,
- 3) +/- 1.5 dB for each output frequency band in X and Ka-bands.

**SRS** (PRTTDCIS-4417)

~~SRS-872~~ The sum of the fundamental and all harmonic components of the Alternating Current (AC) line frequency shall not exceed -30 dBc in the Transmission Path.

**SRS** (PRTTDCIS-4418)

~~SRS-873~~ The single sideband sum (added on a power basis) of all other individual spurious components shall not exceed -36 dBc in the Transmission Path.

**SRS** (PRTTDCIS-4419)

~~SRS-874~~ The single sideband Power Spectral Density (PSD) of the continuous phase noise component shall comply with the envelope defined in the following figure (as per STANAG 5648). If specific points associated with the measured phase noise plot exceed the envelope, then the following two conditions shall be met:

- 1) The single sideband phase noise due to the continuous component, when integrated over the bandwidth from 10 Hz to 16 kHz relative to carrier center frequency, shall be less than 3.4 degrees Root Mean Square (RMS) (with a two-sided value of 4.8 degrees RMS); and,
- 2) The single sideband phase noise due to the continuous component, when integrated over the bandwidth from 1 percent of the Symbol Rate ( $R_s$ ) to  $R_s$  Hz relative to the carrier center frequency, shall be less than the value obtained when integrating the following figure plot over the same limits. This requirement shall be verified at the lowest and highest symbol rates. This requirement applies to all operational  $R_s$  values.

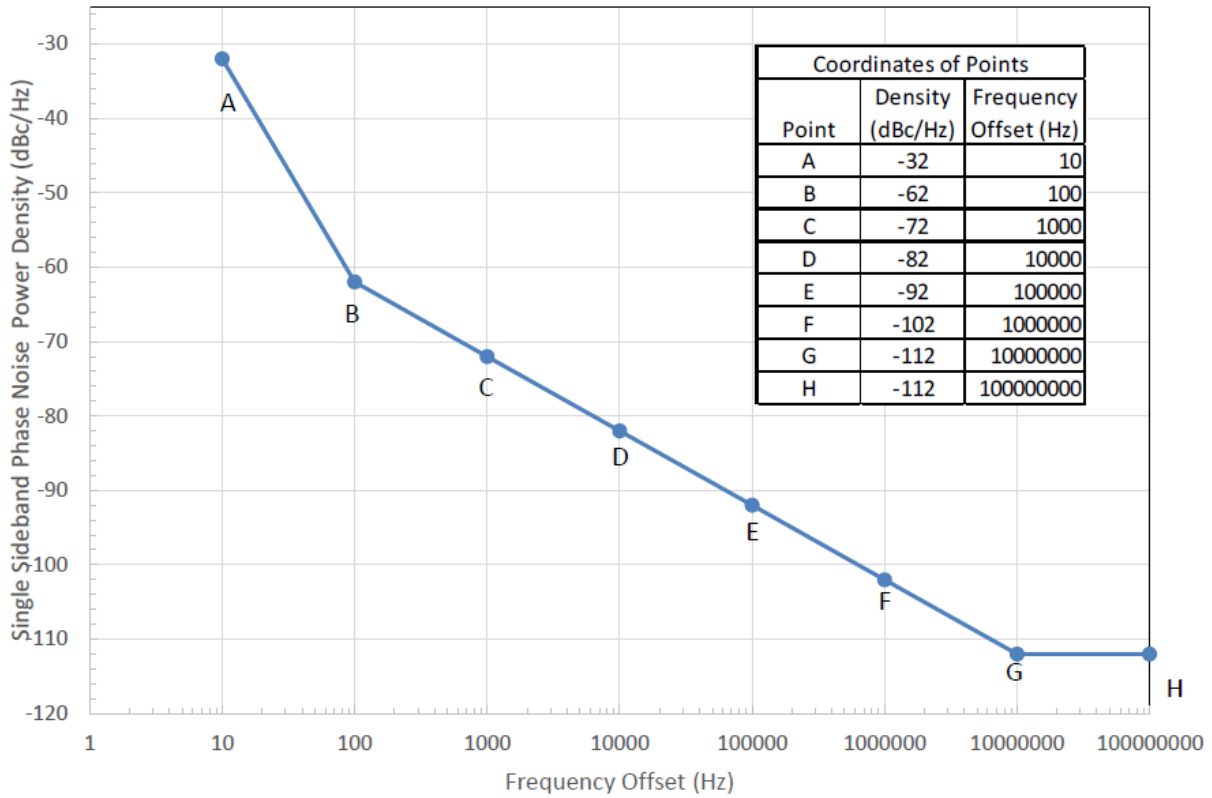

Figure 84 - Military SATCOM Terminal Phase Noise envelope as per STANAG 5648.

**SRS** (PRTTDCIS-4420)

~~SRS-875~~ The level of second and third harmonics of the transmit carriers shall not exceed -60 dBc when measured at maximum linear power.

**SRS** (PRTTDCIS-4421)

~~SRS-876~~ Transmit-to-receive isolation shall be such that there is less than a 0.1 dB increase, and no decrease, in receive noise density over the applicable frequency range with the transmitter operating at any Effective Isotropic Radiated Power (EIRP) level, compared to the receive performance with the transmitter turned off.

**SRS** (PRTTDCIS-4422)

~~SRS-877~~ When pointing to a cold sky at an elevation angle of not less than 30 degrees, the receive chain absolute gain shall be sufficient to raise the IF output noise PSD to a minimum of -113 dBm/Hz.

**SRS** (PRTTDCIS-4423)

~~SRS-878~~ The Down Conversion frequency accuracy shall be within 1kHz of the intended value for all received RF carriers.

**SRS** (PRTTDCIS-4424)

~~SRS-879~~ The Down Conversion frequency accuracy shall be maintained for 180 days period or more without calibration.

**SRS** (PRTTDCIS-4425)

~~SRS-880~~ Amplitude variations as measured at the IF output (demodulator input) shall not exceed the following:

- 1) +/-0.5 dB over any 10 MHz segment across the instantaneous bandwidth; and,
- 2) +/-1.5 dB over any 120 MHz segment or smaller segment across the instantaneous bandwidth (10 MHz < segment < 120 MHz); and,
- 3) +/-1.5 dB for each output frequency band in X and Ka-bands.

**SRS** (PRTTDCIS-4426)

~~SRS-881~~ No spectral inversion shall exist between any RF input and the IF output of the system in the Receiving Path.

**SRS** (PRTTDCIS-4427)

~~SRS-882~~ For any setting of the receive gain and for a constant Power Spectral Density (PSD) level, the reception function output level shall not vary more than +/-1.5 dB in any 24 hour period.

**SRS** (PRTTDCIS-4428)

~~SRS-883~~ The Military SATCOM Terminal shall include all necessary specific adapter (such as Bias-Tee) in order to power and trouble-shoot the Amplifier and Down Conversion Elements,

**SRS** (PRTTDCIS-4429)

~~SRS-884~~ The Up and Down Conversion Subsystem Intermediate Frequency (IF) input and output interfaces shall be 50 Ohm N-Type connectors.

#### 6.4.3.4 Antenna Subsystem

**SRS** (PRTTDCIS-2067)

~~SRS-885~~ The Military SATCOM Terminal Antenna shall be in the vicinity of 2.4 m foldable antenna, configured for simultaneous operation for both X-band and Ka-band, with a single common RF feed.

**SRS** (PRTTDCIS-3857)

~~SRS-886~~ The antenna design shall be capable of simultaneously transmitting Right-Hand Circular Polarization (RHCP) and receiving Left-Hand Circular Polarization (LHCP) in all bands (normal polarization).

**SRS** (PRTTDCIS-3858)

~~SRS-887~~ The antenna design shall be capable of simultaneously transmitting LHCP and receiving RHCP in all bands (inverted polarization)

**NOTE** (PRTTDCIS-3859)

~~[184]~~ Simultaneous normal and inverted polarization is not required.

**SRS** (PRTTDCIS-3860)

~~SRS-888~~ The duration required to switch between normal and inverted polarization shall not exceed 20 minutes in any frequency band.

**SRS** (PRTTDCIS-2069)

~~SRS-889~~ The antenna design shall support Low Passive Intermodulation (Low-PIM) feed.

**SRS** (PRTTDCIS-2070)

~~SRS-890~~ The antenna reflector shall fold on the sides that auto-deploys and stows as needed.

**SRS** (PRTTDCIS-4430)

~~SRS-891~~ The radiation pattern of the antenna while both transmitting and receiving shall be in accordance with ITU-R S.580-6.

**SRS** (PRTTDCIS-4431)

~~SRS-892~~ The gain of the antenna,  $G$ , shall be such that at least 90 percent of the side lobe peaks do not exceed:

- $G(\theta) = 29 - 25 \log_{10}(\theta)$  dBi for  $1^\circ$  or  $100 \lambda / D_e$  (whichever is larger, up to  $2^\circ \leq \theta \leq 20^\circ$ )
- $G(\theta) = -3.5$  dBi for  $20^\circ < \theta \leq 26.3^\circ$
- $G(\theta) = 32 - 25 \log_{10}(\theta)$  dBi for  $26.3^\circ < \theta \leq 48^\circ$
- $G(\theta) = -10$  dBi for  $48^\circ < \theta \leq 180^\circ$

Where

- $G$  = gain relative to an isotropic antenna,
- $\theta$  = off-axis angle in the direction of the satellite referred to the main-lobe axis,
- $D_e$  = equivalent antenna diameter and  $\lambda$  = wavelength (same units as  $D_e$ ).

**SRS** (PRTTDCIS-4432)

~~SRS-893~~ The angular regions and allowed side-lobe peak excess shall be within the limits as defined below:

- 1 dB for  $\theta_{\min} < \theta \leq 7^\circ$ , where  $\theta_{\min} = 1^\circ$  or  $(100 \lambda / D_e)$  degrees, whichever is larger
- 3 dB for  $7^\circ < \theta \leq 9.2^\circ$
- 3 dB for  $9.2^\circ < \theta \leq 48^\circ$
- 10 dB for  $48^\circ < \theta \leq 180^\circ$

Where  $\theta$  = off-axis angle in the direction of the satellite referred to the main-lobe axis

**SRS** (PRTTDCIS-4433)

~~SRS-894~~ The Antenna Subsystem shall include a de-icing capability that removes snow and ice.

**SRS** (PRTTDCIS-4434)

~~SRS-895~~ The de-icing capability shall not affect RF performance of the Antenna Subsystem.

#### 6.4.3.5 Pointing and Tracking Subsystem

**SRS** (PRTTDCIS-4435)

~~SRS-896~~ The Military SATCOM Terminal shall include all the necessary devices needed to ensure appropriate initial pointing, re-pointing and permanent automatic tracking of a satellite.

**SRS** (PRTTDCIS-2073)

~~SRS-897~~ The Military SATCOM Terminal shall implement automatic pointing and tracking functionalities and allow a single setting auto-acquisition of selected satellites, including:

- 1) automatic deployment and stowing; and,
- 2) peaking and optimization; and,
- 3) Internal movement detector.

**SRS** (PRTTDCIS-2075)

~~SRS-898~~ The Military SATCOM Terminal shall enable an emergency Hand-crank/manual deployment and stowage, on Azimuth and Elevation axis.

**SRS** (PRTTDCIS-4436)

~~SRS-899~~ The Military SATCOM Terminal shall support manual pointing.

**SRS** (PRTTDCIS-4437)

~~SRS-900~~ The Military SATCOM Terminal shall be capable of tracking satellites by monitoring and maximising the level of a received signal, which can be selectable among the satellite beacon, a similar pseudo-beacon radiated by the satellite, the wide-band signal radiated by the satellite, or the receive signal strength indicator of any modem selected by the System Administrator.

**SRS** (PRTTDCIS-2074)

~~SRS-901~~ The Military SATCOM Terminal shall drive to calculated position based on GPS, Flux-Gate Compass (or Internal Reference Unit) data and satellite signal peaking.

**SRS** (PRTTDCIS-4438)

~~SRS-902~~ The antenna pointing shall be adjustable in two-axis with the minimum following parameters:

- 1) Azimuth: AZ (120 degrees range); and,
- 2) Elevation: EL (from 5 to 85 degrees) above the horizon.

**SRS** (PRTTDCIS-4439)

~~SRS-903~~ The manual pointing shall be adjustable in fine increments in azimuth with minimum 40 degrees range.

**SRS** (PRTTDCIS-4440)

~~SRS-904~~ The manual pointing shall be adjustable in fine increments in elevation with minimum 10 degrees range.

**SRS** (PRTTDCIS-4441)

~~SRS-905~~ Fine increments shall be such that the pointing loss from boresight does not exceed 0.2 dB in X-band.

**SRS** (PRTTDCIS-4442)

~~SRS-906~~ Fine increments shall be such that the pointing loss from boresight does not exceed 0.5 dB in Ka-band.

**SRS** (PRTTDCIS-4443)

~~SRS-907~~ The antenna auto-pointing and auto-tracking system shall allow re-pointing of the antenna in two-axis with a continuous range of motion with the following parameters:

- 1) Azimuth: minimum of 60 degrees; and,
- 2) Elevation: from 5 to 85 degrees above the horizon.



**SRS** (PRTTDCIS-4444)

~~SRS-908~~ The tracking Element shall consist, as a minimum but not limited to, the following elements:

- 1) Antenna Control Unit (ACU) and Beacon Receiver; and,
- 2) Axis Drive; and,
- 3) Axis control.

**6.4.3.6 Monitoring and Control Subsystem****SRS** (PRTTDCIS-2089)

~~SRS-909~~ The SATCOM Terminal shall include a Monitoring and Control Subsystem to fully monitor the system functionality and any performance degradation and perform fault detection and isolation down to LRU level integrated in the LMM-BLK.

**SRS** (PRTTDCIS-4445)

~~SRS-910~~ The Military SATCOM Terminal shall be able to be configured, monitored and operated without any third party equipment or software, using the LMM-BLK and its software, locally or remotely connected to the terminal components.

**SRS** (PRTTDCIS-4446)

~~SRS-911~~ Using the LMM-BLK, the System Administrator shall be able to fully monitor the system functionality and performance and perform fault detection and isolation down to LRU level.

**SRS** (PRTTDCIS-2090)

~~SRS-912~~ The Monitoring and Control Subsystem shall also feature:

- 1) Spectrum Monitoring, as drawn from spectrum analyser; and,
- 2) ON/OFF status of de-icing capability in case it is an active component; and,
- 3) Display of health and status information in a block diagram format, with colours reflecting current health and status of Line replaceable units (LRUs) in the following convention:
  - 1) Green – good acceptable performance within nominal parameters; and,
  - 2) Amber – unacceptable performance outside of nominal parameters; and,
  - 3) Red – element not functional.

**SRS** (PRTTDCIS-4447)

~~SRS-913~~ The following parameters shall be automatically acquired by the system and displayed within the Monitoring and Control application or screens:

- 1) The terminal longitude; and,
- 2) The terminal latitude; and,
- 3) Date and time (refreshed every second) in UTC.

**SRS** (PRTTDCIS-4448)

~~SRS-914~~ The travel limits of the antenna motion system shall be adjustable by the System Administrator.

**SRS** (PRTTDCIS-4449)

~~SRS-915~~ The Military SATCOM Terminal shall be equipped with physical travel limits (hardware limit) to prevent damage to the equipment.

**SRS** (PRTTDCIS-4450)

~~SRS-916~~ The Military SATCOM Terminal shall provide an emergency stop function of the antenna motion via the Monitoring and Control Subsystem, implemented as

- ONE (01) emergency button inside the Shelter; and,
- ONE (01) emergency button outside the Shelter; and,
- A software button always visible on the graphical user interface in the Monitoring and Control Tool Suite.

**SRS** (PRTTDCIS-2086)

~~SRS-917~~ The Military SATCOM Terminal shall include embedded spectrum analyzers function to monitor IF and RF interfaces.

**SRS** (PRTTDCIS-2087)

~~SRS-918~~ The Spectrum analysers function shall integrate with the monitoring and control software Tool suite.

**SRS** (PRTTDCIS-4658)

~~SRS-919~~ The elements realizing the Spectrum Analyzer function shall enable live Link monitoring from the Element Management Tool Suite.

**SRS** (PRTTDCIS-4451)

~~SRS-920~~ The Military SATCOM Terminal shall allow simultaneous spectrum monitoring of both IF and RF signals while the system is operational.

**SRS** (PRTTDCIS-4452)

~~SRS-921~~ The monitoring Light Emitting Diodes (LED), if any, shall be coherent throughout all the subsystems of the system.

#### 6.4.4 Implementation Constraints

**SRS** (PRTTDCIS-4453)

~~SRS-922~~ The Military SATCOM Terminal shall have, as a minimum, 21 dB/K G/T at 10 degrees elevation and 23 degrees Celsius ambient temperature in the X-band.

**SRS** (PRTTDCIS-4454)

~~SRS-923~~ The Military SATCOM Terminal shall have, as a minimum, 26 dB/K G/T at 10 degrees elevation and 23 degrees Celsius ambient temperature in the Ka-band.

**SRS** (PRTTDCIS-4455)

~~SRS-924~~ The Military SATCOM Terminal shall include waveguide equipment that enables rapid (less than 30 seconds) connection and disconnection, when required, without damaging the interconnecting components. No specific tools shall be required for this task.

**SRS** (PRTTDCIS-4456)

~~SRS-925~~ The Military SATCOM Terminal shall provide waveguide protection solutions that would prevent humidity inside the waveguides.

**SRS** (PRTTDCIS-4457)

~~SRS-926~~ Waveguides shall be sealed with RF conductive foils to prevent air ingress and ensure proper electric continuity.

**SRS** (PRTTDCIS-4458)

~~SRS-927~~ The Military SATCOM Terminal shall include sufficient quantities of mating connectors for all connectors, cables, and waveguides.

**SRS** (PRTTDCIS-4459)

~~SRS-928~~ The Contractor shall provide all the required information in order to have access authorization to a satellite, in case of need.

**SRS** (PRTTDCIS-2083)

~~SRS-929~~ The Military SATCOM Terminal shall withstand following additional wind specifications:

- Antenna deployed and terminal being operated with autotracking: 72 km/h (with gusts up to 95 km/h) with Maximum Pointing Loss of
  - 2 dB peak Ka Band; and,
  - 1.5 dB in X-Band; and,
- Antenna stowed: 161 km/h.

## 6.5 Combat Net Radio

**NOTE** (PRTTDCIS-2105)

~~[485]~~ The CNR belong to the proprietary PRC-525 ecosystem by EID which englobes the transceivers, power amplifiers, docking stations, remote consoles, etc.

**NOTE** (PRTTDCIS-2106)

~~[486]~~ The CNR support both voice and data in the xR security domain.

**NOTE** (PRTTDCIS-2107)

[187] The radios are installed in single or double Radio Docking stations that host one or two radios and its associated amplifier respectively.

**NOTE** (PRTTDCIS-2108)

[188] The rear link TR-525AH has a 500 W power amplifier associated.

**NOTE** (PRTTDCIS-1265)

[189] The MMA-xR RoIP integrator is the ICC-204 IP Intercom Systems model, which is PFE.

## 6.6 IP HF Radio

**NOTE** (PRTTDCIS-2100)

[190] The HF link data capability from the RL node operates as a Transmission System both for reach-back and intra-theatre links.

**NOTE** (PRTTDCIS-2101)

[191] The HF link is implemented by

- 1) The EID PRC-525 Combat Net Radio (CNR), supporting IP services and SIP client; and,
- 2) A Rohde & Schwarz VK4150 power amplifier together with the required Rohde & Schwarz IN4150 power source.

**NOTE** (PRTTDCIS-2102)

[192] The software used is the Rohde & Schwarz STANAG 5066.

**NOTE** (PRTTDCIS-2103)

[193] The expected IP service to be employed is e-mail (i.e. using the CFTP client of STANAG 5066).

## 7 Housing Elements

### 7.1 General

**NOTE** (PRTTDCIS-4508)

~~[494]~~ This section details the Housing Elements (e.g. Cases, Shelters, Trailers, etc.), their composing Elements and their ancillaries.

### 7.2 Common Elements

#### 7.2.1 Power Generator Unit

##### 7.2.1.1 General

**NOTE** (PRTTDCIS-3481)

~~[495]~~ This section contains all Power Generation Unit (PGU) specifications common to all DPOP PGU. Housing element specific (Shelter, Trailer...) PGU specifications are captured in the section dedicated to this specific housing element.

**NOTE** (PRTTDCIS-4526)

~~[496]~~ The PGU type is Design Driven. Should the TDCIS PGU be of DC type, PGU specifications specific to AC types are non-applicable.

**SRS** (PRTTDCIS-2168)

~~SRS-930~~ The PGU continuous rating shall be established for Voltage, Phase, Frequency and Speed at 230VAC, 50 Hz and 1500 to 1800rpm.

**SRS** (PRTTDCIS-2172)

~~SRS-931~~ The refueling port shall accept hose or canister refueling without mechanical obstacles.

**SRS** (PRTTDCIS-2174)

~~SRS-932~~ The PGU shall have a full diagnostic and control panel integrated with the LMM.

**SRS** (PRTTDCIS-2175)

~~SRS-933~~ The PGU shall be capable of being remotely controlled from the LMM.

**SRS** (PRTTDCIS-2176)

~~SRS-934~~ The PGU system noise level (dB) shall be  $\leq 57$  dB(A) at a distance of 7 meters in the outside of the shelter or inside the shelter (with the door closed) under full load.

**SRS** (PRTTDCIS-3043)

~~SRS-935~~ ONE (01) dedicated 6 kg portal ABC dry powder fire extinguishers Class ABC and suitable for fires involving electronic equipment up to 1000 V shall be located close to the Power Generator Unit (PGU) and mounted in such a manner that it is easily accessible from the ground.

**SRS** (PRTTDCIS-3147)

~~SRS-936~~ The PGU fire extinguisher shall meet requirements as stipulated in following standards:

- EN 3-7:2004+A1:2007 Portable fire extinguishers. Characteristics, performance requirements and test methods; and,
- EN 3-8:2006 Portable fire extinguishers. Additional requirements to EN 3-7 for the construction, resistance to pressure and mechanical tests for extinguishers with a maximum allowable pressure equal to or lower than 30 bar; and,
- EN 3-10:2009 Portable fire extinguishers. Provisions for evaluating the conformity of a portable fire extinguisher to EN 3-7.

**SRS** (PRTTDCIS-3337)

~~SRS-937~~ The PGU shall be designed and manufactured to comply with applicable European Union (EU) safety regulations, standards and requirements.

**SRS** (PRTTDCIS-3338)

~~SRS-938~~ The PGU shall meet the safety requirements as specified in ISO 8528-13:2016 Reciprocating internal combustion engine driven alternating current generating sets, Part 13: Safety

**SRS** (PRTTDCIS-3339)

~~SRS-939~~ PGU shall be designed and provided with equipment to meet requirements for power generators rated as Continuous Operating Power (COP) according to ISO 8528-1:2018.

**SRS** (PRTTDCIS-3340)

~~SRS-940~~ The PGU shall be able to provide continuous power on variable loads for minimum of 4000 hours per year.

**SRS** (PRTTDCIS-3341)

~~SRS-941~~ If the local power grid is available, the PGU shall be capable and equipped with necessary accessories to operate in standby mode, ready to manually activate, when necessary.

**SRS** (PRTTDCIS-3342)

~~SRS-942~~ The sound isolation shall be non-hydroscopic.

**SRS** (PRTTDCIS-3343)

~~SRS-943~~ The PGU enclosure shall be equipped with rodent barriers on inlets and outlets.

**SRS** (PRTTDCIS-3344)

~~SRS-944~~ The PGU enclosure shall be equipped with appropriate input and output soundproof louvers.

**SRS** (PRTTDCIS-3345)

~~SRS-945~~ The PGU shall be removable from the enclosure to support maintenance activities.

**SRS** (PRTTDCIS-3346)

~~SRS-946~~ The PGU integration shall not prevent the shelter to be washable with a nozzle.

**SRS** (PRTTDCIS-3347)

~~SRS-947~~ The PGU shall be mounted on oil resistant vibration isolation elements.

**SRS** (PRTTDCIS-3348)

~~SRS-948~~ The PGU enclosure shall be provided with internal LED lighting with micro-switches.

**SRS** (PRTTDCIS-3349)

~~SRS-949~~ The PGU enclosure lighting shall support the same modes as the shelter (Normal, Combat...).

**SRS** (PRTTDCIS-3352)

~~SRS-950~~ The enclosure shall be provided with inspection doors.

**SRS** (PRTTDCIS-3353)

~~SRS-951~~ The inspection doors shall be equipped with snap handles.

**SRS** (PRTTDCIS-3354)

~~SRS-952~~ The inspection doors shall be equipped with padlock.

**SRS** (PRTTDCIS-3355)

~~SRS-953~~ At least one of the inspection doors shall be provided with a document holder installed on the inside of the door.

**SRS** (PRTTDCIS-4659)

~~SRS-954~~ The document holder shall protect its content against any dirt (e.g. oil, fuel, etc.) and environmental conditions (e.g. humidity, temperature, dust, etc.)

**SRS** (PRTTDCIS-3356)

~~SRS-955~~ The PGU and all its components (Air filter, Oil filters...) shall be considered as an outdoor assembly for its environmental conditions compliance.

**SRS** (PRTTDCIS-3357)

~~SRS-956~~ The PGU shall be of compact type and easy to maintain.

**SRS** (PRTTDCIS-3358)

~~SRS-957~~ The PGU capacity is design driven. The Contractor shall design the PGU with a minimum of an additional 10% of capacity to accommodate future system expansion.

**SRS** (PRTTDCIS-3359)

~~SRS-958~~ The engine/generator assembly shall be a standard product of current manufacture, from one company regularly engaged in production of such equipment.

**SRS** (PRTTDCIS-3360)

~~SRS-959~~ The contractor shall provide engine manufacturer's recommended lubricants / coolants and data concerning their equivalents, including the manufacturer and supplier details.

**SRS** (PRTTDCIS-3361)

~~SRS-960~~ Operation angle for the PGU shall be minimum 20 degrees on any direction.

**SRS** (PRTTDCIS-3362)

~~SRS-961~~ An authorised technical surveillance authority, recognized by NATO, shall approve the mechanical and electrical safety. This includes the allowance for transport of the power generator on public roads, aircrafts, trains and ships.

**SRS** (PRTTDCIS-3363)

~~SRS-962~~ The PGU shall be supplied with CE mark and EC Declaration of Conformity in compliance with the Directive 2006/42/EC of the European Parliament and of the Council of 17 May 2006 on machinery, and amending Directive 95/16/EC.



**SRS** (PRTTDCIS-3364)

~~SRS-963~~ The PGU shall include at least following components:

- Electrical starter; and,
- Fuel meters to measure the net consumption of fuel by the engine in grams and liters. The meters shall have temperature correcting capability; and,
- Heavy-duty tube oil cooler with the temperature controlled by a thermostat valve; and,
- Lubricating oil pump; and,
- Fuel transfer pump; and,
- Radiator and belt-driven fan with mechanical protection, capable of cooling the engine on full load at all environmental conditions; and,
- Exhaust silencer; and,
- Oil pressure and temperature meters; and,
- Coolant temperature meter; and,
- Hot and moving parts protection; and,
- Anti-vibration, oil resistant shock absorbers; and,
- Reinforced lifting hooks for crane hoisting; and,
- Ground connection of electrical installation with ground spike; and,
- Digital diagnostic control panel; and,
- Supply and spill fuel-lines with fittings and fitted to the fuel tank; and,
- Exterior (piped to the edge of the enclosure) flexible oil and coolant drain lines with interior valves for ease of service; and,
- Fill of suitable lubricating oil, and anti-freeze for cooling system to assure performance at all environmental conditions.

**SRS** (PRTTDCIS-3365)

~~SRS-964~~ The PGU shall provide at least following functionalities:

- Safety shutdown system for low oil pressure, high temperature, over-speed and low fuel level with LED, re-settable indicators of the manual reset type; and,
- Dual fuel (fuel and fuel / water), oil and air filters in accordance with the manufacturer's specifications; and,
- Low oil pressure alarm; and,
- Over speed alarm; and,
- Low coolant level alarm; and,
- High coolant temperature alarm.

**SRS** (PRTTDCIS-3480)

~~SRS-965~~ PGU Lighting Protection and Grounding shall be integrated with those of the housing element hosting the PGU.

**SRS** (PRTTDCIS-3489)

~~SRS-966~~ PGU shall be provided with ONE (01) maintenance tool kit stored in a Stowage box, designed to restrict the entry of water and the tools shall be secured in place.

**SRS** (PRTTDCIS-3492)

~~SRS-967~~ Stowage Box shall be provided in the same colour as the PGU enclosure.

**SRS** (PRTTDCIS-3490)

~~SRS-968~~ PGU shall be provided with plate or plates (as required), located in convenient position without creating confusion with each other, imprinted on photosensitive anodized aluminium, conforming to type H, MIL-DTL 15024G, with a matt black background with following information printed:

- Operating instructions, emergency procedures, precautionary instructions to avoid personnel injury or equipment damage, servicing instruction, electrical schematics, technical characteristics, nomenclature and serial number; and,
- Centre of gravity marking with matt black colour; and,
- Information pertaining to air (as internal cargo-load and as helicopter external load), land, maritime and railways transportation.

**7.2.1.2 Engine****SRS** (PRTTDCIS-3366)

~~SRS-969~~ The engine shall be of a quick start, water-cooled industrial type.

**SRS** (PRTTDCIS-3367)

~~SRS-970~~ The engine shall be designed for continuous power rating.

**SRS** (PRTTDCIS-3368)

~~SRS-971~~ The engine shall be directly coupled to the synchronous electrical alternator.

**SRS** (PRTTDCIS-3369)

~~SRS-972~~ The engine power shall be such to drive the alternator at full load with power factor 0.8 lagging under all environmental conditions.

**SRS** (PRTTDCIS-3370)

~~SRS-973~~ The engine shall be capable of operating at light loads for extended periods of time and shall provide means to reduce carbonisation without requiring periodic cleaning of exhaust parts.

**SRS** (PRTTDCIS-3371)

~~SRS-974~~ The engine shall meet requirements for performance class G2 or better according to ISO 8528-2:2018 Reciprocating internal combustion engine driven alternating current generating sets, Part 2: Engines.

**SRS** (PRTTDCIS-3372)

~~SRS-975~~ De-rating due to extreme operating conditions and high altitude shall be addressed by the Contractor. However, the reduction of available power shall be less or equal than 3.5% per each 300m above 1200m of altitude.

**SRS** (PRTTDCIS-3373)

~~SRS-976~~ The declaration of power, fuel and lubricating oil consumption shall be determined in accordance with ISO 3046-1:2002 Reciprocating internal combustion engines, Performance, Part 1: Declarations of power, fuel and lubricating oil consumptions, and test methods, Additional requirements for engines for general use.

**SRS** (PRTTDCIS-3374)

~~SRS-977~~ The Specific fuel consumption and power output shall be quoted at standard (ISO) ambient conditions and at 45 degrees Celsius.

**SRS** (PRTTDCIS-3375)

~~SRS-978~~ The Contractor shall provide in technical documentation the de-rating curves or correction curves, formulae or calculations applicable to the generator for the power de-ration and fuel consumption for all environmental conditions.

**SRS** (PRTTDCIS-3376)

~~SRS-979~~ The engine shall be started electrically using batteries.

**SRS** (PRTTDCIS-3377)

~~SRS-980~~ The engine shall be equipped with a preheating system to keep the engine ready to start and take the full load, from 0 to 100%, within 15 seconds from standstill.

**SRS** (PRTTDCIS-3378)

~~SRS-981~~ The engine shall be multifuel ready and able to operate with at least the following fuels: diesel, DL-1, DL-2, JP-5 and JP-8.

**SRS** (PRTTDCIS-3379)

~~SRS-982~~ The PGU start system shall allow to be operated locally (directly on the next to the PGU) and remotely from inside the shelter (when PGU installed in a Shelter) and from the LMM.

**SRS** (PRTTDCIS-3380)

~~SRS-983~~ During each initial start of the engine, the PGU shall include a pre-lube at low idle speed system. When the internal oil pressure reaches the manufacturer predetermined safe value, the engine speed shall then increase to reach the alternator set operating speed.

**SRS** (PRTTDCIS-3381)

~~SRS-984~~ Convenient access for maintenance shall be assured. There shall be no need to remove the PGU from its enclosure to access coolant refill gauge, change oil and filters etc.

**SRS** (PRTTDCIS-3382)

~~SRS-985~~ Injection pumps and injection valves shall be of a type not requiring adjustment in service and shall be of a design allowing quick and field replacement by technicians without special diesel engine experience.

**SRS** (PRTTDCIS-3383)

~~SRS-986~~ The engines shall have an individual electronically controlled injection pump and injection valve for each cylinder, any one of which shall be removable and replaceable from stock parts.

**SRS** (PRTTDCIS-3384)

~~SRS-987~~ Fuel lines between injection pumps and valves shall be of heavy seamless tubing.

**SRS** (PRTTDCIS-3385)

~~SRS-988~~ Where applicable, air filters including pre-filters and dust traps shall be mounted in such a way to not to restrict the access to rocker covers and fuel injection pump.

**SRS** (PRTTDCIS-3386)

~~SRS-989~~ The oil sump shall preferably be equipped with a screw-in type stop that is easily accessible that drained oil can be caught in a vessel under the unit. If not possible, the oil sump shall include a cock with a pipe stopped by a mounted screw-on type stop. The pipe shall be long enough that drained oil can be caught in a vessel beside the unit. If the oil cannot be drained by gravity flow, the engine sump shall be equipped with a hand pump.

**SRS** (PRTTDCIS-3387)

~~SRS-990~~ The engine shall meet following characteristics:

- Engine Type: 4-stroke; and,
- Engine speed: 1500/1800 rpm; and,
- Insulation: H class or better; and,
- Protection: IP 23 or better according to IEC 60529: 1989/ AMD2: 2013/ COR1:2019.

### 7.2.1.3 Engine Cooling

**SRS** (PRTTDCIS-3388)

~~SRS-991~~ The engine cooling system shall be capable of adequately cooling the generator engine when it is supporting full load at the specified most extreme hot environmental conditions.

**SRS** (PRTTDCIS-3389)

~~SRS-992~~ The on-skid radiator cooling system shall be provided with the following:

- Water pumps for jacket water and turbocharger intercooler cooling complete with thermostatic bypasses; and,
- Water-air heat exchanger(s) for jacket water and turbocharger intercooler cooling complete with all necessary interconnection(s) to the on-board radiator; and,
- Automatic control of radiator fans, including automatic cycling for even running hours; and,
- Alarms and trip sensors for high/low coolant levels and temperatures.

**SRS** (PRTTDCIS-3390)

~~SRS-993~~ All cooling system components shall be monitored and alarmed by the control system.

**SRS** (PRTTDCIS-3391)

~~SRS-994~~ The cooling system shall include a heavy-duty, tropical-type radiator, constructed for high ambient/engine temperatures and withstanding all environmental conditions.

**SRS** (PRTTDCIS-3392)

~~SRS-995~~ The engine shall be provided with a thermostatic valve placed in the jacket water outlet between the engine and the cooling source.

**SRS** (PRTTDCIS-3393)

~~SRS-996~~ The thermostatic valve shall maintain the proper jacket water temperature under all load conditions.

**SRS** (PRTTDCIS-3394)

~~SRS-997~~ A flexible connecting section shall be provided between the radiator and discharge louver frame.

**SRS** (PRTTDCIS-3395)

~~SRS-998~~ The radiator shall be mounted on skid with oil resistant anti vibration mountings.

#### 7.2.1.4 Engine Heaters

**SRS** (PRTTDCIS-3396)

~~SRS-999~~ The engine shall be equipped with a thermostat controlled coolant immersion heater to aid engine starting, in most extreme cold environmental conditions.

**SRS** (PRTTDCIS-3397)

~~SRS-1000~~ The thermostat controlled coolant immersion heater shall be powered from the auxiliary power distribution

**SRS** (PRTTDCIS-3398)

~~SRS-1001~~ The heater shall be automatically switched off, when the engine is running.

### 7.2.1.5 Lubrication System

**SRS** (PRTTDCIS-3399)

~~SRS-1002~~ The lubrication system shall comprise an engine driven pump to circulate lubricating oil under pressure.

**SRS** (PRTTDCIS-3400)

~~SRS-1003~~ Full flow filters shall be provided together with replaceable elements.

**SRS** (PRTTDCIS-3401)

~~SRS-1004~~ Lube oil make-up shall be automatic monitored and alarmed by the control system.

**SRS** (PRTTDCIS-3402)

~~SRS-1005~~ The lubrication system shall be provided with alarms and trip sensors for high/low oil levels and temperatures and fitted with a crankcase heater if required.

### 7.2.1.6 Exhaust System

**SRS** (PRTTDCIS-3403)

~~SRS-1006~~ The engine exhaust system shall be composed of:

- 1) The exhaust silencer of a non-spark type, equipped with spark arrestor capable of the following:
  - 1) Low-pressure drop; and,
  - 2) Damping engine pulsations, backfiring and preventing any engine resonance; and,
  - 3) Sound attenuation as required to meet the noise level specified; and,
- 2) The discharge pipe work ; and,
- 3) Flanged flexible stainless steel thermal expansion bellows at the diesel engine exhaust outlet; and,
- 4) Support structures and fixings.

**SRS** (PRTTDCIS-3404)

~~SRS-1007~~ The exhaust shall be stainless steel

**SRS** (PRTTDCIS-3405)

~~SRS-1008~~ The exhaust shall be insulated as required.

**SRS** (PRTTDCIS-3406)

~~SRS-1009~~ The exhaust outlet shall be stainless steel provided with a mechanical closing valve.

**SRS** (PRTTDCIS-3407)

~~SRS-1010~~ The discharge stack and exhaust systems shall be supplied complete with roof, wall and floor mountings equipped with anti-vibration supports as required.

**SRS** (PRTTDCIS-3408)

~~SRS-1011~~ Noise control measures including splitter attenuators and acoustic linings shall be considered with regard to reducing the noise levels.

**SRS** (PRTTDCIS-3409)

~~SRS-1012~~ The complete exhaust system shall be designed such as not to exceed the noise limit of 65 dBA at a distance of about 7 meters from the output of the exhaust (in accordance with ISO 1996-1:2016) at full continuous load.

**SRS** (PRTTDCIS-3410)

~~SRS-1013~~ The silencer shall be connected to the set through an INOX (stainless steel) compensator.

**SRS** (PRTTDCIS-3411)

~~SRS-1014~~ Flanges shall help the pipes and the silencer to be easily disconnected.

**SRS** (PRTTDCIS-3412)

~~SRS-1015~~ Fixation of exhaust pipes and silencer shall take into account thermal expansion and vibration.

**SRS** (PRTTDCIS-3413)

~~SRS-1016~~ Purge valves shall be foreseen at the low points to evacuate any condensation.

**SRS** (PRTTDCIS-3414)

~~SRS-1017~~ Exhaust emission shall meet requirements as specified in Regulation (EU) 2016/1628 of the European Parliament and of the Council of 14 September 2016.

**SRS** (PRTTDCIS-3415)

~~SRS-1018~~ The fuel level emission shall be measured according to ISO 8178-4:2020 Reciprocating internal combustion engines, Exhaust emission measurement, Part 4: Steady-state and transient test cycles for different engine applications.

### 7.2.1.7 Insulation

#### SRS (PRTTDCIS-3416)

~~SRS-1019~~ The Contractor shall provide and install thermal insulation on the generator and supplied auxiliaries where required for the efficiency of the works, to meet regulatory requirements and safety of personnel.

#### SRS (PRTTDCIS-3417)

~~SRS-1020~~ All insulation materials shall not contain any asbestos or asbestos based products.

#### SRS (PRTTDCIS-3418)

~~SRS-1021~~ No part of the works that can be touched during normal operation shall have a surface temperature in excess of 50 degrees Celsius.

#### SRS (PRTTDCIS-3419)

~~SRS-1022~~ All insulation applied to pipe work, machinery, works, and ducting shall be clad with aluminium or stainless steel cladding of appropriate thickness not less than that conforming with BS 5970:2012 Thermal insulation of pipework, ductwork, associated equipment and other industrial installations in the temperature range of -100 degrees Celsius to +870 degrees Celsius, Code of practice.

#### SRS (PRTTDCIS-3420)

~~SRS-1023~~ All insulation exposed to the weather shall be sufficiently clad to be completely weatherproof.

#### SRS (PRTTDCIS-3421)

~~SRS-1024~~ Insulation and cladding shall be designed and applied with proper allowance for expansion and contraction.



### 7.2.1.8 Fuel Supply

#### SRS (PRTTDCIS-3430)

~~SRS-1025~~ The tank shall be provided with the necessary equipment to supply the generator with fuel and as a minimum shall include the following:

- A fuel level indicator; and,
- A pump with in and out pressure gauges and automatic and manual ON/OFF operation; and,
- Low and high level alarms (sound alarms shall be capable of being disabled for tactical reasons) ; and,
- An auxiliary hand pump and associated manual valves; and,
- A fuel strainer on supply pump inlet with water separator; and,
- A vent cap; and,
- A drain valve with locking handle; and,
- Engine return pipes; and,
- A fuel leak detector; and,
- A fuel consumption meter.

#### SRS (PRTTDCIS-3429)

~~SRS-1026~~ The fuel supply system shall be equipped with an automatic stop system due to lack of fuel.

#### SRS (PRTTDCIS-3428)

~~SRS-1027~~ A de-fueling system shall be provided to meet commercial and military air transport regulations.

#### SRS (PRTTDCIS-3427)

~~SRS-1028~~ Refilling by hand from jerry cans or locally from a mobile tank with electric pump shall be possible during operation of the PGU.

#### SRS (PRTTDCIS-3426)

~~SRS-1029~~ The fuel inlet cap shall be secured with a padlock.

#### SRS (PRTTDCIS-3425)

~~SRS-1030~~ External fuel inlet with warning light for full tank shall be provided with lockable cap.

#### SRS (PRTTDCIS-3424)

~~SRS-1031~~ The PGU Fuel Tank shall be reinforced with non-cutting edge bulkheads.

#### SRS (PRTTDCIS-3423)

~~SRS-1032~~ The PGU Fuel tank shall be compliant with the latest European Safety Regulations.

**SRS** (PRTTDCIS-3422)

~~SRS-1033~~ PGU shall be provided with an integrated Fuel Tank, housed inside the PGS enclosure, of the capacity assuring at least 12 hours continuous operation under rated continuous power.

**7.2.1.9 Alternator****SRS** (PRTTDCIS-3431)

~~SRS-1034~~ The alternator shall be a synchronous, regulated, drip proof industrial type.

**SRS** (PRTTDCIS-3432)

~~SRS-1035~~ The alternator shall be self-excited of a rotating field brushless design.

**SRS** (PRTTDCIS-3433)

~~SRS-1036~~ The alternator shall be provided with sealed-for-life bearings.

**SRS** (PRTTDCIS-3434)

~~SRS-1037~~ The alternator shall be rated for a nominal continuous output and overload capacity at the specified environmental conditions

**SRS** (PRTTDCIS-3435)

~~SRS-1038~~ The alternator shall be capable of delivering rated output (kVA) at rated frequency and power factor, at any voltage not more than 5 per cent above or below rated voltage.

**SRS** (PRTTDCIS-3436)

~~SRS-1039~~ The instantaneous voltage dip shall not exceed 20% of rated voltage when full load, at rated power factor, is suddenly applied.

**SRS** (PRTTDCIS-3437)

~~SRS-1040~~ Recovery of stable operation shall occur within 5 seconds. Steady state modulation shall not exceed +0.5%.

**SRS** (PRTTDCIS-3438)

~~SRS-1041~~ Alternator windings shall be braced for full line ground fault currents, with solidly grounded neutral system.

**SRS** (PRTTDCIS-3439)

~~SRS-1042~~ The alternator output shall be wired to heavy-duty terminations, via an appropriately rated, moulded case circuit breaker, with overload and short circuit protection.

**SRS** (PRTTDCIS-3440)

~~SRS-1043~~ The insulation to windings shall have an oil, moisture, salt air, fungus proof finish and epoxy coated with surface which will not retain dust or condensation.

**SRS** (PRTTDCIS-3441)

~~SRS-1044~~ It shall be possible to put the set in service after long periods in unheated storage without the necessity for drying up insulation.

**SRS** (PRTTDCIS-3442)

~~SRS-1045~~ The winding insulation shall be minimum Class H according to IEC 60085:2007 Electrical insulation - Thermal evaluation and designation.

**SRS** (PRTTDCIS-3443)

~~SRS-1046~~ The exciter shall be a fast response type, with a rotating full-wave bridge.

**SRS** (PRTTDCIS-3444)

~~SRS-1047~~ The exciter shall have a low time constant and large capacity to minimize voltage transients under severe load changes.

**SRS** (PRTTDCIS-3445)

~~SRS-1048~~ The alternator shall be controlled by a digital Automatic Voltage Regulator (AVR).

**SRS** (PRTTDCIS-3446)

~~SRS-1049~~ The regulator shall include phase voltage sensing, automatic short circuit protection and shall include automatic under frequency protection to allow the generator to operate at no load at less than synchronous speed for engine start-up and shutdown procedures.

**SRS** (PRTTDCIS-3447)

~~SRS-1050~~ The AVR shall be capable of maintaining voltage between +1.0% and -1.0% of any value within 10% of the nominal voltage throughout the full range of rated load and power factor conditions.

**SRS** (PRTTDCIS-3448)

~~SRS-1051~~ Droop, stability and voltage set point adjustments shall be done by operator interface.

**SRS** (PRTTDCIS-3449)

~~SRS-1052~~ The AVR shall be capable of preventing sustained over voltage during over speed conditions following the loss of load.

**SRS** (PRTTDCIS-3450)

~~SRS-1053~~ After a sudden load rejection at rated power factor, rated voltage shall be restored within 2 seconds.

**SRS** (PRTTDCIS-3451)

~~SRS-1054~~ Controls shall be provided to monitor the output current of the generator set and initiate an alarm (over current warning) when load current exceed 110% of the rated current of the generator set on any phase for more than 60 seconds.

**SRS** (PRTTDCIS-3452)

~~SRS-1055~~ The controls shall shut down and lock out the generator set when output current level approaches the thermal damage point of the alternator (over current shutdown).

**SRS** (PRTTDCIS-3453)

~~SRS-1056~~ Controls shall be provided to individually monitor phases of the output for short circuit conditions.

**SRS** (PRTTDCIS-3454)

~~SRS-1057~~ The control/protection system shall monitor the current level and voltage.

**SRS** (PRTTDCIS-3455)

~~SRS-1058~~ The controls shall shut down and lock out the generator set when output current level approaches the thermal damage point of the alternator (short circuit shutdown).

**SRS** (PRTTDCIS-3456)

~~SRS-1059~~ Controls shall be provided to monitor the kW load on the generator set, and initiate an alarm condition (overload) when total load on the generator set exceeds the generator set rating for in excess of 5 seconds.

**SRS** (PRTTDCIS-3457)

~~SRS-1060~~ All software, programming leads and software dongles and the like shall be provided if a computer programmable system is offered.

**SRS** (PRTTDCIS-3458)

**SRS-1061** The excitation system shall include the following features and facilities as the minimum:

- Voltage setting control; and,
- Power factor control; and,
- Protection against AVR failures (e.g. over/under excitation combined with over/under voltage) ; and,
- Supervised fault detection; and,
- An excitation system which will withstand short circuits and synchronising of the machine up to 90 degree out of phase without failure of the components; and,
- A brushless excitation system.

**SRS** (PRTTDCIS-3459)

**SRS-1062** The alternator shall have following characteristics:

- Nominal Voltage: 230VAC, single phase; and,
- Nominal frequency: 50 Hz; and,
- Rated output: to be determined by the Contractor; and,
- Power factor: 0.8 lagging; and,
- Efficiency: min 90% at power factor 0.8 lagging.

**7.2.1.10 Coupling****SRS** (PRTTDCIS-3460)

**SRS-1063** The elastic coupling between the engine and the alternator shall be such as to prevent abnormal wear and overheating of the bearings due to slight misalignment within the specified tolerances.

**SRS** (PRTTDCIS-3461)

**SRS-1064** Any part of the elastic coupling subject to wear shall be easily accessible for inspection and replacement.

**7.2.1.11 Engine Starting System****SRS** (PRTTDCIS-3462)

**SRS-1065** The engine shall be provided with an on-skid dual 12/24 VDC electric starting system.

**SRS** (PRTTDCIS-3463)

~~SRS-1066~~ The engine starting system, as the minimum shall be composed of:

- The electric starting motors; and,
- Low maintenance starting batteries; and,
- Ventilated battery housing; and,
- Vibration-free battery rack/tray; and,
- Interconnection cables; and,
- 230VAC battery chargers.

**SRS** (PRTTDCIS-3464)

~~SRS-1067~~ The battery chargers shall be capable of re-charging the batteries to full potential within one hour after a cranking cycle and shall be adjustable to compensate for the battery self-discharge rate during standby periods.

**SRS** (PRTTDCIS-3465)

~~SRS-1068~~ The starting batteries shall be lead acid, maintenance free type with a minimum of 5 years expected life time.

**SRS** (PRTTDCIS-3466)

~~SRS-1069~~ The batteries and starters shall be capable of TEN (10) starts per hour with a minimum of 5 consecutive start attempts.

**SRS** (PRTTDCIS-3467)

~~SRS-1070~~ All battery system components shall be monitored and alarmed by the control system.

**SRS** (PRTTDCIS-3468)

~~SRS-1071~~ The control system provided shall include a cycle cranking system, which allows for user selected crank time, rest time, and number of cycles. Initial settings shall be for 3 cranking periods of 15 seconds each, with 15 second rest period between cranking periods.

**SRS** (PRTTDCIS-3469)

~~SRS-1072~~ The control system shall include time delay start (adjustable from 0 to 300 seconds) and time delay stop (adjustable from 0 to 600 seconds) functions.

**SRS** (PRTTDCIS-3470)

~~SRS-1073~~ Lockable battery isolator switch shall be provided for use during maintenance and storage.

### 7.2.1.12 Digital Diagnosis Control Panel

**SRS** (PRTTDCIS-3471)

~~SRS-1074~~ The digital Diagnostic Control Panel shall be mounted on the power generator in such a way that it would allow monitoring of basic parameters through a visor without opening any doors or flaps.

**SRS** (PRTTDCIS-3472)

~~SRS-1075~~ The digital Diagnostic Control Panel shall be behind door mounted.

**SRS** (PRTTDCIS-4660)

~~SRS-1076~~ The PGU shall include a secondary detachable Digital Diagnostic Control Panel and cable remotable to a minimum distance of 25m from the PGU to the Sys Admin Tent.

**SRS** (PRTTDCIS-4661)

~~SRS-1077~~ The detachable Digital Diagnostic Control Panel shall provide the same functionalities as the PGU Digital Diagnostic Control Panel.

**SRS** (PRTTDCIS-3473)

~~SRS-1078~~ The digital Diagnostic Control Panel visor shall be secured with padlock, tampered and weatherproof.

**SRS** (PRTTDCIS-3474)

**SRS-1079** The digital Diagnostic Control Panel shall contain as the minimum:

- 1) The static battery charger; and,
- 2) The starting procedure; and,
- 3) The command equipment:
  - 1) One 3 position switch: OFF-AUTO-MANUAL; and,
  - 2) Two push-buttons: START - STOP for use in manual position; and,
  - 3) One emergency stop push-button; and,
  - 4) A push button to stop the audible alarm; and,
  - 5) An alarm reset push-button; and,
  - 6) An alarm lamp test button; and,
  - 7) A button to select the enclosure lighting mode; and,
- 4) A Command & Control system able to show the following information:
  - 1) Generator load; and,
  - 2) Generator voltage; and,
  - 3) Generator current; and,
  - 4) DC battery voltage; and,
  - 5) DC battery current; and,
  - 6) Running time meter (engine hour counter); and,
  - 7) Frequency; and,
  - 8) Oil pressure; and,
  - 9) Oil temperature; and,
  - 10) Coolant temperature; and,
  - 11) Engine speed (rpm) ; and,
  - 12) Status indicator for the alarms; and,
  - 13) Audible alarm (10 dB over generator noise) ; and,
- 5) The following displayed digital information and alarms:
  - 1) Coolant high temperature; and,
  - 2) Oil high temperature; and,
  - 3) Low oil pressure; and,
  - 4) High oil pressure; and,
  - 5) Missed start; and,
  - 6) Battery charger failure; and,
  - 7) Over speed; and,
  - 8) Under speed; and,
  - 9) Over voltage; and,
  - 10) Under voltage; and,
  - 11) Low fuel tank level; and,
  - 12) AVE alarms.

**SRS** (PRTTDCIS-3475)

**SRS-1080** In case of an alarms occurs, the following sequence shall be followed:

- 1) The corresponding alarm appears on the control panel and the audible alarm is activated; and,
- 2) The audible alarm is stopped by means of the related push-button; and,
- 3) After the audible alarm is stopped the visual alarm stays on; and,
- 4) The visual alarm disappears after activation of the reset push-button.



**SRS** (PRTTDCIS-3476)

~~SRS-1081~~ The Emergency stop push-button shall be a mushroom type push button, red colour.

**SRS** (PRTTDCIS-3477)

~~SRS-1082~~ The Emergency stop push-button shall be protected to prevent inadvertent operation.

**SRS** (PRTTDCIS-3478)

~~SRS-1083~~ The Emergency stop push-button activation shall be possible without opening any panels, flaps, doors or any other type of covers with easy access and no obstructions.

**SRS** (PRTTDCIS-3479)

~~SRS-1084~~ The Emergency stop push-button shall be in conformity with the requirements of following directives and standards: MD 2006/42/EC, LVD 2014/35/EU, IEC 60947-5-1:2016, IEC 60204-1:2016, ISO 13849-1:2015, and IEC 60947-5-5:1997 + AMD1: 2005 +AMD2:2016 CSV.

### 7.2.1.13 Circuit Breakers

**SRS** (PRTTDCIS-3482)

~~SRS-1085~~ Main line, moulded case circuit breaker mounted upon and sized to the output of the generator at 50 Hz shall be installed as a load circuit interrupting and protection device.

**SRS** (PRTTDCIS-3483)

~~SRS-1086~~ It shall operate both manually for normal switching functions and automatically during failure events.

**SRS** (PRTTDCIS-3484)

~~SRS-1087~~ The breaker shall also include ground fault sensing that will trip the breaker on ground fault conditions.

**SRS** (PRTTDCIS-3485)

~~SRS-1088~~ The circuit breakers on the generator power supply outlet shall be covered by flex glass internally and externally for protection against electrical hazards.

**SRS** (PRTTDCIS-3486)

~~SRS-1089~~ The circuit breakers shall be complaint with IEC 60947:2021 series and with IEC 60898.

#### 7.2.1.14 Fuel Jerry Cans

##### **SRS** (PRTTDCIS-2446)

~~SRS-1090~~ Jerry Cans (portable petrol storage containers) shall meet the performance requirements for the carriage of petrol under the European Agreement Concerning the International Carriage of Dangerous Goods by Road (ADR).

##### **SRS** (PRTTDCIS-3202)

~~SRS-1091~~ Jerry Can shall be made of metal (steel sheet or aluminium) with nominal capacity of 20 liters each.

##### **NOTE** (PRTTDCIS-3203)

~~[197]~~ The nominal capacity of the container is the maximum volume of liquid the container is intended to hold at 20 degrees Celsius.

##### **SRS** (PRTTDCIS-3204)

~~SRS-1092~~ The total capacity of Jerry Can shall be between 10% and 15% more than the nominal capacity (i.e. the maximum volume of liquid that the container would hold if filled to the brim).

##### **SRS** (PRTTDCIS-3205)

~~SRS-1093~~ The lids or tops shall be well-fitting and made of suitable material to remain secure and prevent the escape or leakage of liquid or vapor, with the closure providing an effective seal at all times when applied.

##### **SRS** (PRTTDCIS-3206)

~~SRS-1094~~ The closure shall not show any visible signs of leaking even if the container is on its side or accidentally tipped over.

##### **SRS** (PRTTDCIS-3207)

~~SRS-1095~~ Any opening for filling shall allow for the safe filing of petrol from a petrol pump without using a funnel.

##### **SRS** (PRTTDCIS-3209)

~~SRS-1096~~ Any opening shall allow for the safe filing of the PGU without using a funnel.

##### **SRS** (PRTTDCIS-3210)

~~SRS-1097~~ Jerry Can shall be delivered with a Petroleum, Oil and Lubricant (POL) compliant foldable bucket to be used when the Jerry can is put on the ground and avoid any potential fuel leak to be release in the environment.

**SRS** (PRTTDCIS-3211)

~~SRS-1098~~ Jerry Can shall be marked or labelled in a legible and indelible form with:

- the words 'PETROL' and 'HIGHLY FLAMMABLE'; and,
- an appropriate hazard warning sign; and,
- the nominal capacity in liters; and,
- the manufacturer's name and the date and month of manufacture.

**SRS** (PRTTDCIS-3491)

~~SRS-1099~~ Jerry Cans shall be provided in the same colour as the PGU enclosure.

## 7.2.2 Uninterruptible Power Supply

**SRS** (PRTTDCIS-4504)

~~SRS-1100~~ The UPS shall include a visual alarm, an audio alarm and a contact closure loop to inform locally and remotely loss of mains power and of low battery power to ensure the timely implementation of the graceful shutdown processes and procedures.

**SRS** (PRTTDCIS-4505)

~~SRS-1101~~ As a minimum, the following commands and control operations of the UPS shall be possible and accessible right after the removal of the UPS case lid which protects the UPS unit during transportation, storage and handling:

- 1) System OFF; and,
- 2) System on UPS; and,
- 3) System on Static Bypass; and,
- 4) System on Manual Bypass; and,
- 5) Alarm silence switch; and,
- 6) Measurement of:
  - 1) Input current; and,
  - 2) Input voltage; and,
  - 3) Input power; and,
  - 4) DC voltage; and,
  - 5) DC current; and,
  - 6) Output voltage; and,
  - 7) Output current; and,
  - 8) Output frequency; and,
  - 9) Output power; and,
- 7) As a minimum, visual and audible alarms:
  - 1) Battery at low level and low voltage; and,
  - 2) System on bypass; and,
  - 3) Input supply failure; and,
  - 4) Overload; and,
  - 5) High temperature; and,
  - 6) UPS not answering or communication lost; and,
  - 7) Logging of previous minimum 50 alarms shall be possible; and,
- 8) Automatic battery check-up.

**SRS** (PRTTDCIS-4506)

~~SRS-1102~~ The UPS shall signal changes in status towards the LMM, as well as critical capacity warnings and visual and audio indications from the UPS itself.

**SRS** (PRTTDCIS-4507)

~~SRS-1103~~ The UPS shall support the triggering of a graceful shutdown mechanism of the Elements it power supplies.

## 7.2.3 Cable Reels

### 7.2.3.1 General

**NOTE** (PRTTDCIS-4396)

~~[198]~~ This section contains all Cable Reels specifications common to all DPOP Elements including those. Element specific (e.g. Shelter, Trailer, etc.) Cable Reels specifications are captured in the section dedicated to this specific element.

**SRS** (PRTTDCIS-3335)

~~SRS-1104~~ All cable reels (Electrical, FO, SFTP, etc.) shall meet following characteristics:

- Heavy duty, ruggedized for field military applications; and,
- Painted with the same colour (or black) and type of painting as the shelter; and,
- Roll-formed channel frame for heavy-duty applications; and,
- Non-sparking ratchet assembly; and,
- Declutching arbour to prevent damage from reverse winding; and,
- Fold-in swivel handles; and,
- Lightweight aluminium structure with protecting frame; and,
- Easy access to the inner end; and,
- Fixings to secure cable ends for transport, handling and storage.

**SRS** (PRTTDCIS-2161)

~~SRS-1105~~ Cable Reels shall be painted in RAL 840R 6014, non-gloss or equivalent.

**SRS** (PRTTDCIS-2160)

~~SRS-1106~~ The cable shall be mounted on a mobile drum with belt strap and drum locking system.

**SRS** (PRTTDCIS-3031)

~~SRS-1107~~ Each cable reel shall include a cable retention system on both ends to protect connectors from traction.

**SRS** (PRTTDCIS-3034)

~~SRS-1108~~ The Cable Reel shall include handle to be carried by hand.

**SRS** (PRTTDCIS-4662)

~~SRS-1109~~ Each Shelter shall include ONE (01) Cable Reel Backpack Harness able to attach ONE (01) Cable reel.

### 7.2.3.2 FO Cable Reels

**SRS** (PRTTDCIS-2159)

~~SRS-1110~~ The FO Cable Reel shall contain a 250 m long, black color, FO cord suitable for tactical use with mating connectors to the ECP.

### 7.2.3.3 SFTP Cable Reels

**SRS** (PRTTDCIS-2162)

~~SRS-1111~~ The SFTP Cable Reel shall contain FOUR (04) 50 m long, black color, Cat. 6 or better SFTP cables suitable for tactical use with matting connectors to the ECP.

### 7.2.3.4 WD-1/TT Cable Reels

**SRS** (PRTTDCIS-4663)

~~SRS-1112~~ The WD-1/TT Cable Reel shall contain ONE (01) 1500 m long WD-1/TT 2-wires PFE cable.

## 7.3 Shelter

### 7.3.1 General

**SRS** (PRTTDCIS-1372)

~~SRS-1113~~ The Shelter is the housing element for all CIS and non-CIS assets that constitute a node. Following figure illustrates the Shelter breakdown structure. It identifies the elements it is composed of. Each Shelter shall be built upon the building blocks as identified in this reference.

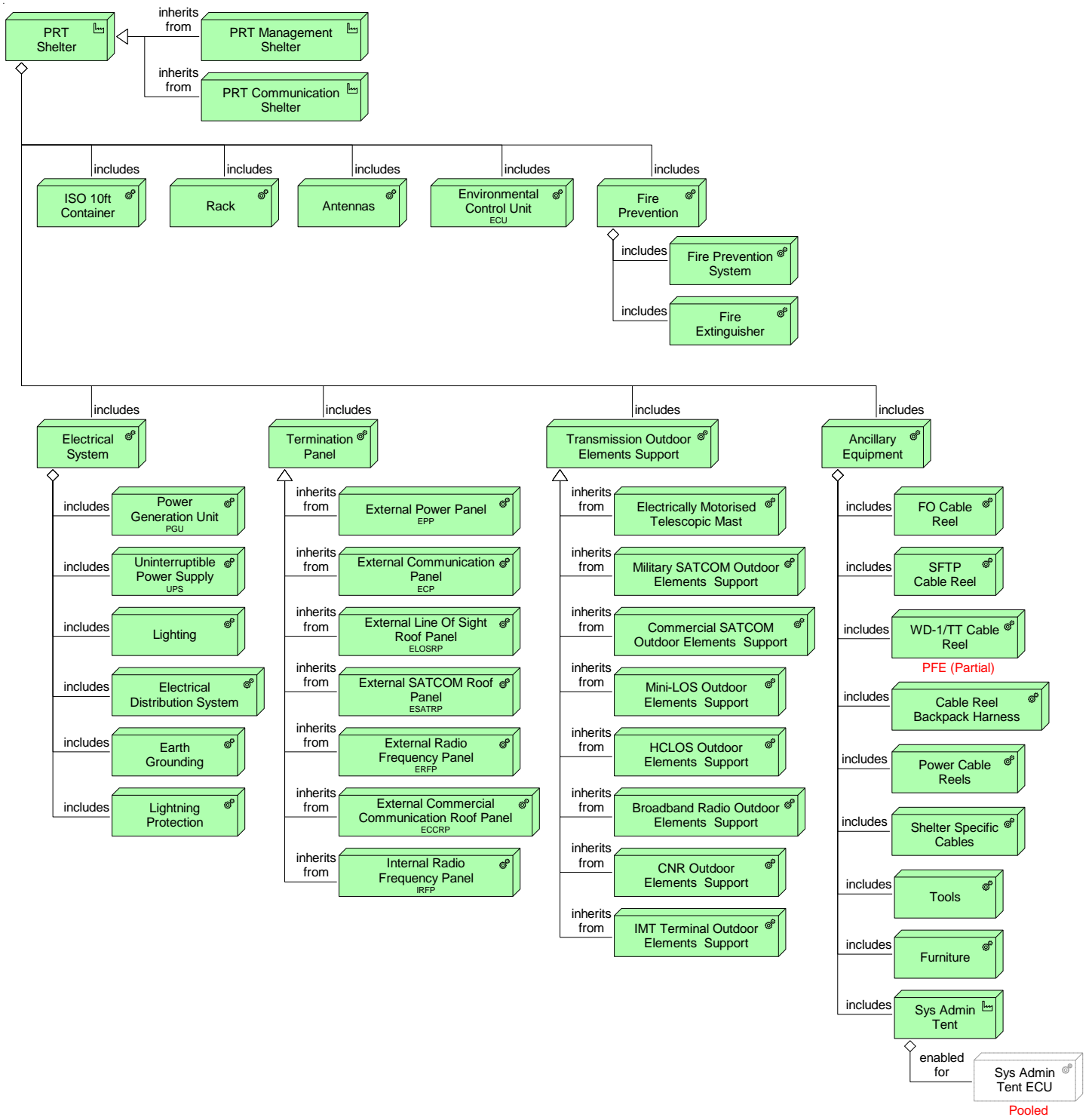

Figure 85 - Shelter Breakdown Structure

**SRS (PRTTDCIS-1241)**

**SRS-1114** To achieve better maintainability and supportability, all Shelters shall be designed and built the same and share a common baseline to support any Node configuration.

**SRS** (PRTTDCIS-1375)

~~SRS-1115~~ All Shelters shall have a common base consisting of:

- Structure; (i.e. Container, racks, cabling, etc.); and,
- Electrical Power; and,
- Environmental Control Unit; and,
- External Termination Boards; and,
- Satellite and Antenna Masts Supports; and,
- Ancillary Equipment.

**SRS** (PRTTDCIS-1374)

~~SRS-1116~~ The node-configured Shelter common base shall only be fitted with those Module and Transmission Systems Elements required for the specific nodal functionalities and services.

**SRS** (PRTTDCIS-4528)

~~SRS-1117~~ Only Shelters implementing Nodes equipped with Military SATCOM Terminal and implementing Nodes marked as Enabled for Military SATCOM Terminal, shall include the Military SATCOM Terminal Installation Kit (IK) (e.g. mechanical interfaces, cabling, rack space, ESATRP, etc.).

**NOTE** (PRTTDCIS-2111)

~~[199]~~ TDCIS Nodes are composed of one or two shelters. When a statement refers to the Node Shelter, it refers to all shelters composing the node, without any consideration for quantities.

**SRS** (PRTTDCIS-1369)

~~SRS-1118~~ The interior surfaces of shelters shall be painted white in accordance with the colour standard mat paint RAL 9010.

**SRS** (PRTTDCIS-2467)

~~SRS-1119~~ Shelters outdoor surfaces shall be painted with Infra-Red Reflective (IRR) properties, permitting a subsequent application of a top coat with Chemical Agent Resistant Coating (CARC) characteristics, in accordance with Def Stan 80-208 (Issue 3, Amend. 1) and Def Stan 80-215 (Issue 2)

**SRS** (PRTTDCIS-1376)

~~SRS-1120~~ The shelter shall be capable of being transported on a wheeled 4x4 Medium Tactical Vehicle (MTV) procured by the Portuguese Army, which is designed to transport a 10ft ISO container.

**NOTE** (PRTTDCIS-4544)

~~[200]~~ The MTV will include stabilization legs.

**SRS** (PRTTDCIS-1377)

~~SRS-1124~~ All node-configured shelter, when dismantled from the MTV, shall be capable of being transported within a suitable military aircraft (e.g. C-130H, KC-390) currently in service with the Portuguese Army.

**SRS** (PRTTDCIS-1378)

~~SRS-1122~~ The shelter shall be designed to be lifted and transported, when installed with all necessary elements, by the following means:

- Forklift (from each of its longer sides); and,
- Crane; and,
- Helicopter.

**SRS** (PRTTDCIS-1379)

~~SRS-1123~~ A shelter total gross weight, in any Node variant, fully equipped and ready for transport, shall not exceed 3500 kilograms.

**NOTE** (PRTTDCIS-3544)

~~[204]~~ The Contractor will aim for all node-configured shelter variants to be the lighter possible.

**NOTE** (PRTTDCIS-3197)

~~[202]~~ Shelter will not include a camouflage net and will benefit from the Vehicle Camouflage Net.

**SRS** (PRTTDCIS-4532)

~~SRS-1124~~ Each shelter shall include a temporary sitting position where a system administrator can take place and use its workstation when performing activities inside the shelter. This temporary working position shall be supported by a wall mounted foldable table.

**SRS** (PRTTDCIS-1813)

~~SRS-1125~~ Unless stated otherwise, all Node elements (e.g. UAM, HCLOS, Mini-LOS, System Administrator EUD, etc.) shall be fixed and stored in the Shelter (inside or in accommodations installed in the allocable area) for storage and transportation.

## 7.3.2 Structure

### 7.3.2.1 General

**SRS** (PRTTDCIS-3144)

~~SRS-1126~~ The Shelter shall be designed in accordance with and certified compliant to: 6516/SHCPE/86-88.



**SRS** (PRTTDCIS-1380)

~~SRS-1127~~ The shelter shall be constructed based on ASTM E1925.

**SRS** (PRTTDCIS-2112)

~~SRS-1128~~ The shelter wall, ceiling and floor panels shall have a "sandwich structure" (as per 6516/SHCPE/86-88) while remaining compliant with ISO 1496.

**SRS** (PRTTDCIS-1381)

~~SRS-1129~~ The shelter shall support "ISO corner" mounting in accordance with ISO 1161:2016.

**SRS** (PRTTDCIS-1382)

~~SRS-1130~~ The shelter external floor base dimensions shall adhere to the ISO 10 feet container type structure in accordance with ISO 668:2013 (i.e. L 10ft x W 8ft).

**SRS** (PRTTDCIS-1387)

**SRS-1134** The shelter, when ready for transportation (i.e. not deployed), and all its attached parts (e.g. masts, antenna, etc.) shall not protrude outside of the "free area" envelope:

- Laterally, all parts shall be within the external 8ft width limit of an ISO 10ft container; and,
- Longitudinally, attached parts may protrude up to 976 mm (3.2ft) in the front and in the aft of the shelter with a maximum length of a shelter, including protruding parts, shall be 16.4ft (approx. 5m); and,
- Vertically, all parts shall be within the maximum external height of 8ft 6in.

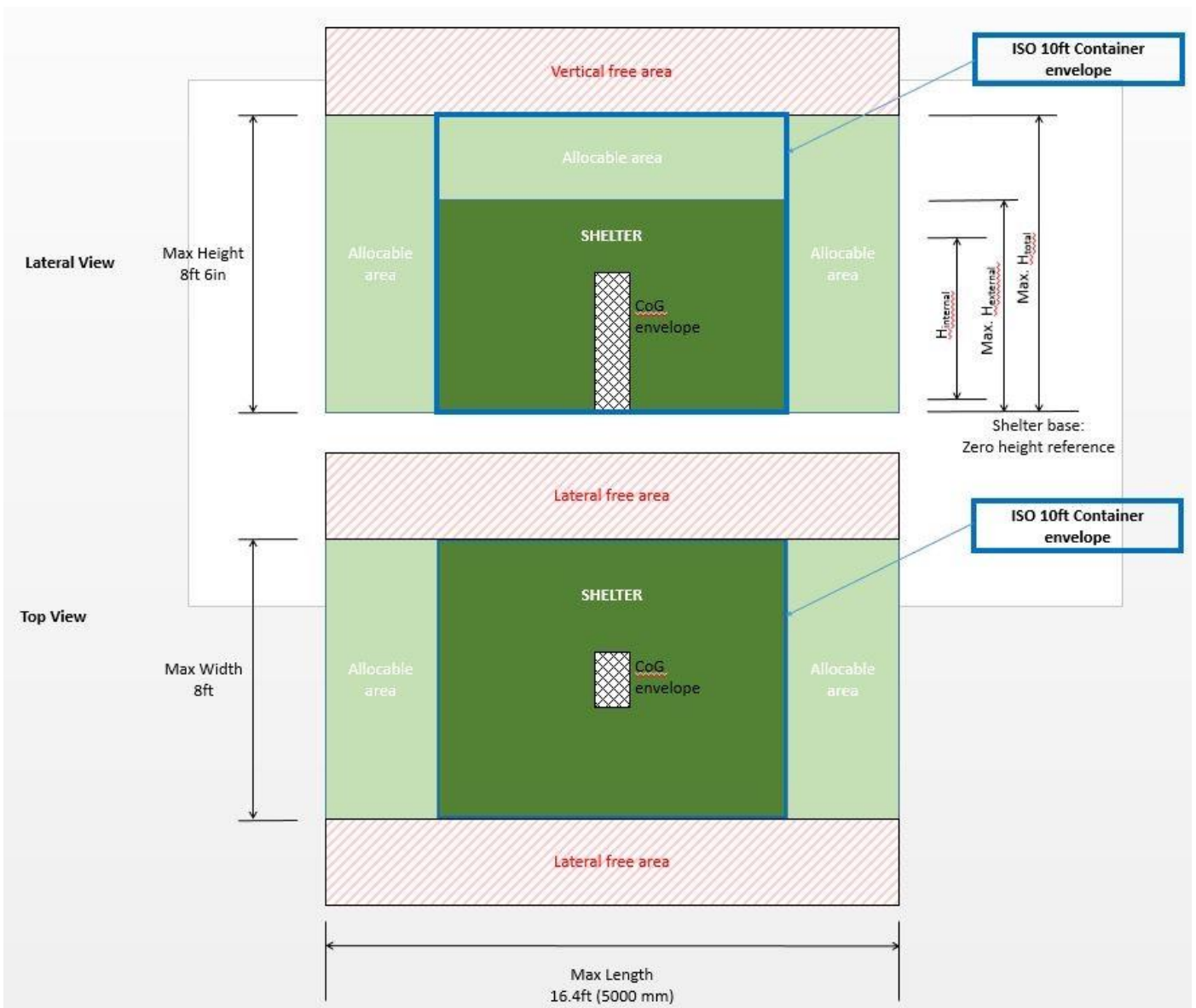

Figure 86 - Shelter Mechanical Envelope

**NOTE** (PRTTDCIS-2114)

[203] Note that when the shelter is operationally deployed, the above specified envelopes are not applicable.

**SRS** (PRTTDCIS-1383)

~~SRS-1132~~ The maximum external height of the shelter (for all possible shelter configurations) excluding all roof mounted ancillary equipment (e.g. foldable satellite dish) shall not exceed 2000 mm.

**SRS** (PRTTDCIS-2113)

~~SRS-1133~~ The maximum external envelope height of the shelter (for all possible Node variant) in transport mode including all roof mounted ancillary equipment (e.g. foldable satellite dish) shall not exceed 8ft 6in (i.e. 2590.8mm).

**SRS** (PRTTDCIS-1384)

~~SRS-1134~~ The shelter minimum internal height when measured from the floor to ceiling shall be 1750mm.

**SRS** (PRTTDCIS-1385)

~~SRS-1135~~ The shelter external vertical height zero reference measurement point shall be considered the bottom of the shelter base.

**SRS** (PRTTDCIS-1386)

~~SRS-1136~~ Fully loaded shelter shall have the Center of Gravity (CoG) within the envelope as specified below (extracted from ISO 8323:1985):

- +/- 10% of the external width, measured from the geometric center; and,
- +/- 5% of the external length, measured from the geometric center; and,
- Below a height of 1219 mm (4ft = half height of an ISO 10ft container), measured from the bottom of the base.

**NOTE** (PRTTDCIS-1388)

[204] The shelter accessories will preferably be located within the lateral fore and lateral aft areas.

**NOTE** (PRTTDCIS-2115)

[205] The shelter accessories will preferably not be located on the top of the shelter.

**SRS** (PRTTDCIS-1389)

~~SRS-1137~~ The shelter walls shall be mechanically robust to support input/output panels and anchorage points for the attachment of equipment racking systems and accessories.

**SRS** (PRTTDCIS-1392)

~~SRS-1138~~ The shelter internal wall structure, floor and ceiling shall implement NATO C-profile railing (as per 6516/SHCPE/86-88) to support the attachment and installation of equipment, railing and ancillary items, etc. to be installed inside the shelter.

**SRS** (PRTTDCIS-1395)

~~SRS-1139~~ The shelter back wall shall have a door for easy access of personnel and equipment to the shelter interior. The door shall:

- Support a 6 point locking mechanism; and,
- Support an opening system operable from the outside and inside; and,
- It shall be possible to open the door from the inside in 3 seconds, even when closed from the outside; and,
- Have the maximum possible height possible, depending on the overall height of the shelter and a width between 800 mm and 860 mm; and,
- Have a locking device (e.g. padlock, with min 4 digit security code).

**7.3.2.2 Roof****SRS** (PRTTDCIS-1390)

~~SRS-1140~~ The shelter external roof panel shall be mechanically robust and covered with an "anti-slip" to support the presence and movement of military personnel.

**SRS** (PRTTDCIS-3125)

~~SRS-1141~~ The "anti-slip" coating shall meet requirements as stipulated in STANAG 4698, Edition 1 and its associated AEP-63, Edition 1: Performance requirements for non-skid coating systems.

**SRS** (PRTTDCIS-3126)

~~SRS-1142~~ The shelter roof assembly shall be able to withstand a static load of 300 kg/m<sup>2</sup>.

**SRS** (PRTTDCIS-3127)

~~SRS-1143~~ The shelter roof assembly shall allow for personnel to walk on its surface without introducing any deformation or damage to the surface or paint coatings.

**7.3.2.3 Floor****SRS** (PRTTDCIS-1391)

~~SRS-1144~~ The shelter interior floor panel shall be mechanically robust to support the weight of the internally installed equipment, ancillary items and the presence of military personnel.

**SRS** (PRTTDCIS-3128)

~~SRS-1145~~ The shelter floor panels shall be capable of supporting a uniform load of 320 kg/m<sup>2</sup> in accordance with ASTM E1925-18.

**SRS** (PRTTDCIS-3129)

~~SRS-1146~~ The shelter floor panels shall be capable of supporting a concentrated load of 900 kg over a 0.37m<sup>2</sup> area at the center of the floor.

**SRS** (PRTTDCIS-3130)

~~SRS-1147~~ The shelter floor panels shall be capable of supporting a point load of 57 kg over a 650mm<sup>2</sup> area.

**SRS** (PRTTDCIS-3131)

~~SRS-1148~~ The loads shall not cause any permanent deformation of the shelter floor panels or cause any deflections that interferes with proper shelter operation.

**SRS** (PRTTDCIS-3132)

~~SRS-1149~~ The shelter floors shall be horizontal and flat, with only a minimal sill at the doorframes.

**SRS** (PRTTDCIS-3133)

~~SRS-1150~~ The shelter floor panels shall have water drains that shall be closed by default, but capable of being opened without tools.

**SRS** (PRTTDCIS-3134)

~~SRS-1151~~ The shelter floor panel water drains shall be located at accessible points.

**SRS** (PRTTDCIS-3135)

~~SRS-1152~~ The shelter floor panel water drains shall have EMI shielded closing covers/lids, and ant-insect mesh.

**SRS** (PRTTDCIS-3136)

~~SRS-1153~~ The floors shall be of heavy-duty industrial type with surface finish.

**SRS** (PRTTDCIS-3137)

~~SRS-1154~~ The floor surfaces shall be non-reflecting.

**SRS** (PRTTDCIS-3138)

~~SRS-1155~~ The floor surfaces shall be fire-resistant to Fire class A1, according to EN 13501-1:2018.

**SRS** (PRTTDCIS-3139)

~~SRS-1156~~ The floor surfaces shall be non-toxic.

**SRS** (PRTTDCIS-3140)

~~SRS-1157~~ The floor shall neither attract nor harbour dust and be easy to clean. Therefore, no carpeting material shall be used.

**SRS** (PRTTDCIS-3141)

~~SRS-1158~~ The floor shall be anti-slip resistant to damp and commercial disinfectants and detergents.

**SRS** (PRTTDCIS-3142)

~~SRS-1159~~ The floors shall maintain electrostatic dissipative (ESD) and conductive coating performance without the need for special ESD waxes or polishes.

**SRS** (PRTTDCIS-3143)

~~SRS-1160~~ The floor shall meet requirements stipulated in:

- 1) EN 61340-5-1:2016 Electrostatics, Protection of electronic devices from electrostatic phenomena; and,
- 2) EN 61340-4-1:2004+A1:2015 Electrostatics, Standard test methods for specific applications and Electrical resistance of floor coverings and installed floors.

### 7.3.2.4 Cable trunking

**SRS** (PRTTDCIS-2117)

~~SRS-1161~~ The cable trunking shall provide, where necessary, for physical and/or electrical isolation/separation of the different internal cable harnesses.

**SRS** (PRTTDCIS-3145)

~~SRS-1162~~ Metallic information technology cabling and electrical power cabling shall be separated as specified in EN 50174-2:2018 - Information technology, Cabling installation, Installation planning and practices inside buildings.

**SRS** (PRTTDCIS-3146)

~~SRS-1163~~ The cable trunking shall be composed of a metallic reinforced frame for robustness.

**SRS** (PRTTDCIS-1394)

~~SRS-1164~~ The shelter internal wall structure shall support cable trunking mechanisms to support internal cable harnesses.

### 7.3.2.5 Cable aperture

#### SRS (PRTTDCIS-1396)

~~SRS-1165~~ The shelter back wall shall support a 100mm diameter aperture for the insertion of cabling between the inside/outside of the shelter.

#### SRS (PRTTDCIS-4520)

~~SRS-1166~~ When not in use, the 100mm cable aperture shall be sealed with a caps ensuring Shelter Environmental Endurance (e.g., water, dust, etc.), EMC and EMSEC specifications.

#### SRS (PRTTDCIS-4521)

~~SRS-1167~~ When in use, the 100mm cable aperture design shall prevent water (e.g. direct rain, cable following flow, etc.) to enter the shelter.

### 7.3.3 Racks

#### SRS (PRTTDCIS-2118)

~~SRS-1168~~ The shelter shall employ a 19in racking system for the installation of all the CIS equipment (e.g. power, radios, CIS, etc.) inside the shelter.

#### SRS (PRTTDCIS-2120)

~~SRS-1169~~ The racking system shall accommodate project deliverable components and integrate PFE elements.

#### SRS (PRTTDCIS-4584)

~~SRS-1170~~ Elements integration in racks shall be realized in such a way that:

- Elements can be removed without the need of removing other Elements; and,
- Elements can be pulled out of the rack while they are being operated (e.g. to control backside cables, LEDs, etc.).

#### SRS (PRTTDCIS-2121)

~~SRS-1171~~ Racks shall provide a minimum of additional room for future equipment per Security Domain as follow:

- BLK: FIVE (05) Rack Units (RU); and,
- xU: THREE (03) RU; and,
- xR: FIVE (05) RU; and,
- xS: THREE (03) RU.

**SRS** (PRTTDCIS-4583)

~~SRS-1172~~ Racks additional room for future equipment shall not be spread across racks but be grouped per Security Domain (i.e. One time five RU and not five times one RU spread across the rack)

**SRS** (PRTTDCIS-2122)

~~SRS-1173~~ The racking systems location in shelter shall be designed to minimize the shelter internal cable lengths.

**SRS** (PRTTDCIS-2123)

~~SRS-1174~~ The racking system shall support shock and damping systems to protect the mounted CIS equipment from the shock and vibration levels to which the shelter is exposed.

**SRS** (PRTTDCIS-2125)

~~SRS-1175~~ Racks shall be equipped with removable meshed panels covering rack fronts and all exposed rack backs and sides, without impacting air-flow and cooling performances of Elements mounted in the rack.

**SRS** (PRTTDCIS-4581)

~~SRS-1176~~ Racks removable meshed panels shall support the addition of padlocks.

**SRS** (PRTTDCIS-4582)

~~SRS-1177~~ Racks removable meshed panels shall be removable without the need of any key or tools.

**SRS** (PRTTDCIS-4533)

~~SRS-1178~~ Racks shall include patch panels to support, as a minimum, patching to Termination Panel, patching between racks and remote component ports which are not accessible when integrated in racks.



7.3.4 Electrical System

7.3.4.1 General

**NOTE** (PRTTDCIS-1406)

[206] The shelter electrical power concept is illustrated on the following picture:

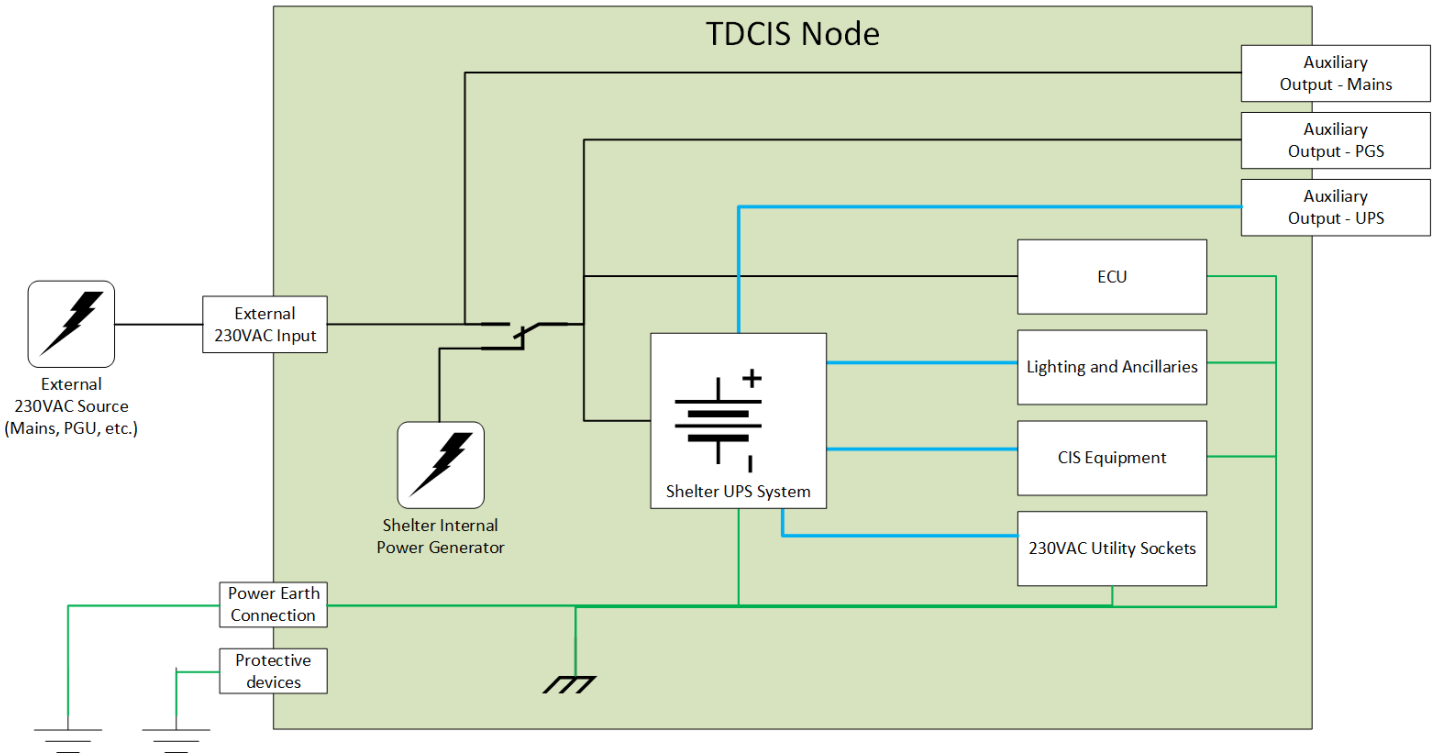

Figure 87 - Shelter Electrical Concept

**SRS** (PRTTDCIS-2144)

~~SRS-1179~~ It shall be possible to power the TDCIS Node electrical system by an external AC Power Source (Mains).

**SRS** (PRTTDCIS-3246)

~~SRS-1180~~ The Shelter main power input shall be of 230VAC single phase type.

**NOTE** (PRTTDCIS-4524)

[207] The Power distribution inside the shelter is design driven. i.e. it can be AC, DC or any combination of both.

**SRS** (PRTTDCIS-2145)

~~SRS-1181~~ It shall be possible to power the TDCIS Node electrical system from the shelter internal Power Generator Unit (PGU).

**SRS** (PRTTDCIS-4664)

~~SRS-1182~~ The Contractor shall implement security mechanisms preventing the System Administrator to power on the PGU from inside the shelter if necessary preliminary actions (e.g. door opening, flap opening, etc.) have not been executed.

**SRS** (PRTTDCIS-4665)

~~SRS-1183~~ The PGU starting preventing mechanisms will be feedback through LEDs visible inside the shelter.

**SRS** (PRTTDCIS-2154)

~~SRS-1184~~ Switching between mains and generator shall be performed manually.

**SRS** (PRTTDCIS-4522)

~~SRS-1185~~ Each Shelter shall include a minimum of FOUR (04) 230VAC Utility sockets, one per Security Domain (i.e. xU, xR, xS and BLK), inside the shelter.

**SRS** (PRTTDCIS-4539)

~~SRS-1186~~ Each Shelter shall include a minimum of Power External outputs as follow:

- Auxiliary Output - Mains used to daisy chain power supply from the Shelter Main Input to a second shelter or to a GAR-T trailer; and,
- Auxiliary Outputs - PGS used to provide power supply to the GAR-T HF Variant trailer for the RL Node Variant, to the NS Kit and to the Tent ECU; and,
- Auxiliary Outputs – UPS used to provide power supply to the Helpdesk tool kit of the Sys Admin Tent.

### 7.3.4.2 Electrical Distribution

**SRS** (PRTTDCIS-2146)

~~SRS-1187~~ The external 230VAC Input shall protect the shelter internal electrical system against surges and spikes as well as incorporate an isolation transformer to isolate the power earth references of the external power source from the Shelter Power Earth.

**SRS** (PRTTDCIS-2147)

~~SRS-1188~~ The 230VAC Input shall power:

- the ECU subsystem; and,
- the UPS subsystem; and,
- the Auxiliary Output - Mains.

**SRS** (PRTTDCIS-2148)

~~SRS-1189~~ The shelter UPS shall power with uninterrupted and filtered (clean) power following circuits:

- The lightning and ancillaries equipment; and,
- The CIS equipment; and,
- The 230VAC Utility Sockets.

**SRS** (PRTTDCIS-2150)

~~SRS-1190~~ The electrical distribution system shall segregate the power circuits by:

- Each Rack; and,
- Environmental Control Unit; and,
- Lighting; and,
- Utility sockets.

**SRS** (PRTTDCIS-2152)

~~SRS-1191~~ The Power distribution system shall power all Shelter housed elements, including PFE, and include provision for all Elements for which the Node variant has been marked as Enabled (e.g. Military SATCOM Terminal, CNR, etc.).

**SRS** (PRTTDCIS-2155)

~~SRS-1192~~ The shelter shall contain an electrical switchboard with the necessary circuit breakers and Residual Current Breakers (RCB) for AC and DC.

**SRS** (PRTTDCIS-4666)

~~SRS-1193~~ The Contractor shall implement separate Circuit Breakers for each Transmission System instance, each CNR instance and each Security Domain (including BLK).

**SRS** (PRTTDCIS-2156)

~~SRS-1194~~ The electrical switchboard shall contain the AC and the DC Distribution Panel.

**SRS** (PRTTDCIS-2157)

~~SRS-1195~~ The AC distribution panel shall display real time measurement of Voltage, Current and Frequency of the AC.

**SRS** (PRTTDCIS-1952)

~~SRS-1196~~ It shall be possible to daisy-chain up to TWO (02) shelters (i.e. the shelter itself plus one) on a single Main 230VAC input.

**SRS** (PRTTDCIS-2219)

~~SRS-1197~~ The Auxiliary 230VAC Output shall be protected with an isolator transformer and surge and spike arrestors.

### 7.3.4.3 Power Generation Unit

#### SRS (PRTTDCIS-2167)

~~SRS-1198~~ Each shelter shall be equipped with a Power Generator Unit (PGU).

#### SRS (PRTTDCIS-2169)

~~SRS-1199~~ The PGU will be the primary source of electrical power and shall be capable to provide continuous power to:

- All shelter internal CIS (i.e. communications equipment, servers, etc.); and,
- All shelter non-CIS systems (i.e. lighting, Environmental Control Unit (ECU), auxiliary equipment, etc.); and,
- Elements connected to the Auxiliary Output - PGS; and,
- Recharge simultaneously the UPS batteries in less than 3 hours.

#### SRS (PRTTDCIS-4534)

~~SRS-1200~~ The PGU in combination with the ECU shall be design in such a way that ECU startup current peak are accommodated and do not trigger circuit breakers.

#### NOTE (PRTTDCIS-4530)

~~[208]~~ The PGU will not provide power to the Auxiliary Output - Mains.

#### SRS (PRTTDCIS-2171)

~~SRS-1201~~ The refueling of the PGU shall be performed from the outside of the shelter.

#### SRS (PRTTDCIS-2173)

~~SRS-1202~~ The PGU enclosure shall be realized as a weatherproof cab tunnel or engineering cabinet of the shelter, providing sound isolation to the main working area of the shelter.

#### NOTE (PRTTDCIS-2448)

~~[209]~~ Fuel Jerry Cans to refill the Shelter PGU will be stored on the Vehicle transporting the Shelter. These are not to be considered as a Shelter payload. Shelter PGU Jerry Cans are PFE to this project.

#### SRS (PRTTDCIS-3487)

~~SRS-1203~~ The Shelter PGU shall be remotely monitored and controlled from inside the shelter.

#### SRS (PRTTDCIS-3350)

~~SRS-1204~~ It shall be possible to couple the PGU enclosure lighting to the mode selected for the Shelter.

**SRS** (PRTTDCIS-3351)

~~SRS-1205~~ It shall be possible to set the PGU enclosure lighting mode independently from the mode selected for the Shelter.

**SRS** (PRTTDCIS-3488)

~~SRS-1206~~ There shall be a PGU Control Panel inside the shelter which provides all functions and features of the Shelter PGU local Digital Diagnostic Control Panel.

**SRS** (PRTTDCIS-4523)

~~SRS-1207~~ The PGU shall be integrated with the LMM for monitoring and management.

#### 7.3.4.4 Uninterruptible Power Supply

**SRS** (PRTTDCIS-2177)

~~SRS-1208~~ All shelters shall contain an Uninterruptible Power Supply (UPS).

**SRS** (PRTTDCIS-2178)

~~SRS-1209~~ Output power levels of the UPS shall be in accordance to the power requirements of the installed CIS and non-CIS equipment.

**SRS** (PRTTDCIS-2179)

~~SRS-1210~~ The UPS battery system shall be capable of providing sufficient power to:

- Run the CIS equipment and the auxiliary equipment for a period of 30 minutes; and,
- Run the CNR for 12 hours; and,
- Run the lighting for 12 hours.

**NOTE** (PRTTDCIS-2180)

~~[210]~~ The UPS battery will not power the ECU.

**SRS** (PRTTDCIS-2181)

~~SRS-1211~~ After the specified UPS battery life period for the CIS equipment is over, enough battery power shall be available to perform a graceful shutdown of the CIS systems.

**SRS** (PRTTDCIS-2182)

~~SRS-1212~~ The UPS shall be integrated with the LMM for monitoring, management and to trigger the graceful shutdown.

**SRS** (PRTTDCIS-2183)

~~SRS-1213~~ The UPS and its battery system shall be designed to meet the power demand of the most power consuming Node variant shelter version.

**SRS** (PRTTDCIS-2184)

~~SRS-1214~~ The UPS and its battery system shall be fitted identically to all shelter types without resizing.

**SRS** (PRTTDCIS-2185)

~~SRS-1215~~ The UPS battery system shall be capable of operating in a low ventilation environment (i.e. without air conditioning).

**7.3.4.5 Lighting****SRS** (PRTTDCIS-2194)

~~SRS-1216~~ The Shelter LED-based lighting system shall be ceiling mounted

**SRS** (PRTTDCIS-2193)

~~SRS-1217~~ When the lighting system is in Normal Mode it shall support automatically switch to Combat Mode when the shelter door is opened.

**SRS** (PRTTDCIS-2188)

~~SRS-1218~~ The shelter internal lighting system shall be controlled through a "Lighting Control Panel".

**SRS** (PRTTDCIS-2189)

~~SRS-1219~~ The Lighting Control Panel shall support the following switch modes:

- OFF; and,
- Garrison Operation Mode (in which the lights are always white); and,
- Normal Operation Mode (in which the lights are normally white and change to red when the door opens); and,
- Combat Mode (in which the lights are always red).

**SRS** (PRTTDCIS-2190)

~~SRS-1220~~ The Normal Mode lighting system shall be measured in Kelvin and have a colour temperature between 2,800K and 3,000K.

**SRS** (PRTTDCIS-2191)

~~SRS-1221~~ The Combat Mode lighting system shall have wavelength between 625nm and 650nm.

**SRS** (PRTTDCIS-2192)

~~SRS-1222~~ The shelter internal lighting system shall provide a minimum illumination at the floor level of 300 lux/m<sup>2</sup>.

**SRS** (PRTTDCIS-2187)

~~SRS-1223~~ The shelter internal lighting system shall have a life cycle duration of 20,000 hours.

### 7.3.4.6 Power Earth and Grounding

#### SRS (PRTTDCIS-2195)

~~SRS-1224~~ All shelters shall include a set of four grounding stakes with 3m long connecting meshes to establish a low impedance physical contact between the shelter and the ground.

#### SRS (PRTTDCIS-2196)

~~SRS-1225~~ The grounding stakes and meshes shall be transported and stored inside the shelter.

#### SRS (PRTTDCIS-2197)

~~SRS-1226~~ The shelter ground resistance from any point to earth shall be in accordance with the PRT regulations and where possible, be 5 ohms or less.

### 7.3.5 Environmental Control Unit

#### SRS (PRTTDCIS-2205)

~~SRS-1227~~ The Environmental Control Unit (ECU) shall ensure that the cooled airflow will efficiently be directed to the racks and equipment.

#### SRS (PRTTDCIS-2206)

~~SRS-1228~~ Under the specified most extreme operation conditions, the ECU shall be capable of;

- Maintaining an air temperature of +18 degrees Celsius, +/- 2 degrees Celsius inside the shelter, at minimum outside temperature exposure; and
- Maintain an air temperature of +20 degrees Celsius, +/- 2 degrees Celsius inside the shelter, at maximum outside temperature and solar radiation exposure.

#### SRS (PRTTDCIS-2207)

~~SRS-1229~~ The ECU shall be capable of being controlled and monitored via an "ECU Remote Control Unit" located inside the shelter and reachable by a System Administrator.

#### SRS (PRTTDCIS-2208)

~~SRS-1230~~ The ECU Remote Control Unit shall support the selection of the following modes:

- Refrigeration; and,
- Heating; and,
- Ventilation (i.e. using air from outside); and,
- Recirculation (i.e. blocking air from outside).

#### SRS (PRTTDCIS-2209)

~~SRS-1231~~ The ECU Remote Control Unit shall be integrated with the LMM for monitoring and management.

**SRS** (PRTTDCIS-2395)

~~SRS-1232~~ The shelter shall be designed in overpressure meaning that during operation, the overall internal pressure of the shelter will always be higher than the external pressure in all operating conditions.

**SRS** (PRTTDCIS-3107)

~~SRS-1233~~ The shelter shall be designed to provide fresh-air ventilation.

**SRS** (PRTTDCIS-3026)

~~SRS-1234~~ ECU components requiring regular maintenance (e.g. filters) shall be easily accessible for a technician without having to remove TDCIS node components (other than opening a hatch or a vent) or interrupt any services.

**SRS** (PRTTDCIS-4531)

~~SRS-1235~~ ECU shall be design in such a way that it does not blow air in a direct way to the System Administrator sitting at the temporary working position.

## 7.3.6 Termination Panels

### 7.3.6.1 General

**SRS** (PRTTDCIS-2210)

~~SRS-1236~~ All shelters shall support the following External and Internal Termination Panels.

- External Power Panel (EPP); and,
- External Communications Panel (ECP); and,
- External Line of Sight Roof Panel (ELOS RP); and,
- External SATCOM Roof Panel (ESATRP); and,
- External RF Panels (ERFP); and,
- External Commercial Communication Roof Panel (ECCRP); and,
- Internal RF Panels (IRFP).

**NOTE** (PRTTDCIS-2211)

~~[211]~~ The external panels can be located on any of the shelter's walls or roof, as long as these do not protrude outside of the shelter "free area" envelope.

**NOTE** (PRTTDCIS-4667)

~~[212]~~ Should roof panels be used, those shall prevent accumulation of Water, Snow, Dust, Sand, Ice, etc., in line with Environmental performance targets, even when cables are connected.



**SRS** (PRTTDCIS-2212)

~~SRS-1237~~ All Communications shelter external panels shall be protected by a hinged flap door with rubber side protections unfolding when opened.

**SRS** (PRTTDCIS-2213)

~~SRS-1238~~ The hinged flap door shall open along the horizontal top axis of the door.

**SRS** (PRTTDCIS-2214)

~~SRS-1239~~ The hinged flap door shall have a locking mechanism when closed and a support mechanism when opened to prevent cable damage.

**SRS** (PRTTDCIS-2215)

~~SRS-1240~~ All panels shall be labelled beneath the protective flap door.

**SRS** (PRTTDCIS-2216)

~~SRS-1241~~ All connectors shall be labelled with a reference and keyword as to its functionality (e.g. AC INPUT, Protective Power Earth, Ethernet, etc.).

**SRS** (PRTTDCIS-2217)

~~SRS-1242~~ All external connectors shall be easy to access from the outside of the shelter. No outer parts or structures shall interfere with the ease of connection and fixation of the connector.

**SRS** (PRTTDCIS-3231)

~~SRS-1243~~ All External Termination Panels shall include lightning and surge protection components for all connectors where applicable (Power, RF, Copper base network ports...).

**SRS** (PRTTDCIS-4668)

~~SRS-1244~~ All External Termination Panels shall contain an anti-traction protection mechanism, matching anti-traction solution for cables.

### 7.3.6.2 External Power Panel

#### SRS (PRTTDCIS-2218)

~~SRS-1245~~ The External Power Panel (EPP) connector quantities are design driven. EPP shall implement, as a minimum:

- ONE (01) panel mounted IEC 60309, 230VAC, 32A, 50/60 Hz, 2 pole connector (single phase) and Power Earth with protective cap and ingress protection to IP67 or better, labelled as INPUT; and,
- ONE (01) panel mounted IEC 60309, 230VAC, 32A, 50/60 Hz, 2 pole connector (single phase) and Power Earth with protective cap and ingress protection to IP67 or better, labelled as AUXILIARY OUTPUT - MAINS; and,
- THREE (03) panel mounted IEC 60309, 230VAC, 32A, 50/60 Hz, 2 pole connector (single phase) and Power Earth with protective cap and ingress protection to IP67 or better, labelled as :
  - AUXILIARY OUTPUT – PGS - 01; and,
  - AUXILIARY OUTPUT – PGS - 02; and,
  - AUXILIARY OUTPUT – PGS - 03; and,
- TWO (02) panel mounted CEE 7/3 type, 230VAC, 50/60 Hz, 16 A, 2 poles with Power Earth, socket with protective cap and ingress protection to IP67 or better, labelled as :
  - AUXILIARY OUTPUT – UPS - 01; and,
  - AUXILIARY OUTPUT – UPS - 02; and,
- TWO (02) Power Earth Stub Connectors.

### 7.3.6.3 External Communication Panel

#### SRS (PRTTDCIS-2221)

~~SRS-1246~~ The External Communication Panel (ECP) shall support:

- MIL-DTL-38999 standard RJFTV (square flange receptacle) Class D / Cat. 6 or better Ethernet sockets supporting female RJ45 back termination; and,
- Two Channel Single Mode (SM) HxMA flange mount bulkhead optical connectors; and,
- Pairs of press (binding posts) for Single Pair, High Speed Digital Subscriber Line (SHDSL) and Connection of Analog Phones.

**SRS** (PRTTDCIS-2222)

~~SRS-1247~~ The minimum quantity of connectors required on the ECP is design driven. The ECP shall support additional connectors quantities as per following table:

	RJ45	HxMA	Binding Post (Pairs)
<b>BLK</b>	4	4	4
<b>xU</b>	4	4	4
<b>xR</b>	4	4	-
<b>xS</b>	4	4	-

Table 41 - ECP additional connectors quantities

**SRS** (PRTTDCIS-2223)

~~SRS-1248~~ The different security domain connectors shall be grouped together and colour labelled on the ECP.

**7.3.6.4 External Line of Sight Roof Panel**

**SRS** (PRTTDCIS-2224)

~~SRS-1249~~ The shelter shall support TWO (02) External Line of Sight Roof Panels (ELOS RP) to pass communication, power and control signals to the HCLOS and Mini LOS radios systems.

**SRS** (PRTTDCIS-2225)

~~SRS-1250~~ Each ELOS RP panel shall be located adjacent to the electrically motorised telescopic mast mounting point.

**SRS** (PRTTDCIS-2226)

~~SRS-1251~~ The ELOS RP shall support a set of panel connectors to pass communication signals to the HCLOS and Mini LOS radios systems and a set of panel connectors to pass power and control signals to the HCLOS and Mini LOS radios systems.

**SRS** (PRTTDCIS-2227)

~~SRS-1252~~ The ELOS RPs shall include surge arrester filters

**7.3.6.5 External SATCOM Roof Panel**

**SRS** (PRTTDCIS-2228)

~~SRS-1253~~ The shelter shall support ONE (01) External SATCOM Roof Panel (ESATRP) to pass communication signals, power and control to the Outdoor Units (ODU) of the Military SATCOM Terminal antenna subsystem (e.g. dish and other ancillary equipment).

**SRS** (PRTTDCIS-2229)

~~SRS-1254~~ The ESATRP shall support a set of panel connectors to pass communication signals to the Military SATCOM Terminal antenna subsystem and a set of panel connectors to pass power and control signals to the Military SATCOM Terminal antenna subsystem.

**SRS** (PRTTDCIS-2230)

~~SRS-1255~~ The ESATRP shall include surge arrester filters.

**7.3.6.6 External RF Panel****SRS** (PRTTDCIS-2231)

~~SRS-1256~~ The communications shelter shall support SIX (06) External RF Panels (ERFP) to pass communication signals to the whip antennas.

**SRS** (PRTTDCIS-2232)

~~SRS-1257~~ Each ERFP panel shall be located adjacent to the whip antenna mounting point.

**SRS** (PRTTDCIS-2233)

~~SRS-1258~~ Each ERFPs shall include, as a minimum, TWO (02) type N female coaxial connectors and TWO (02) type TNC female coaxial connectors.

**SRS** (PRTTDCIS-2234)

~~SRS-1259~~ All ERFPs shall include surge arrester filters.

**SRS** (PRTTDCIS-2235)

~~SRS-1260~~ The shelter shall provide a structure within the shelter "allocable area" for the installation of the CNR 150W HF Antenna Tuning Unit (ATU) having the approximate following dimensions and weight:

- Dimension 147 x 72 x 225 mm (W x D x H); and,
- Weight 2Kg

**SRS** (PRTTDCIS-2236)

~~SRS-1261~~ The shelter shall support an additional ERFP located on the lateral side of the shelter in support of the RL Node HF antenna mounted on the GAR-T Rear link version, with a high power capable (1kW CW) RF interface.

**7.3.6.7 External Commercial Communication Roof Panel****SRS** (PRTTDCIS-2237)

~~SRS-1262~~ The communications shelter shall support an External Commercial Communication Roof Panel (ECCRP) to pass BGAN, Iridium and IMT Network communication signals to the BGAN, Iridium and IMT Network antennas.

**SRS** (PRTTDCIS-2238)

~~SRS-1263~~ The ECCRP shall support both type N female coaxial connectors and type TNC female coaxial connectors.

**NOTE** (PRTTDCIS-2239)

[243] The exact type and number of ECCRP connectors will be design-driven from the type of antenna system selected by the contractor.

**SRS** (PRTTDCIS-2240)

~~SRS-1264~~ The ECSRP shall include surge arrester filters.

### 7.3.6.8 Internal RF Panels

**SRS** (PRTTDCIS-2241)

~~SRS-1265~~ The shelter shall support an internal RF Panel (IRFP) to patch and route RF signals between the Indoor Communication Units and all the ERFPs.

**SRS** (PRTTDCIS-2242)

~~SRS-1266~~ The IRFP shall be located adjacent to the rack hosting radio Indoor Units (IDU).

**SRS** (PRTTDCIS-2243)

~~SRS-1267~~ The quantities and types of IRFP connectors shall be equivalent to the matching ERFp connectors.

### 7.3.7 Antennas and masts

**SRS** (PRTTDCIS-2245)

~~SRS-1268~~ The shelter shall support, on the shelter roof, the specified terminal and antennas in size and quantities, e.g.

- The Military SATCOM terminal; and,
- The Commercial SATCOM terminal; and,
- The Iridium terminal outdoor unit; and,
- Two vehicle mounted (voice/data) IMT Network antennas.

**SRS** (PRTTDCIS-2246)

~~SRS-1269~~ The Military SATCOM terminal shall remain mounted on the roof of the shelter, when in transport (i.e. folded) and when in operation (i.e. deployed).

**SRS** (PRTTDCIS-2247)

**SRS-1270** All shelters shall support, on the roof or on the sides, the following:

- SIX (06) mobile vehicle mounted “whip” antennas; and,
- TWO (02) electrically motorized telescopic masts in support of the HCLOS and MiniLOS ODUs.

**NOTE** (PRTTDCIS-2248)

**[214]** The mobile vehicle mounted “whip” antennas supporting the CNR and the IP HF Radio are PFE.

**SRS** (PRTTDCIS-2249)

**SRS-1271** Each mobile vehicle mounted “whip” antenna (CNR, IP HF Radio, or Broadband Radio) shall be mounted on a “mounting point” located within the shelter “allocable area” or on the shelter roof.

**SRS** (PRTTDCIS-2250)

**SRS-1272** Mobile vehicle mounted “whip” antennas mounting points shall be in accordance with the NATO 4-hole mounting base specification, as shown in following figure:

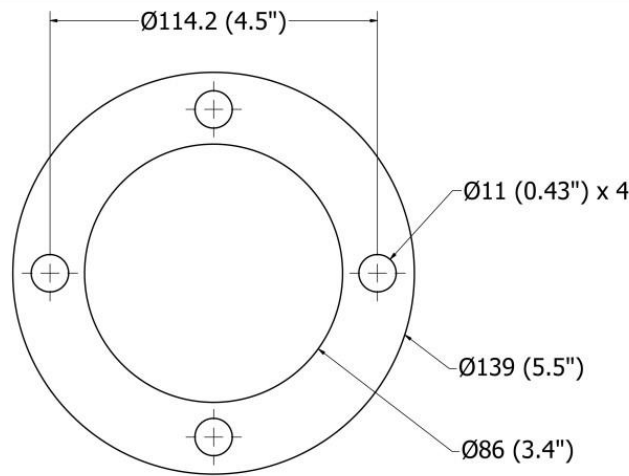

Figure 88 - TO 4-hole base pattern

**SRS** (PRTTDCIS-2251)

**SRS-1273** The two electrically motorised telescopic masts shall be fixed to the communications shelter external side panels.

**SRS** (PRTTDCIS-2252)

**SRS-1274** When these masts are retracted (during transport), the full body shall fall within the “allocable area” of the shelter envelope.

**SRS** (PRTTDCIS-2253)

~~SRS-1275~~ The two electrically motorised telescopic masts shall when fully extended; have a height of at least 10.5m measured from the shelter “zero height reference”.

**SRS** (PRTTDCIS-2254)

~~SRS-1276~~ The two electrically motorised telescopic masts shall (together) support up to a maximum of FOUR (04) radio systems (e.g. 4 HCLOS, 3 Mini-LOS plus 1 HCLOS, etc.).

**SRS** (PRTTDCIS-2255)

~~SRS-1277~~ It shall be possible to raise and lower the two motorised telescopic masts with all equipment mounted (i.e. antennas, rotors, radios adapters, cables, etc.).

**SRS** (PRTTDCIS-2256)

~~SRS-1278~~ The motorised telescopic masts shall be powered by the shelter power system.

**SRS** (PRTTDCIS-2257)

~~SRS-1279~~ Operation of the two motorised telescopic masts shall be possible through the use of a remote control system.

**SRS** (PRTTDCIS-2258)

~~SRS-1280~~ It shall be possible to raise and lower the motorised telescopic masts manually (i.e. in case of total power failure) by a single System Administrator within 600 seconds.

**SRS** (PRTTDCIS-4545)

~~SRS-1281~~ Only Nodes delivered with HCLOS or Mini-LOS shall be delivered with Electrically Motorized Masts.

**SRS** (PRTTDCIS-4546)

~~SRS-1282~~ In the case of a Node with double shelter, only the Communication Shelter shall be delivered with Electrically Motorized Masts.

**SRS** (PRTTDCIS-4669)

~~SRS-1283~~ It shall be possible to transfer ONE (01) Electrically Motorized Masts from one shelter to another with TWO (02) trained operators in no more than TWO (04) hours without the need of lifting equipment.

## 7.3.8 Ancillary Equipment

### 7.3.8.1 General

#### SRS (PRTTDCIS-2165)

~~SRS-1284~~ All shelters shall include the following internal ancillary equipment to be stowed inside the shelter;

- Storage compartment(s) for the transportation and accommodation of general purpose equipment and accessories; and,
- ONE (01) Magnetic “white” marker board” having approximate dimensions of 430 x 840 mm; and,
- ONE (01) wall mounted folding steel table painted in RAL 840R 6014, non-gloss or equivalent; and,
- TWO (02) folding steel table painted in RAL 840R 6014, non-gloss or equivalent; and,
- TWO (02) folding steel chairs for use with the folding table, painted in RAL 840R 6014, non-gloss or equivalent; and,
- ONE (01) pickaxe, with a handle shaft approx. 46cm long and drop forged carbon steel head, hardened and tempered for durability, painted in RAL 840R 6014, non-gloss or equivalent; and,
- ONE (01) sledge hammer, with handle shaft approx. 70cm long, 40mm in diameter, painted in RAL 840R 6014, non-gloss or equivalent; and,
- ONE (01) shovel, with a handle shaft approx. 70cm long, approx. 17cm wide carbon steel blade with collar at the handle/socket connection for added strength, forward turned step for secure foot placement, painted in RAL 840R 6014, non-gloss or equivalent; and,
- ONE (01) 6 kg portal ABC dry powder fire extinguishers Class ABC and suitable for fires involving electronic equipment up to 1000 V, mounted in such a manner that it is located in highly visible and easily accessible place; and,
- ONE (01) First Aid kit located in a highly visible location with provision adequate for TWO (02) staff.

#### SRS (PRTTDCIS-3148)

~~SRS-1285~~ The fire extinguisher shall meet requirements as stipulated in following standards:

- EN 3-7:2004+A1:2007 Portable fire extinguishers. Characteristics, performance requirements and test methods; and,
- EN 3-8:2006 Portable fire extinguishers. Additional requirements to EN 3-7 for the construction, resistance to pressure and mechanical tests for extinguishers with a maximum allowable pressure equal to or lower than 30 bar; and,
- EN 3-10:2009 Portable fire extinguishers. Provisions for evaluating the conformity of a portable fire extinguisher to EN 3-7.



**SRS** (PRTTDCIS-2166)

**SRS-1286** All shelters shall include the following external ancillary equipment;

- ONE (01) anodised aluminium plate providing information pertaining to air (as internal cargo load and as helicopter external load), land, maritime and railways transportation.
- Retractable supports to access the shelter roof. The supports shall be placed on the outside of the communications shelter.
- ONE (01) adjustable folding ladder, painted in RAL 840R 6014, non-gloss or equivalent, providing access to all areas of the communications shelter structure. The ladder shall be stowed on the outside of the communications shelter.

**SRS** (PRTTDCIS-3215)

**SRS-1287** Shelter shall be equipped with wind tie-downs to cater for the environmental conditions it has to comply with.

**SRS** (PRTTDCIS-3216)

**SRS-1288** When designing the wind tie-downs the Contractor shall consider the shelter sitting on the Vehicle with Vehicle stabilization legs deployed as the worst case scenario.

**SRS** (PRTTDCIS-4535)

**SRS-1289** Every Shelter shall be equipped with a fire prevention system compliant with PRT National Fire prevention regulation and including, as a minimum, smoke detectors inside the shelter and in the PGU compartment.

**SRS** (PRTTDCIS-4536)

**SRS-1290** Shelter prevention system shall be integrated in the LMM to, as a minimum, relay smoke detector alarms and identify the compartment.

**7.3.8.2 Sys Admin Tent****7.3.8.2.1 General****SRS** (PRTTDCIS-3010)

**SRS-1291** ONE (01) Tent shall be delivered per Node for the System Administrators helpdesk.

**SRS** (PRTTDCIS-2750)

**SRS-1292** Tents shall be stored ~~inside~~ the shelter or in any of its allocable areas.

**SRS** (PRTTDCIS-4735)

Tent shall not always be deployed. Therefore, keeping the tent in its storage emplacement shall not prevent the operation of the Shelter nor any of its housed elements in any Node variant configuration.

**SRS** (PRTTDCIS-2751)

~~SRS-1293~~ Each tent shall be provided with a set of installation tools.

**SRS** (PRTTDCIS-2752)

~~SRS-1294~~ Each tent shall be delivered with three repair and maintenance kits, one for echelon/level 1 repairs, one for echelon/level 2 repairs and one for echelon/level 3 repairs.

**SRS** (PRTTDCIS-2754)

~~SRS-1295~~ Tents shall be of inflatable type and allow operation under heavy snow without collapsing inward.

**SRS** (PRTTDCIS-3013)

~~SRS-1296~~ The Tent shall include floor and table power distribution for the System Administrators equipment and lighting consisting of fluorescent light Units (or LED) similar to those used in the shelter.

**SRS** (PRTTDCIS-2755)

~~SRS-1297~~ It shall be possible to switch lights inside the tents from white to red (combat mode).

**SRS** (PRTTDCIS-2756)

~~SRS-1298~~ Tents shall implement sufficient air flow to avoid the accumulation of heat in any space.

**SRS** (PRTTDCIS-2758)

~~SRS-1299~~ All visible tent surfaces shall be the same color as for the Shelters external surfaces.

**SRS** (PRTTDCIS-2763)

~~SRS-1300~~ The Tent shall be suitable to host TWO (02) staff members with their working position and the furniture stored in the shelter while taking into consideration the separation distance required between elements of belonging to different security domains.

**SRS** (PRTTDCIS-3011)

~~SRS-1301~~ It shall be possible to create bigger tent by attaching multiple tents together.

**SRS** (PRTTDCIS-2753)

~~SRS-1302~~ Tents shall be deployable in all climatic areas and on soft or hard surfaces (i.e. concrete surface), therefore adequate sunshields and weights (i.e. water ballast) shall be delivered with the tents.

**SRS** (PRTTDCIS-3166)

~~SRS-1303~~ The tent configuration shall assure rapid deployment without aid of ancillary equipment.

**SRS** (PRTTDCIS-3167)

~~SRS-1304~~ The tent configuration shall assure that packaging allows the tent to be moved / stowed by TWO (02) people.

**SRS** (PRTTDCIS-3168)

~~SRS-1305~~ The tent shall have vertical sidewalls of minimum 150 cm height to maximize usable space on its floor.

**SRS** (PRTTDCIS-3169)

~~SRS-1306~~ The tent height at the apex shall be minimum 210 cm.

**SRS** (PRTTDCIS-3170)

~~SRS-1307~~ The tent doors shall be at both ends with double ties and overlap.

**SRS** (PRTTDCIS-3171)

~~SRS-1308~~ The tent fabric shall be UV resistant.

**SRS** (PRTTDCIS-3172)

~~SRS-1309~~ The tent shall be equipped with at least one roof vent cap.

**SRS** (PRTTDCIS-3173)

~~SRS-1310~~ The tent shall be equipped with at least one sealable (for example with a cover with Velcro fasteners) opening in the sidewalls to allow installation of flexible ducting from the Sys Admin Tent ECU.

**SRS** (PRTTDCIS-3175)

~~SRS-1311~~ The tent floor shall be vinyl and flame retardant.

**SRS** (PRTTDCIS-3176)

~~SRS-1312~~ The tent shall withstand wind load of 89 km/h with gusts up to 105 km/h.

**SRS** (PRTTDCIS-3177)

~~SRS-1313~~ The tent shall withstand snow load of 50 kg/m<sup>2</sup> for minimum 12 hours.

**SRS** (PRTTDCIS-4537)

~~SRS-1314~~ The tent shall include a detachable extension tunnel to allow connection between the tent and the shelter, on the shelter door side.

**SRS** (PRTTDCIS-4538)

~~SRS-1315~~ The tent detachable extension tunnel shall support both shelter on the ground and shelter on vehicle positions.

**SRS** (PRTTDCIS-3012)

~~SRS-1316~~ Tent shall include a Helpdesk tool kit to the benefit of the System Administrators while working in the Tent, consisting of:

- ONE (01) semi-rugged network switch for each security domain (including BLK), each including a minimum of 2 PoE ports ;and,
- Sufficient table-top fixable heavy duty power strips; and
- Sufficient patch and power cables to connect from the shelter Termination Panel to the Tent and inside the Tent.

**SRS** (PRTTDCIS-4670)

~~SRS-1317~~ All Helpdesk tool kit semi-rugged switches shall be of identical model in all security domains.

**SRS** (PRTTDCIS-4671)

~~SRS-1318~~ The Contractor shall ensure that Helpdesk tool kit semi-rugged switches, while being operated, shall meet all Security performance targets (e.g. power line filtering, emission limits, etc.) specific to the security Domain it is connected to.

**SRS** (PRTTDCIS-3014)

~~SRS-1319~~ The Shelter UPS endurance shall include all helpdesk elements (network components, Tent lighting, etc.), with the exception of System Administrator workstations, in its computation.

**7.3.8.2.2 Sys Admin Tent ECU****SRS** (PRTTDCIS-4672)

~~SRS-1320~~ The Sys Admin Tent ECU shall meet or exceed following performances:

- Cooling capacity between 5000 BTU and 7000 BTU; and,
- Heating Capacity between 900 kW and 1100 kW.

**SRS** (PRTTDCIS-4673)

~~SRS-1321~~ The Sys Admin Tent ECU total Weight shall not exceed 55 kg.

**SRS** (PRTTDCIS-4674)

~~SRS-1322~~ The Sys Admin Tent ECU shall be integrated in a Case.

**SRS** (PRTTDCIS-4675)

~~SRS-1323~~ The Sys Admin Tent ECU shall meet:

- OPE-1a if operated from outside of the Sys Admin Tent; or,
- OPE-1c if operated from inside the Sys Admin Tent.

**SRS** (PRTTDCIS-4676)

~~SRS-1324~~ The Sys Admin Tent ECU shall be powered from the Shelter.

**NOTE** (PRTTDCIS-4677)

~~[245]~~ The Sys Admin Tent ECU will not be considered as a payload for the dimensioning of the Shelter PGU and the Shelter UPS.

**NOTE** (PRTTDCIS-4678)

~~[246]~~ The Sys Admin Tent ECU will be transported in a separate Vehicle. Therefore the Sys Admin Tent ECU is not to be considered as a Shelter Payload.

### 7.3.9 Lifting Jacks Kit

**NOTE** (PRTTDCIS-3542)

~~[247]~~ The Lifting Jacks Kit will be used to load and unload a shelter from a Vehicle. It is to be considered as a Material Handling Equipment (MHE) which will be transported in separate Vehicle than the Shelter carrier. Therefore it is not to be considered as part of the Shelter payload.

**SRS** (PRTTDCIS-3516)

~~SRS-1325~~ Each Lifting Jacks Kit shall be composed by FOUR (04) electrically operated jacks.

**SRS** (PRTTDCIS-3517)

~~SRS-1326~~ The Lifting Jacks Kit shall include all necessary components to be powered by a 24VDC power source.

**SRS** (PRTTDCIS-3518)

~~SRS-1327~~ The Lifting Jacks Kit shall include all necessary components to be powered by a 230VAC - single phase power source.

**SRS** (PRTTDCIS-3521)

~~SRS-1328~~ Each Lifting Jacks Kit shall be controlled via a cabled or wireless remote control console, capable of operating over a distance of not less than 15 meters.

**SRS** (PRTTDCIS-3524)

~~SRS-1329~~ The Lifting Jacks Kit shall allow a maximum Shelter-Ground clearance of 1650 mm.

**SRS** (PRTTDCIS-3526)

~~SRS-1330~~ The Lifting Jacks Kit shall be capable of raising and lowering the shelter when fully loaded with all components, equipment and accessories.

**SRS** (PRTTDCIS-3537)

~~SRS-1334~~ The Lifting Jacks Kit shall be capable of raising and lowering ISO certified containers of any dimension.

**SRS** (PRTTDCIS-3538)

~~SRS-1332~~ The Lifting Jacks Kit minimum lift capacity shall be 5000kg.

**NOTE** (PRTTDCIS-3529)

[248] The Lifting Jacks Kit will be operated on solid ground (e.g. concrete or tarmac) with a maximum ground slope not exceeding 5 degrees across the area of the container being lifted.

**SRS** (PRTTDCIS-3532)

~~SRS-1333~~ The Lifting Jacks Kit shall be CE certified and designed according to EN 1494:2000+A1:2008 Mobile or movable jacks and associated lifting equipment.

**SRS** (PRTTDCIS-3533)

~~SRS-1334~~ The Lifting Jacks Kit shall be equipped with a tilt sensor.

**SRS** (PRTTDCIS-3534)

~~SRS-1335~~ The Lifting Jacks Kit shall be equipped with a control system synchronising the action of all the kit's lifting jacks, when raising a single container.

**SRS** (PRTTDCIS-3535)

~~SRS-1336~~ The Lifting Jacks Kit shall embed safety mechanisms preventing its operation, in the event it has not been fitted to a container and prepared for operation in the correct manner.

**SRS** (PRTTDCIS-3536)

~~SRS-1337~~ Each Lifting Jacks Kit shall control the automatic leveling of the shelter while it is loaded on and unloaded from a Vehicle.

**SRS** (PRTTDCIS-3539)

~~SRS-1338~~ The Lifting Jacks Kit shall require a maximum of TWO (02) trained System Administrators for its installation and operation.

**SRS** (PRTTDCIS-3540)

~~SRS-1339~~ The Lifting Jacks Kit operating temperature range shall be from -10 degrees Celsius to +49 degrees Celsius.

**SRS** (PRTTDCIS-3541)

~~SRS-1340~~ Installation of the Lifting Jacks Kit shall only rely on the standard locking mechanism of ISO corners.

**SRS** (PRTTDCIS-3543)

~~SRS-1341~~ The Lifting Jacks Kit shall be delivered in transport cases containing all its elements and meeting all transportation constraints.

### 7.3.10 Maintenance Platform

**NOTE** (PRTTDCIS-3150)

~~[219]~~ Shelter maintenance platform is not to be stored in any container or vehicle. It will be used at PRT Peacetime Location maintenance facility or deployed to a forward logistic support unit.

**SRS** (PRTTDCIS-3151)

~~SRS-1342~~ The Shelter Maintenance Platform shall be foldable, aluminium, waterproofed, light but sturdy structure, easily installed and detachable from the shelter.

**SRS** (PRTTDCIS-3152)

~~SRS-1343~~ The Shelter Maintenance Platform shall be equipped with wheels that support easy movement over hard surfaces with wheel breaking mechanism.

**SRS** (PRTTDCIS-3153)

~~SRS-1344~~ The Shelter Maintenance Platform shall be manually adjustable in height enabling elevation of the platform deck to the same level as the shelter roof when the shelter is resting on fully extended lifting legs and on the vehicle.

**SRS** (PRTTDCIS-3154)

~~SRS-1345~~ The Shelter Maintenance Platform shall be equipped with stairs (manually adjustable height), with railing on at least one side, that provides access to the platform deck when the platform is extended at full height.

**SRS** (PRTTDCIS-3155)

~~SRS-1346~~ The Shelter Maintenance Platform stairs at their upper/top end shall be equipped with self-closing and latching inward opening.

**SRS** (PRTTDCIS-3156)

~~SRS-1347~~ The Shelter Maintenance Platform deck shall be equipped with railing mounted along the deck edge facing outwards the platform.

**SRS** (PRTTDCIS-3157)

~~SRS-1348~~ The Shelter Maintenance Platform deck as well as the stairs shall form non-slip, self-draining surface.

**SRS** (PRTTDCIS-3158)

~~SRS-1349~~ The Shelter Maintenance Platform shall have a load bearing capacity minimum 200 kg/m<sup>2</sup>.

**SRS** (PRTTDCIS-3159)

~~SRS-1350~~ The Shelter Maintenance Platform deck width shall be minimum 80 cm.

**SRS** (PRTTDCIS-3160)

~~SRS-1351~~ The Shelter Maintenance Platform stairs width shall be minimum 60 cm.

**SRS** (PRTTDCIS-3161)

~~SRS-1352~~ The Shelter Maintenance Platform deck railing height shall be minimum 110 cm.

**SRS** (PRTTDCIS-3162)

~~SRS-1353~~ The Shelter Maintenance Platform stairs railing height shall be minimum 90 cm.

**SRS** (PRTTDCIS-3163)

~~SRS-1354~~ The Shelter Maintenance Platform deck shall form a "U" shape in order to enable access to shelter roof from three (3) sides at the same time.

**SRS** (PRTTDCIS-3164)

~~SRS-1355~~ The Shelter Maintenance Platform including stairs, railing and its other components shall be compliant with ISO 14122 series.

**SRS** (PRTTDCIS-3165)

~~SRS-1356~~ The Shelter Maintenance Platform shall be able to withstand the same climatic and environmental conditions as the DPOP.



## 7.4 Trailer

### 7.4.1 Common Base

#### 7.4.1.1 General

##### NOTE (PRTTDCIS-2263)

~~[220]~~ The GAR-T has a common base structure, consisting of;

- Mechanical; (i.e. trailer, etc.); and,
- Electrical Power; and,
- Telescopic Antenna Mast; and,
- Ancillary Equipment.

##### SRS (PRTTDCIS-1504)

~~SRS-1357~~ The GAR-T Trailer is the housing element for CIS and non-CIS assets for the Rear Link HF trailer and for the HCLOS Relay trailer. Following figure illustrates the GAR-T Trailer breakdown structure. It identifies the elements it is composed of. Each GAR-T Trailer shall be built upon the building blocks as identified in this reference.

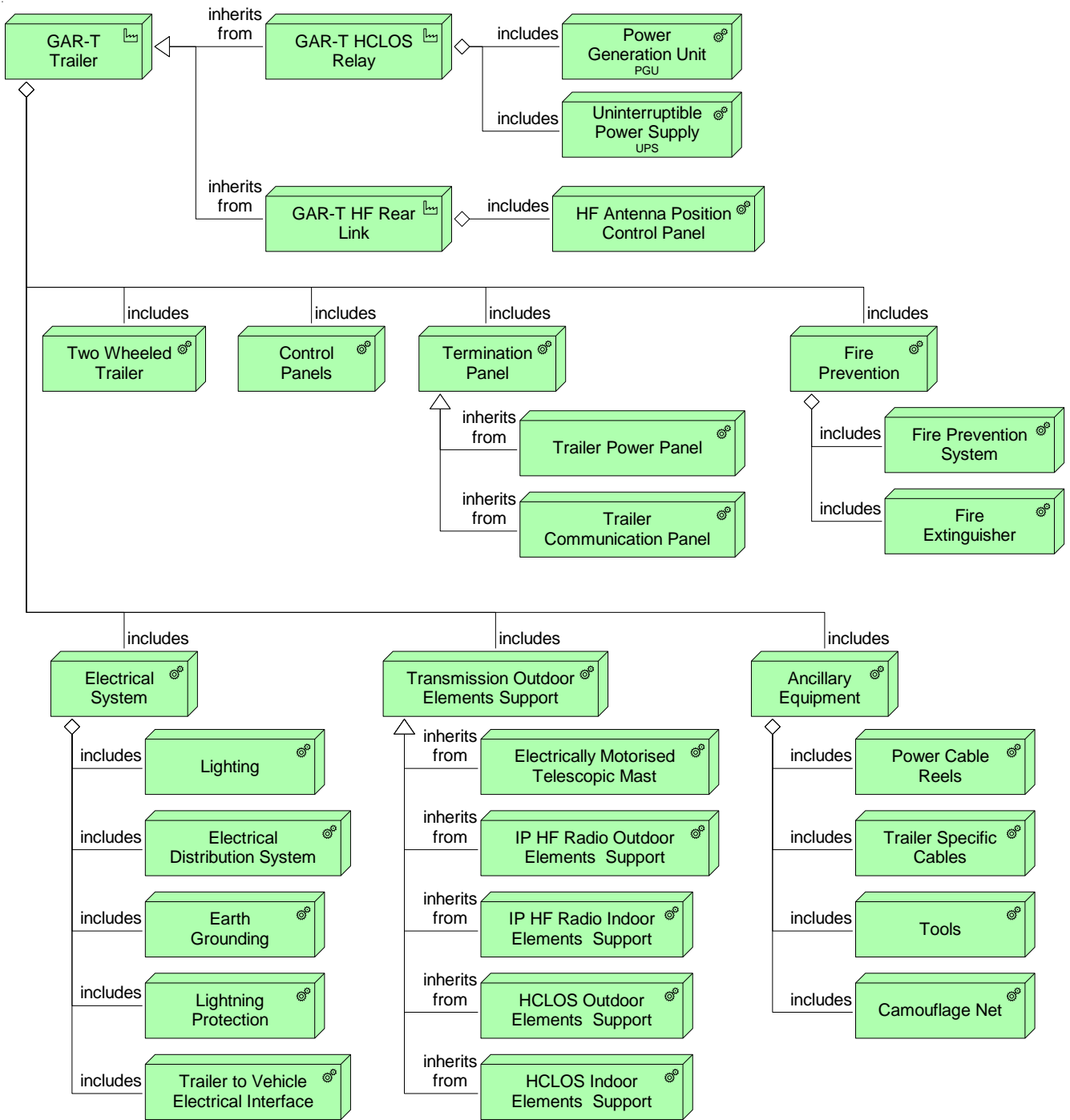

Figure 89 - GAR-T Trailer Breakdown Structure

**SRS** (PRTTDCIS-2266)

~~SRS-1358~~ The GAR-T Trailer shall support;

- Electrical power generation and/or distribution; and,
- ONE (01) electrically motorized telescopic mast and associated equipment; and,
- Electrical command and control interface for the operation of all the electrical equipment (e.g. generator, masts, etc.); and,
- Ancillary equipment; and,
- Mast stabilization fixtures and accessories (e.g. guy wires, pickets, etc.).

**7.4.1.2 Mechanical****SRS** (PRTTDCIS-2267)

~~SRS-1359~~ The GAR-T shall be assembled on a single two wheeled trailer.

**SRS** (PRTTDCIS-2268)

~~SRS-1360~~ The maximum weight of the trailer including all installed equipment shall not exceed 2000kg.

**SRS** (PRTTDCIS-2422)

~~SRS-1361~~ The Trailer overall dimensions, weight, and axle loading shall comply with the European Traffic Regulation

**SRS** (PRTTDCIS-2269)

~~SRS-1362~~ The GAR-T maximum dimensions shall not exceed following values:

- maximum Total Length: 4200mm; and,
- maximum Total Width: 2200mm; and,
- maximum Height: 2100mm.

**SRS** (PRTTDCIS-2270)

~~SRS-1363~~ The GAR-T shall be suitable for on-road and off-road traffic when towed by a range of tactical vehicles.

**SRS** (PRTTDCIS-2272)

~~SRS-1364~~ The towed Trailer shall be meet following speed limits

- Road speed:  $\geq 90$  km/h; and,
- All terrain speed:  $\geq 30$  km/h.

**SRS** (PRTTDCIS-2273)

~~SRS-1365~~ The Trailer shall include four mechanically operated stabilization retractable legs (two at the rear and two at the front) equipped with "bulls-eye" level systems.

**SRS** (PRTTDCIS-2537)

~~SRS-1366~~ The trailer stabilization legs shall be designed to ensure sufficient stability to the trailer when its payload (Power Generator, Antenna, etc.) are operating or being maintained while the trailer is disconnected from the vehicle.

**SRS** (PRTTDCIS-2274)

~~SRS-1367~~ The maximum installation ground slope for trailer payload operation shall be considered to be 20 degrees in any direction.

**SRS** (PRTTDCIS-2423)

~~SRS-1368~~ The Trailer Towing Eye shall be compliant with STANAG 4101.

**SRS** (PRTTDCIS-2514)

~~SRS-1369~~ The Towing Eye shall allow the maximum possible articulation between tractor and trailer in compliance with STANAG 4101 and DIN74050.

**SRS** (PRTTDCIS-2421)

~~SRS-1370~~ The Trailer shall comply with following limits

- Exit angle:  $\geq 27$  degree; and,
- Turning angle:  $\geq 80$  degree; and,
- Wading:  $\geq 760$  mm.

**SRS** (PRTTDCIS-2424)

~~SRS-1371~~ The height above the ground level of the Trailer towing eye (trailer towing bar) shall be adjustable between 45 cm and 105 cm.

**SRS** (PRTTDCIS-2526)

~~SRS-1372~~ The jockey wheel height shall be continuously adjustable when in vertical position.

**SRS** (PRTTDCIS-2428)

~~SRS-1373~~ The Trailer braking systems shall be built in accordance with EEC Regulation (EC) No 661/2009 of the European Parliament and of the Council of 13 July 2009.

**SRS** (PRTTDCIS-2429)

~~SRS-1374~~ The Trailer braking system shall include Anti-lock Braking System (ABS) connections.

**SRS** (PRTTDCIS-2430)

~~SRS-1375~~ The trailer shall be equipped with an efficient hydraulic or compressed air braking system on all wheels and a mechanical hand-brake able to keep the fully loaded trailer in standing position on an incline of minimum 30 degrees.

**SRS** (PRTTDCIS-2431)

~~SRS-1376~~ The trailer shall be equipped with tie down hooks/lugs for anchoring the equipment inside aircraft or on other transportation means during transit as well as with a set of lashing material that assure safe and secure tie down.

**SRS** (PRTTDCIS-3179)

~~SRS-1377~~ The lashing straps with buckle shall be in accordance with the European Standard for lashing: EN-12195 series.

**SRS** (PRTTDCIS-2524)

~~SRS-1378~~ The trailer shall be equipped with reinforced metallic mudguards and pneumatic tires designed for use on motorway as well as off-road (rough terrain).

**SRS** (PRTTDCIS-2432)

~~SRS-1379~~ The Trailer tires shall be Multi-Purpose Tires (MPT) steel belted radial military.

**SRS** (PRTTDCIS-2507)

~~SRS-1380~~ The tires shall be "Run Flat" type, tread with mud and snow profile mounted on heavy duty type wheels.

**SRS** (PRTTDCIS-2506)

~~SRS-1381~~ The overall trailer dimensions, weight, and axle loading shall be in accordance with the European Traffic Regulation.

**SRS** (PRTTDCIS-2433)

~~SRS-1382~~ A spare wheel, with spare tire mounted on it, shall be installed on each trailer.

**SRS** (PRTTDCIS-2439)

~~SRS-1383~~ The trailer shall be equipped with a retractable jockey wheel, which shall be very rigidly and safely fixed to the towing attachment.

**SRS** (PRTTDCIS-2440)

~~SRS-1384~~ The jockey wheel height shall be continuously adjustable when in vertical position;

**SRS** (PRTTDCIS-2441)

~~SRS-1385~~ Any trailer fixed side boards, and droppable and removable tailgate shall be equipped with restraining chains

**SRS** (PRTTDCIS-2442)

~~SRS-1386~~ The Trailer shall include adequate draining holes.

**SRS** (PRTTDCIS-2443)

~~SRS-1387~~ The Trailer ground clearance shall not be less than 300mm.

**SRS** (PRTTDCIS-2504)

~~SRS-1388~~ Prior to delivery to and acceptance by the Purchaser, the Contractor shall adjust and service each trailer for immediate operational use, including at least the following:

- adjusting braking system; and,
- checking electrical system; and,
- inflating all tires; and,
- completely lubricating all running gear with grades of lubricants specified by the Contractor for the ambient temperature at the delivery point.

**SRS** (PRTTDCIS-2525)

~~SRS-1389~~ The tires (including the spare tire) shall comply with Regulation (EC) No 661/2009 of the European Parliament and of the Council of 13 July 2009.

**SRS** (PRTTDCIS-2509)

~~SRS-1390~~ Sufficient space around the wheels shall be foreseen to allow the safe operation of the trailer with tire chains.

**SRS** (PRTTDCIS-2508)

~~SRS-1391~~ The spare wheel shall be easily accessible for dismounting and re-mounting by maximum TWO (02) staff.

**SRS** (PRTTDCIS-2511)

~~SRS-1392~~ The trailer shall be fabricated from aluminium or steel, or stainless steel, or austenitic stainless steel.

**SRS** (PRTTDCIS-2512)

~~SRS-1393~~ The trailer deck assembly shall have an “anti-slip” finish to support the presence and movement of personnel.

**SRS** (PRTTDCIS-2515)

~~SRS-1394~~ The trailer shall be equipped with a retractable jockey wheel, which shall be very rigidly fixed to the towing attachment.

**SRS** (PRTTDCIS-2516)

~~SRS-1395~~ The trailer shall be equipped with minimum FOUR (04) lifting eyes for lifting with a crane and for helicopter under slung transportation.

**SRS** (PRTTDCIS-2517)

~~SRS-1396~~ The Contractor shall ensure that the fully equipped trailer weight is evenly distributed.

**SRS** (PRTTDCIS-2527)

~~SRS-1397~~ The longitudinal weight distribution shall be such that the trailer is easily maneuverable and stable on all kinds of ground.

**SRS** (PRTTDCIS-2528)

~~SRS-1398~~ The fully loaded configuration of the trailer shall have the center of gravity marked with matt black color paint on its structure

**SRS** (PRTTDCIS-2518)

~~SRS-1399~~ The trailer shall include operation plates and designation plates imprinted on photosensitive anodized aluminium, conforming to type H, MIL-DTL 15024F, with a matt black background.

**SRS** (PRTTDCIS-2530)

~~SRS-1400~~ Plates shall be located in convenient position without creating confusion with each other.

**SRS** (PRTTDCIS-2531)

~~SRS-1401~~ Plates shall include as the minimum:

- operation instructions; and,
- servicing instruction; and,
- precautionary instructions to avoid personnel injury or equipment damage (red background); and,
- emergency procedures; and,
- hydraulic schemes; and,
- characteristics; and,
- identification; and,
- serial numbers,

**SRS** (PRTTDCIS-2519)

~~SRS-1402~~ The trailer shall give sufficient load on the towing hook to ensure a good road holding.

**SRS** (PRTTDCIS-2532)

~~SRS-1403~~ The trailer shall be equipped with two handles at the rear and two handles at the towing attachment to facilitate movement by hand.

**SRS** (PRTTDCIS-2522)

~~SRS-1404~~ The trailer suspension shall be independent progressive with a telescopic shock absorber per wheel.

### 7.4.1.3 Electrical

#### SRS (PRTTDCIS-2271)

~~SRS-1405~~ The GAR-T trailer electric system shall be 24VDC.

#### SRS (PRTTDCIS-2284)

~~SRS-1406~~ The GAR-T shall include an electrical management system for the operation of the electrical equipment, electrical protection systems and exterior interfaces.

#### SRS (PRTTDCIS-2285)

~~SRS-1407~~ The GAR-T electrical management system shall be housed in an environmentally proof cabinet with a lockable door.

#### SRS (PRTTDCIS-2544)

~~SRS-1408~~ The GAR-T electrical management cabinet shall contain LED-based illumination light source with following modes:

- Turned OFF; and,
- White Light; and,
- Combat Lights.

#### SRS (PRTTDCIS-2545)

~~SRS-1409~~ The GAR-T electrical management cabinet illumination light source in combat mode shall meet following characteristics:

- 625nm to 650nm wavelength; and,
- Connected to a control panel that allows combat mode On/Off which; and,
- Shall be automatically engaged and bypass White light mode when respective door is open; and,
- Powered from UPS with autonomy of at least 30 minutes; and,
- Equipped with a test button.



**SRS** (PRTTDCIS-2286)

~~SRS-1410~~ The GAR-T electrical management system shall include:

- Operational indicators - green colour; and,
- Malfunction indicators - red colour; and,
- Electrical protection for equipment and operator; and,
- Mast controller system; and,
- One external power input; and,
- One external power output; and,
- An Emergency stop push-button that meets the following:
  - A Red Mushroom type push button; and,
  - Protected to prevent inadvertent operation; and,
  - With an activation that shall be possible without opening any panels, flaps, doors or any other type of covers with easy access and no obstructions; and,
  - Conforms to the following directives and standards: MD 2006/42/EC, LVD 2014/35/EU, IEC 60947-5-1:2016, IEC 60204-1:2016, ISO 13849-1:2015, IEC 60947-5-5:1997 +AMD1:2005+AMD2:2016 CSV.

**SRS** (PRTTDCIS-2287)

~~SRS-1411~~ The GAR-T electrical sockets shall be as follows;

- External input electrical socket: Mennekes INB.WCD 32A 2P+Earth 230VAC IP67 SCHUKO TM or equivalent, in colour RAL 840R 6014, non-gloss or equivalent; and,
- External output electrical socket: Mennekes INB. Contact Box 16A 3P 6H 230VAC IP67 TM or equivalent, in colour RAL 840R 6014, non-gloss or equivalent.

**SRS** (PRTTDCIS-2425)

~~SRS-1412~~ The trailer electrical connectors for connection to a towing vehicle shall meet requirements stipulated in STANAG 4007 edition 2.

**SRS** (PRTTDCIS-2523)

~~SRS-1413~~ The lighting on the trailer shall consist of:

- normal service lighting and reflectors in accordance with Regulation (EC) No 661/2009 of the European Parliament and of the Council – Lighting and Light-signaling Devices; and,
- blackout and convoy lighting in accordance with the requirements of the latest issue of STANAG 4381.

**SRS** (PRTTDCIS-2534)

~~SRS-1414~~ The trailer shall include a 12-core type connection cable to connect the trailer to the Vehicle.

**SRS** (PRTTDCIS-2535)

~~SRS-1415~~ The length of the connection cable shall be such as to extend at least 500 mm beyond the towing eye.

**SRS** (PRTTDCIS-2536)

~~SRS-1416~~ The cable connection plug shall be equipped with a spring-loaded metallic protective cap.

**SRS** (PRTTDCIS-2533)

~~SRS-1417~~ The Trailer shall be equipped with a junction box fixed to the trailer chassis and terminated by a NATO 12-pin receptacle (socket) in accordance with STANAG 4007 edition 2.

#### 7.4.1.4 Ancillary Equipment

**SRS** (PRTTDCIS-1427)

~~SRS-1418~~ The GAR-T shall include the following ancillary equipment;

- ONE (01) 6 kg dry chemical power dry powder fire extinguishers Class ABC and suitable for fires involving electronic equipment up to 1000 V mounted in such a manner that it is easily accessible from the ground; and,
- TWO (02) high intensity LED cold white light directional spotlights; and,
- ONE (01) aluminium box to store equipment and accessories (e.g. cable reels, stakes, etc.), with dimensions appropriated to the available space on GAR-T; and,
- Earthing stakes in adequate size and quantities to assure effective and safe earthing, "T" shape, with threaded cone end and mechanic couplings to connect to the copper braid earthing straps; and,
- Copper braid earthing straps in adequate size and quantities to assure effective and safe earthing of at least 10 meters in length each; and,
- TWO (02) metal wheel-arresting wedges; and,
- TWO (02) snow chains; and,
- A storage box including wheel changing tools (a tire jack, lug wrench, and strong-arm bar). The box shall be designed to restrict the entry of water and the tools shall be secured in place; and,
- Aluminium plate or plates (as required) with black background with following information printed:
  - Operating instructions, emergency procedures, electrical schematics, technical characteristics, nomenclature and serial number;
  - Center of gravity marking in yellow in accordance with the colour standard mat paint RAL 1007; and,
  - Information pertaining to air (as internal cargo-load and as helicopter external load), land, maritime and railways transportation.

**SRS** (PRTTDCIS-3180)

**SRS-1419** The fire extinguisher shall meet requirements as stipulated in following standards:

- EN 3-7:2004+A1:2007 Portable fire extinguishers. Characteristics, performance requirements and test methods; and,
- EN 3-8:2006 Portable fire extinguishers. Additional requirements to EN 3-7 for the construction, resistance to pressure and mechanical tests for extinguishers with a maximum allowable pressure equal to or lower than 30 bar; and,
- EN 3-10:2009 Portable fire extinguishers. Provisions for evaluating the conformity of a portable fire extinguisher to EN 3-7.

**SRS** (PRTTDCIS-2436)

**SRS-1420** The Trailer shall be delivered with a camouflage net stored on the trailer.

**SRS** (PRTTDCIS-3046)

**SRS-1421** As a set together with Vehicle Camouflage Net, the nets shall cover the entire trailer and its associated Shelters, and disguise its shapes.

**SRS** (PRTTDCIS-3048)

**SRS-1422** The net shall be composed of disruptive patterning for the European Theatre of Operations (woodland).

**SRS** (PRTTDCIS-3184)

**SRS-1423** Camouflage net shall be in compliance with Allied Engineering Publication AEP-31e(1) Reference Document of Colors for Disruptive Camouflage for Military Equipment In Use In NATO.

**SRS** (PRTTDCIS-3185)

**SRS-1424** Camouflage net materials shall be resistant to mould growth and shall withstand limited contamination by the most relevant fungal species listed in Table 1 of AECTP 300 Edition D, version 1, test method 308 without substantial degradation. The mould growth shall manifest as no greater than 'Trace' when tested in accordance with method 308.

**SRS** (PRTTDCIS-3186)

**SRS-1425** Camouflage net water absorption shall not exceed 10%~~shall be 100% waterproof~~ and shall will not become logged or heavy due to wet or damp conditions.

**SRS** (PRTTDCIS-3187)

**SRS-1426** Camouflage net shall be UV deterioration and infra-red treated, of a non-toxic fabric, but lightweight, strong and durable.

**SRS** (PRTTDCIS-3188)

~~SRS-1427~~ Camouflage net shall resemble normal foliage in natural conditions and blend into the natural surroundings while being as quiet and rustle free as possible.

**SRS** (PRTTDCIS-3189)

~~SRS-1428~~ Camouflage net shall be specially coated to reduce shine and glare.

**SRS** (PRTTDCIS-3190)

~~SRS-1429~~ Camouflage net shall remain pliable in the extreme environmental conditions the associated housing element is to be compliant with.

**SRS** (PRTTDCIS-3191)

~~SRS-1430~~ Special flame retardant treatments shall have been applied to Camouflage net.

**SRS** (PRTTDCIS-3192)

~~SRS-1431~~ Camouflage net shall be easily compressed and packed into a storage bag for ease of transportation and storage.

**NOTE** (PRTTDCIS-3193)

~~[224]~~ The use of lightweight modern waterproof textiles is recommended.

**SRS** (PRTTDCIS-3194)

~~SRS-1432~~ Camouflage net storage bag shall be sized to allow repacking under field conditions.

**SRS** (PRTTDCIS-3195)

~~SRS-1433~~ Camouflage net shall be provided with all the necessary associated equipment in order to set-up the nets over the housing element and to anchor it. This might include, but is not limited to strings, spikes, arch and bars. All shall be stored with the nets.

**SRS** (PRTTDCIS-3198)

~~SRS-1434~~ TDCIS shall continue to meet all requirements (functional, technical, performance, operational, safety, environmental endurance, etc.) while the camouflage nets are fitted on the trailers and on other pieces of equipment.

**SRS** (PRTTDCIS-3199)

~~SRS-1435~~ The design of the trailer shall include any device to allow the camouflage net fitting.

**SRS** (PRTTDCIS-3200)

~~SRS-1436~~ The design of the trailer shall provide space for storage of the camouflage net.

**SRS** (PRTTDCIS-3201)

~~SRS-1437~~ The design of the trailer shall ensure TDCIS operation and safety shall not be affected by the camouflage net.

**SRS** (PRTTDCIS-2437)

~~SRS-1438~~ The Trailer shall be delivered with a maintenance road kit including all necessary tools and spares.

**SRS** (PRTTDCIS-2438)

~~SRS-1439~~ The Trailer maintenance road kit shall be stored on the trailer.

**SRS** (PRTTDCIS-2444)

~~SRS-1440~~ The Trailer shall include two metal wheel arresting wedges.

#### 7.4.1.5 Telescopic Mast

**SRS** (PRTTDCIS-2291)

~~SRS-1441~~ The GAR-T shall support ONE (01) electrically operated telescopic antenna mast to support either a Beyond Line of Sight (BLOS) HF Rotating Log-periodic Antenna or two HCLOS radio systems.

**SRS** (PRTTDCIS-2292)

~~SRS-1442~~ The GAR-T mast dimensions shall be measured from the ground and be:

- Height when fully retracted shall fit within the GAR-T foot print; and,
- Height when fully extended;  $\geq 10.5$  m.

**SRS** (PRTTDCIS-2293)

~~SRS-1443~~ It shall be possible to raise and lower the GAR-T motorised telescopic mast with all equipment installed (antennas, rotors, radios adapters, cables, etc.).

**SRS** (PRTTDCIS-2294)

~~SRS-1444~~ The GAR-T motorised telescopic mast shall be raised and lowered when powered by the main electrical power supply (external or generator) or when powered by the UPS (i.e. Shelter UPS or Trailer UPS for the HCLOS relay variant).

**SRS** (PRTTDCIS-2295)

~~SRS-1445~~ Operation of the GAR-T motorised telescopic mast shall be possible through the use of a remote control system.

**SRS** (PRTTDCIS-2296)

~~SRS-1446~~ It shall be possible to raise and lower the GAR-T motorised telescopic mast manually (i.e. in case of total power failure) by a single System Administrator within 600 seconds.

**SRS** (PRTTDCIS-2538)

~~SRS-1447~~ The Contractor shall include supplementary wind tie-downs in the trailer design to cater for the Climatic and Geographical Conditions GAR-T variants are to operate.

**SRS** (PRTTDCIS-2539)

~~SRS-1448~~ The wind tie-downs shall be securely stored within each trailer to be deployed on set up.

**SRS** (PRTTDCIS-2543)

~~SRS-1449~~ When designing the wind tie-downs, the Contractor shall keep the quantities of ground anchor points to the strict minimum necessary.

**SRS** (PRTTDCIS-2540)

~~SRS-1450~~ When designing the wind tie-downs, the Contractor shall consider the trailer disconnected from any vehicle, with fully extended telescopic antenna mast and antenna mounted on it (whichever variant poses greater load when combined with wind load) in its worst-case scenario.

## 7.4.2 GAR-T HF Rear Link Variant

**NOTE** (PRTTDCIS-2283)

~~[222]~~ The GAR-T HF Rear Link variant electrical power will be provided by the power generator system of the associated Rear Link shelter.

**SRS** (PRTTDCIS-2290)

~~SRS-1451~~ The GAR-T HF Rear Link variant shall include an antenna positioner control panel.

**SRS** (PRTTDCIS-2298)

~~SRS-1452~~ The GAR-T HF Rear Link telescopic mast shall support one Log-Periodic HF antenna and its positioner for angular orientation.

**SRS** (PRTTDCIS-2300)

**SRS-1453** In addition to those specific in the GAR-T Common Base, the HF Rear Link variant shall include compartments to accommodate the following;

- One Log-Periodic HF antenna system (Positioner and Antenna); and,
- One reel containing a 100m RF coaxial cable terminated with N-type male plug, adequate for the RF signal between the shelter and the ATU; and,
- One reel containing a 100m power cable adequate for the GAR-T Rear Link Variant power rating.

### 7.4.3 GAR-T HCLOS Relay Variant

**SRS** (PRTTDCIS-2288)

**SRS-1454** In addition to the GAR-T common base, the HCLOS Relay variant electric management system shall also include:

- Power generator supervisory and control system; and,
- Measurement instruments (volt meters, amp meters, frequency meter).

**SRS** (PRTTDCIS-2289)

**SRS-1455** The GAR-T HCLOS relay variant electrical command and control panel shall support provisions (e.g. cover) to “blackout” the command and control system indicators.

**SRS** (PRTTDCIS-2275)

**SRS-1456** The GAR-T HCLOS relay variant shall include a PGU.

**SRS** (PRTTDCIS-2278)

**SRS-1457** The GAR-T HCLOS relay variant power generator unit shall include:

- Digital command panel; and,
- Battery charger; and,
- Starter protection; and,
- Electronic voltage stabilization.

**SRS** (PRTTDCIS-2279)

**SRS-1458** The GAR-T HCLOS relay variant electrical generator system noise level (dB) shall be  $\leq$  55/65/70 at distance (m) of 7/5/3 respectively.

**SRS** (PRTTDCIS-2445)

**SRS-1459** Jerry Cans to refuel the power generator shall be included and stored on the Trailer.

**SRS** (PRTTDCIS-2447)

**SRS-1460** The Trailer shall include enough Jerry Cans to perform TWO (02) PGU full Fuel tank refill.

**SRS** (PRTTDCIS-2280)

~~SRS-1461~~ The GAR-T HCLOS relay variant shall include a UPS battery system.

**SRS** (PRTTDCIS-2281)

~~SRS-1462~~ The GAR-T HCLOS relay variant UPS battery system shall be charged by the power generator or the external power input.

**SRS** (PRTTDCIS-4679)

~~SRS-1463~~ In addition to those specific in the GAR-T Common Base, the HCLOS variant shall include compartments to accommodate the following;

- TWO (02) HCLOS systems and ancillaries; and,
- Cable reels necessary to connect HCLOS Systems to any Node.

## 7.5 Cases

### 7.5.1 General

**NOTE** (PRTTDCIS-4470)

[223] Cases specialization in different variants is illustrated on following diagram.

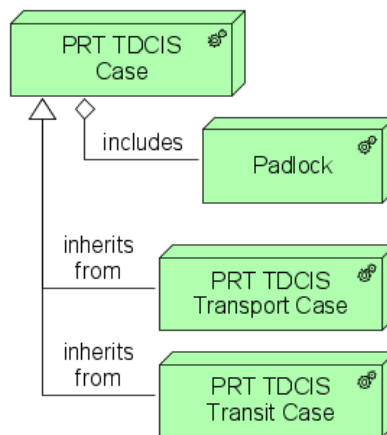

Figure 90 - Cases specialization into variants



**SRS (PRTTDCIS-4471)**

**SRS-1464** Cases containing their housed elements, fully assembled and enclosed ready for transport, shall not exceed the external sizes and weights as specified in following table, including lids.

Case Type	Maximum Width x Height x Depth	Maximum Weight
TINY	35 x 15 x 35cm	10 kg
HANDCARRY	58 x 27 x 45cm	20 kg

Table 42 - Transit cases maximum size and weights

**SRS (PRTTDCIS-4472)**

**SRS-1465** Each Case shall be equipped with:

- 1) Heavy duty, drop lifting handles with return spring and plastic or rubber sheathing with a minimum of four for cases heavier than 40 kg.; and,
- 2) Auto pressure release valves, and humidity indicators; and,
- 3) A re-settable and re-usable device to detect shocks and tilt, including the direction and angle of impact; and,
- 4) Stacking corners; and,
- 5) Removable or retractable casters to allow easy handling; and,
- 6) Fittings to assure that each case is lockable to prevent theft or tampering (i.e. padlocks).

**SRS (PRTTDCIS-4473)**

**SRS-1466** Each Case shall be delivered with a padlock that meets following requirements:

- 1) Body made from hardened steel; and,
- 2) Inner components made from non-corrosive materials; and,
- 3) Hardened boron steel shackle with minimum 8mm diameter; and,
- 4) 05 (FIVE) digits code locking mechanism; and,
- 5) Suitable for outdoor use, weatherproof; and,
- 6) Tested against impact, drilling, cutting, lever – test certificate /CoC issued by the supplier shall be provided; and,
- 7) Minimum GRADE 3 – Medium / High Security: according to Central European Norm (CEN Grade) or EN 12320:2012 Building hardware. Padlocks and padlock fittings. Requirements and test methods.

**SRS (PRTTDCIS-4474)**

**SRS-1467** Once active components in Cases are configured for a given security classification, their affiliation to the security domain shall be visually identifiable through the use of removable tags mentioning the Security domain and using Colour scheme in line with security domain color scheme. These tags shall be firmly attached to the surface of the cases, to avoid accidental removal.

**NOTE** (PRTTDCIS-4475)

[224] Upon removal of the configuration data, and sanitation of non-volatile storage from the active elements, the security domain tags will be removed.

**SRS** (PRTTDCIS-4476)

~~SRS-1468~~ Cases, when fully loaded, shall allow stacking them on top of each other with no damage to housed equipment and the cases itself.

**SRS** (PRTTDCIS-4477)

~~SRS-1469~~ Case stacks shall be secured through the use of interlocks or equivalent mechanisms.

**SRS** (PRTTDCIS-4478)

~~SRS-1470~~ Pressure release valves shall avoid also soaking water into the case. This can occur for example (but not only) due to the negative pressure when a case is rapidly cooled down during rain after being exposed long to the sun.

**SRS** (PRTTDCIS-4479)

~~SRS-1471~~ Cases shall be protected against ingress of particles and liquids at IP65 or higher.

**SRS** (PRTTDCIS-4480)

~~SRS-1472~~ Cases shall be stackable on Standard Euro Pallets (EUR 1, 1,200 by 800 by 144 millimeters) not exceeding these dimensions.

**SRS** (PRTTDCIS-4481)

~~SRS-1473~~ Transit Cases shall be able to be loaded and secured on HCU 463L Air Cargo Pallet (HCU-6/E), that is compliant with MIL-STD-1791C w/Change 1 - 29 December 2017: Designing for Internal Aerial Delivery in Fixed Wing Aircraft (certified for these aircrafts: C-130, C-5, C-27, CH-47, KC-10, C-17, C-9).

**SRS** (PRTTDCIS-4482)

~~SRS-1474~~ Cases packed for transport shall be capable of being transported via road, rail, sea, and air transport.

**SRS** (PRTTDCIS-4483)

~~SRS-1475~~ Cases shall be capable of being secured to anchor points to prevent theft and movement during transportation.

**SRS** (PRTTDCIS-4484)

~~SRS-1476~~ For Road Transport, Cases shall support all roads (motorway, unpaved road and country road) without sustaining any damage (for example due to shock or vibrations).

**SRS** (PRTTDCIS-4485)

~~SRS-1477~~ For Rail Transport, Cases shall be capable of withstanding, without damage, the shocks and vibrations normally induced by rail transport.

**SRS** (PRTTDCIS-4486)

~~SRS-1478~~ For Air Transport, Cases shall be capable of being loaded into and transported by military transport aircraft.

## 7.5.2 Transport Cases

**NOTE** (PRTTDCIS-4487)

~~[225]~~ Transport Case is the term used to denote those cases carrying equipment not installed in rack chassis frames. Transport Cases contains padding or shock-absorbing material to carry components or user appliances.

**SRS** (PRTTDCIS-4488)

~~SRS-1479~~ Transport cases shall be used to store and transport Elements not integrated in Transit Cases (e.g. End-User Devices (EUD)) and ancillaries.

## 7.5.3 Transit Case

**NOTE** (PRTTDCIS-4489)

~~[226]~~ Transit Case is the term used to denote those cases carrying active CIS equipment (including cryptographic devices) integrated in 19in rack chassis frames. Transit Case components include the shell or housing (e.g. latches, covers, power and signal external terminal boards).

**SRS** (PRTTDCIS-4490)

~~SRS-1480~~ Transit cases shall be used to host, support and protect Elements built in it during storage, transport, operation and handling.

**SRS (PRTTDCIS-4491)**

**SRS-1481** The detailed system design of the Transit Case shall adhere to the subsystems breakdown presented on the following picture:

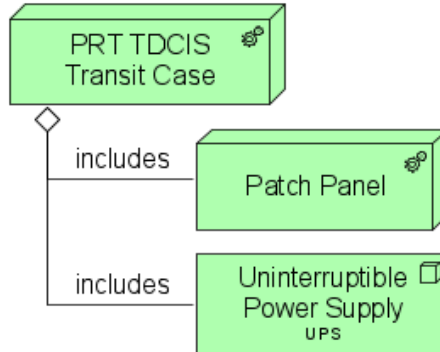

Figure 91 - Transit Case Breakdown

**SRS (PRTTDCIS-4510)**

**SRS-1482** The Transit Case shall implement an Uninterruptible Power Supply (UPS) solution.

**SRS (PRTTDCIS-4511)**

**SRS-1483** All ports (e.g. Copper, Fiber, Console, etc.) from all CIS Elements housed in the transit case shall be remoted to a patch panels.

**SRS (PRTTDCIS-4492)**

**SRS-1484** The complete assembly of components and transit case shall meet the Climatic and Environmental requirements of the CIS module it houses.

**SRS (PRTTDCIS-4493)**

**SRS-1485** The components in a transit case shall be mounted on shock absorbers and vibration dampers, or otherwise hardened, such that the transit case with mounted components as a whole meets the operation, transport, storage and handling conditions specifications.

**SRS (PRTTDCIS-4494)**

**SRS-1486** Where applicable, the racks shall be mounted with sliding bases and retractable cable harness, to allow easy maintenance.

**SRS (PRTTDCIS-4495)**

**SRS-1487** The transit cases shall be of a welded frame construction.

**SRS** (PRTTDCIS-4496)

~~SRS-1488~~ Any removable EMC protection to the CIS Modules transit cases shall count against the maximum weight for the specified transit case and shall be carried for transport within the transit case.

**SRS** (PRTTDCIS-4497)

~~SRS-1489~~ Each transit case, with CIS and/or UPS equipment operating from within the case, shall be provided with adequate air inlets and air outlets to assure required air flow and heat dissipation.

**SRS** (PRTTDCIS-4498)

~~SRS-1490~~ The air inlets and air outlets shall be protected with removable lids for transport and storage

**SRS** (PRTTDCIS-4499)

~~SRS-1491~~ The removable lids shall count against the maximum weight for the specified transit case and shall be carried for transport within the transit case.

**SRS** (PRTTDCIS-4500)

~~SRS-1492~~ Transit Cases shall include patch panels to be used, as a minimum, for any external cable to be connected from or to any Element housed in the Transit Case.

## 8 User Appliances

### 8.1 General

**NOTE** (PRTTDCIS-4395)

[227] This section details the User Appliances (e.g. Workstations, Phones, Printers, etc.).

### 8.2 Semi-Rugged Laptop

**SRS** (PRTTDCIS-1823)

~~SRS-1493~~ Semi-Rugged Laptops shall meet or exceed the following specification:

Attribute	Value
Processor	Intel Core i7
Display	14in LCD, 1920x1080
Memory	16GB DDR4
Optical	DVD optical drive
Keyboard	Portuguese language keyboard layout
Pointing device	Touchpad
Internal Storage	<ul style="list-style-type: none"> <li>ViaSat Eclipt Core 600 SATA SSD 7mm - 128GB (xS laptops)</li> <li>1TB Solid State Disk (BLK, xU and xR laptops)</li> </ul>
Network Adapter	<ul style="list-style-type: none"> <li>100BASE-FX 1300nm multimode (SC) Network Adapted (NS Kit laptops)</li> <li>Integrated 10/100/1000 Gigabit Ethernet Network Adapter (BLK, xU, xR and xS laptops)</li> </ul>
I/O Ports	As a minimum: 2x USB 3.0 port, 1x VGA port, 1x RJ45 Ethernet
Integrated Accessories	Webcam
Power Rating	< 90 W
Environmental constraint	Semi-Rugged

Table 43 - Semi-Rugged Laptop specification

**SRS** (PRTTDCIS-4736)

Each Viasat Eclipt Core 600 SATA SSD shall be delivered with TWO (02) Keystone Tokens.

### 8.3 VoIP phones

**SRS** (PRTTDCIS-1831)

~~SRS-1494~~ Wired VoIP Phones for the xU, xR and xS security domains shall meet or exceed the features of the Voice End User PFE baseline

**SRS** (PRTTDCIS-1832)

~~SRS-1495~~ Wired VoIP Phones for the xU, xR and xS security domains shall connect to the corresponding UAM over an Eth-Cu interface.

**SRS** (PRTTDCIS-1836)

~~SRS-1496~~ The Wireless VoIP phones for the xU security domain shall meet or exceed the features of the Voice End User PFE baseline for wireless phone.

**SRS** (PRTTDCIS-1837)

~~SRS-1497~~ The wireless IP phones for the xU security domain shall connect to any UAM-xU WiFi Access Point (e.g. Shelter or detachable UAM).

**SRS** (PRTTDCIS-4393)

~~SRS-1498~~ Wired VoIP Phones for the NS Kit shall meet or exceed the features of the Voice End User PFE baseline

**SRS** (PRTTDCIS-4394)

~~SRS-1499~~ Wired VoIP Phones for the NS Kit shall connect to the corresponding UAM over an Eth-FO-SR interface.

**SRS** (PRTTDCIS-1830)

~~SRS-1500~~ VoIP phones shall be delivered with the corresponding user licenses to enable required features for operation with the MMA subsystem of the CNM.

### 8.4 Headset

**SRS** (PRTTDCIS-4734)

The Workstation Headset shall be suitable for Voice Collaboration and VTC Services.